

# Relays and solid-state relays Klippon® Relay

Version 2025



**Weidmüller** 



# Relays and solid-state relays

## Klippon® Relay

### Catalogue 4.2

**Relays and solid-state relays**  
**Klippon® Relay**

Selection guide

Universal range

Application range

**A**

**B**

**C**

**Appendix**

**Service and support**

**Technical appendix/Glossary**

**Index**

Index Type / Index Order No.  
Addresses worldwide

**V**

**W**

**X**

## Switch to simple – with Klippon® Relay

### High-quality relays with unique all-round service

Whether switching, separating, amplifying, or multiplying: relays perform a multitude of different tasks in industrial applications. They have very specific characteristics and are available in almost innumerable varieties on the market.

Klippon® Relay from Weidmüller makes your choice easy. Our worldwide unique all-round offer combines maximum relay variety with matching accessories and first-class service. We provide you with high-quality products that have been thought out down to the smallest detail, combined with comprehensive support from product selection to modern data services. Only with Klippon® Relay can you be sure to get the right relay for your specific needs – and save time and money. That's our promise!





#### Simply selectable

We offer you comprehensive support in choosing the right relay, support you in selecting accessories, and provide tips for installation and maintenance. This saves time and gives you the security of getting the perfect product for each specific application.



#### Simply reliable

Our support enables you to obtain optimally dimensioned relays and solid-state relays for your application within a very short time. This way you can reliably avoid unnecessary machine and system damage and reduce downtimes to a minimum.



#### Simply safe

Klippon® Relay products ensure comprehensive operational safety. Whether large temperature ranges, strong vibrations, fast switching cycles, certain safety requirements, or specific standards and directives: You can get a suitable solution for every environment.



#### Simply maintainable

With Klippon® Relay you can significantly reduce your maintenance effort. Optimum marking options, clear status displays, consistent product labels, connection markings, and much more make your work easier, faster, cheaper, and safer.



#### Simply efficient

Klippon® Relay products are easy, fast, and convenient to install. The PUSH IN technology shortens wiring times. And our fully assembled and tested relay KITS save time during installation and commissioning.



#### Simply profitable

Many products in our Klippon® relay portfolio have multi-voltage inputs, which reduces the width of your stock. Our pre-assembled relay KITS save you even more logistics effort by speeding up material management, storage, and retrieval.

### Switch to solution-oriented – with Klippon® Relay

The application range of our relay modules, power solid-state relays and solid-state relays

Today, custom solutions and components are used in many industrial applications, with the goal of improving system efficiency and productivity. With our application range, we offer you a customised portfolio of relay modules and opto modules that you can use for optimisation in a wide variety of applications. We advise you with our professional expertise, and work with you to develop the best solution for your purpose.



## Solutions for more productivity

### Highly flexible design processes – with Klippon® Relay

For more than 40 years, we have specialised in the optimisation of cabinet infrastructures. Our wide range of relay modules, solid-state relays and additional value-added services combine the highest standards with ultimate quality. Less wiring effort, housing optimisation through space saving, optimal marking and cost reductions – our customers challenges are our motivation.

Our assortment impresses through reliability, longevity and safety. Supplemented by our digital data support, switching load consulting and online selection guides, we support our customers throughout the entire work process – from the planning phase to installation and operation.

In our universal range, you will find an extensive portfolio of relay modules and solid-state relays in various designs.

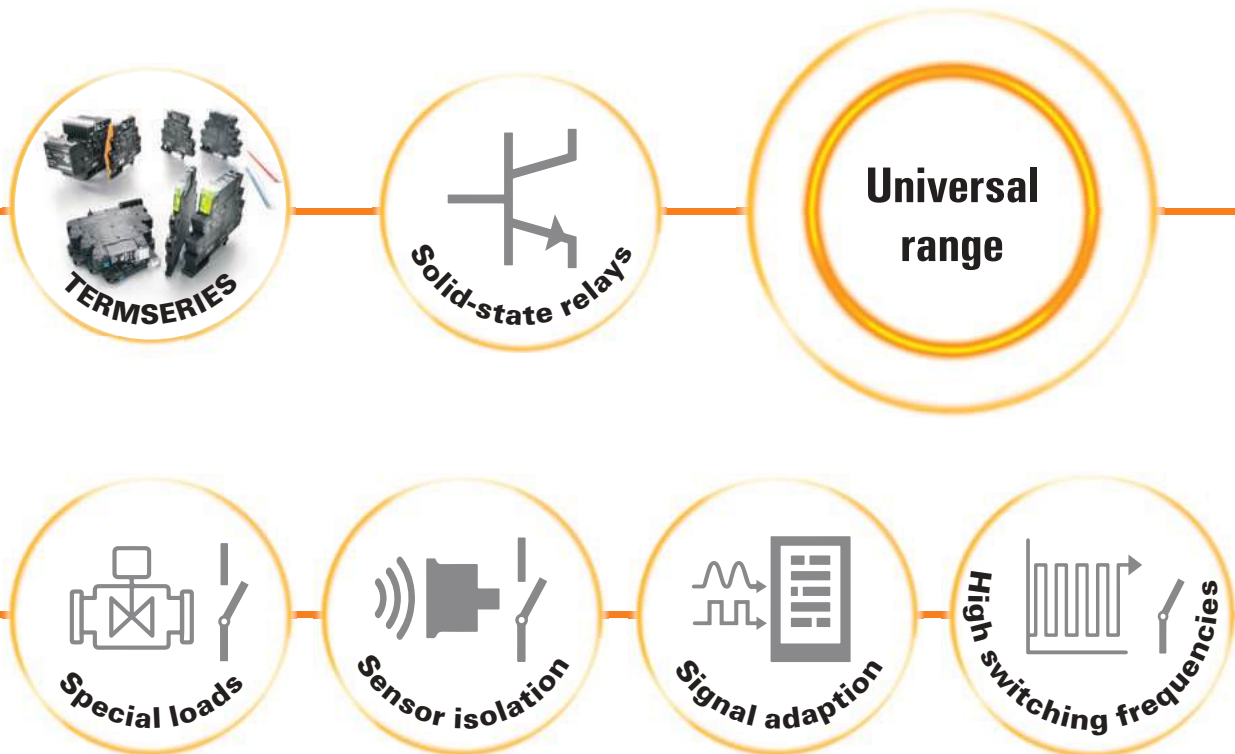

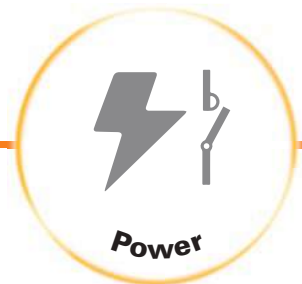
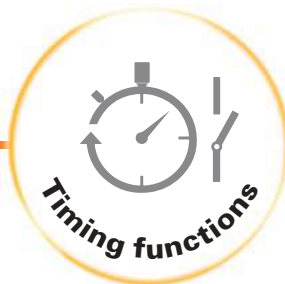
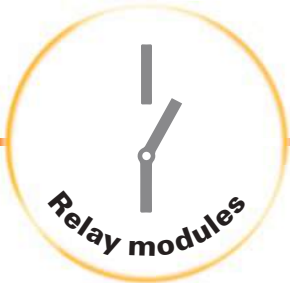

In our application range, you will find a tailor-made portfolio of products to increase your productivity and safety for various fields of application.

Visit our website for more information  
[www.weidmueller.com/klipponrelay](http://www.weidmueller.com/klipponrelay)

# Reliable switching of industrial loads and safe separation and multiplication of signals

## With our high-performance relay modules and solid-state relays

### Universal range

#### Relay modules

For switching and amplifying digital signals in automation technology and for galvanic isolation.

#### TERMSERIES

The all-rounder. Modular relay modules from 6 mm width with extensive accessories, large selection of variants and unlimited cross-connection possibilities.

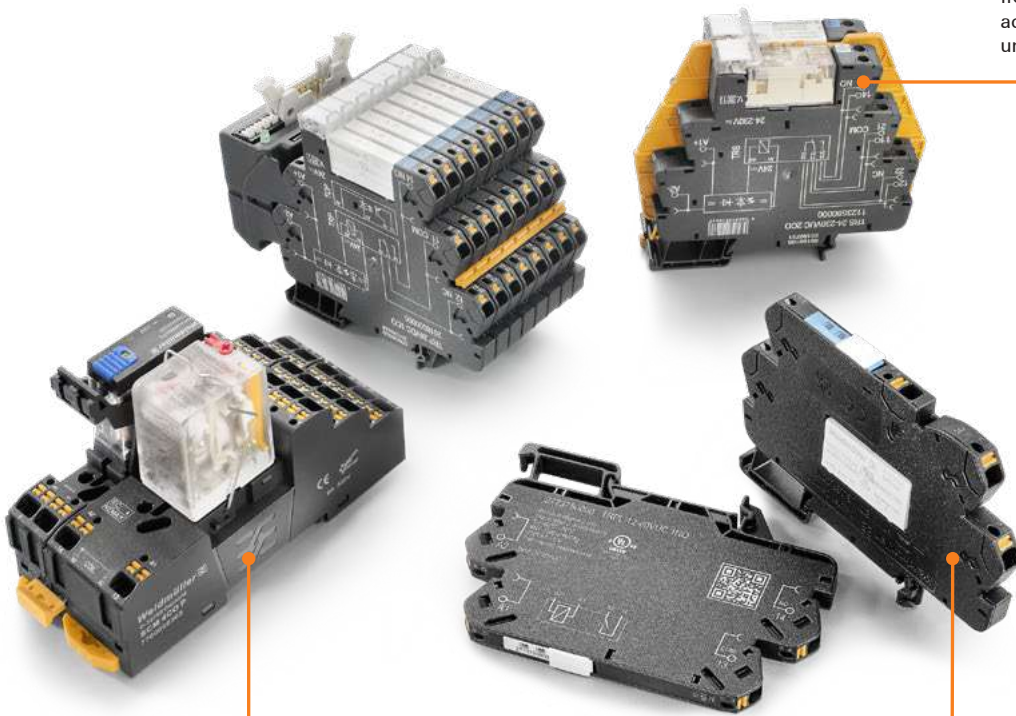

#### D-SERIES

The industrial relay modules with innovative features, an extensive range of variants and a wide assortment of designs for a variety of applications.

#### TERMSERIES-compact

Ultra-compact relay modules from TERMSERIES-compact with soldered relays, the smart all-round choice with a particularly low profile and extensive accessories.



### Solid-state relays

For wear-free switching and amplification of digital signals in automation engineering.

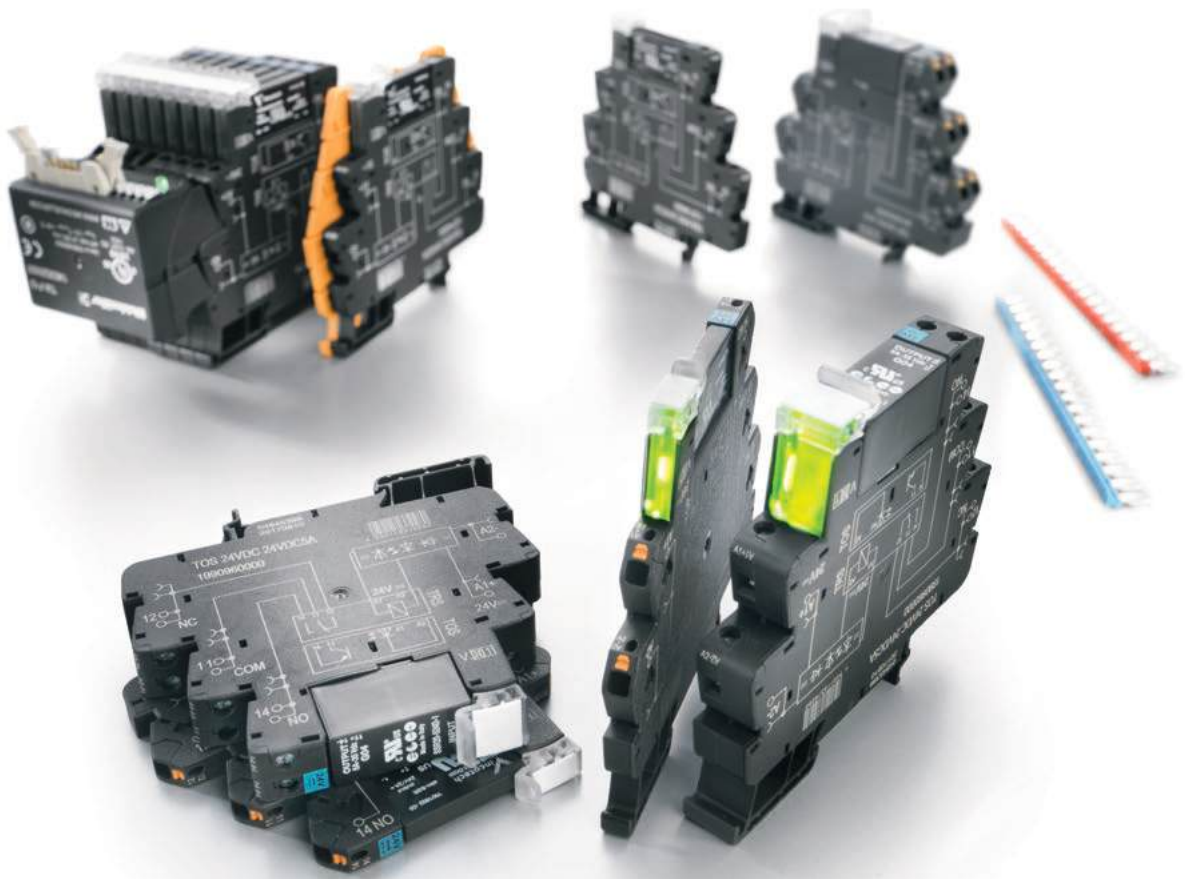

# Reliable switching of industrial loads and safe separation and multiplication of signals

With our high-performance relay modules and solid-state relays

## Application range



### Special loads

Highly durable solid-state relay and relay module for low-wear switching of high inductance levels and inrush currents – reliable, safe, and space-saving.



### Sensor isolation

Space-saving, reliable and fast switching solid-state relay and relay module with gold contacts for isolating sensor signals from the field. Specially designed for reliably switching small loads.



### Signal adaption

Space-saving solid-state relay and relay module for adapting digital signals from external systems to the existing system environment. Cost-efficient use without PLC input cards.



### High switching frequencies

Specially developed solid-state relays and opto modules for reliable and delay-free switching of extremely fast signals up to 550 kHz. Ideally suitable, for example, for high-speed machines.



### Timing functions

Reliable timing relay for delaying, extending or clocking signals, as well as for error compensation at high cycle rates or with short impulses – primarily in system and building automation.



## SIL

### Functional safety

Standardised safety relay for switching signals in safety-relevant systems and processes. Optimal error detection and avoidance to protect personnel and materials.



### Power

Specialised relay for switching high industrial loads. Power-solid-state relay (PSSR) up to 35 A and miniature contactors (PWR) up to 30 A to cover different applications.

# Digital configuration – direct requests

## Efficient engineering with the Weidmüller Configurator

Whether product selection, project planning, automated production or installation: consistently available data models are a cornerstone of digitalised development and production processes. They require standardised product data and interfaces between the interlinked engineering tools as well as integration into the company's IT network.

With the Weidmüller Configurator (WMC) we offer you the ideal basis for efficient product development. Speed up your panel planning by up to 70% and increase your overall productivity. Benefit from extremely high levels of data transparency and availability throughout your entire engineering process.

### Integrated digital planning – quick and easy

#### Provision of intelligent item data

The product data from the Weidmüller Configurator supports you during project planning and can be fully integrated into all common engineering tools. You achieve complete data transparency and availability in all process steps – the basic requirements for Industry 4.0 in panel building.

#### Always the right configuration

The automatic filter function makes it easier to put together suitable relay combinations. Selection errors are corrected automatically, so that only suitable accessories can be included in the configuration. This makes planning easier, saves time and enables complete documentation of the terminal rails.

#### Reliable and simple marking

The Weidmüller Configurator makes continuous marking easier. Thanks to direct interfaces to CAD programs and the M-Print® PRO marking software, you can plan and mark your components in a single step.

#### Quick and easy product requests

Once the components have been put together, you can request them directly from the Weidmüller Configurator – either as individual components or as a pre-assembled complete solution on a terminal rail that can be installed directly on the mounting plate.

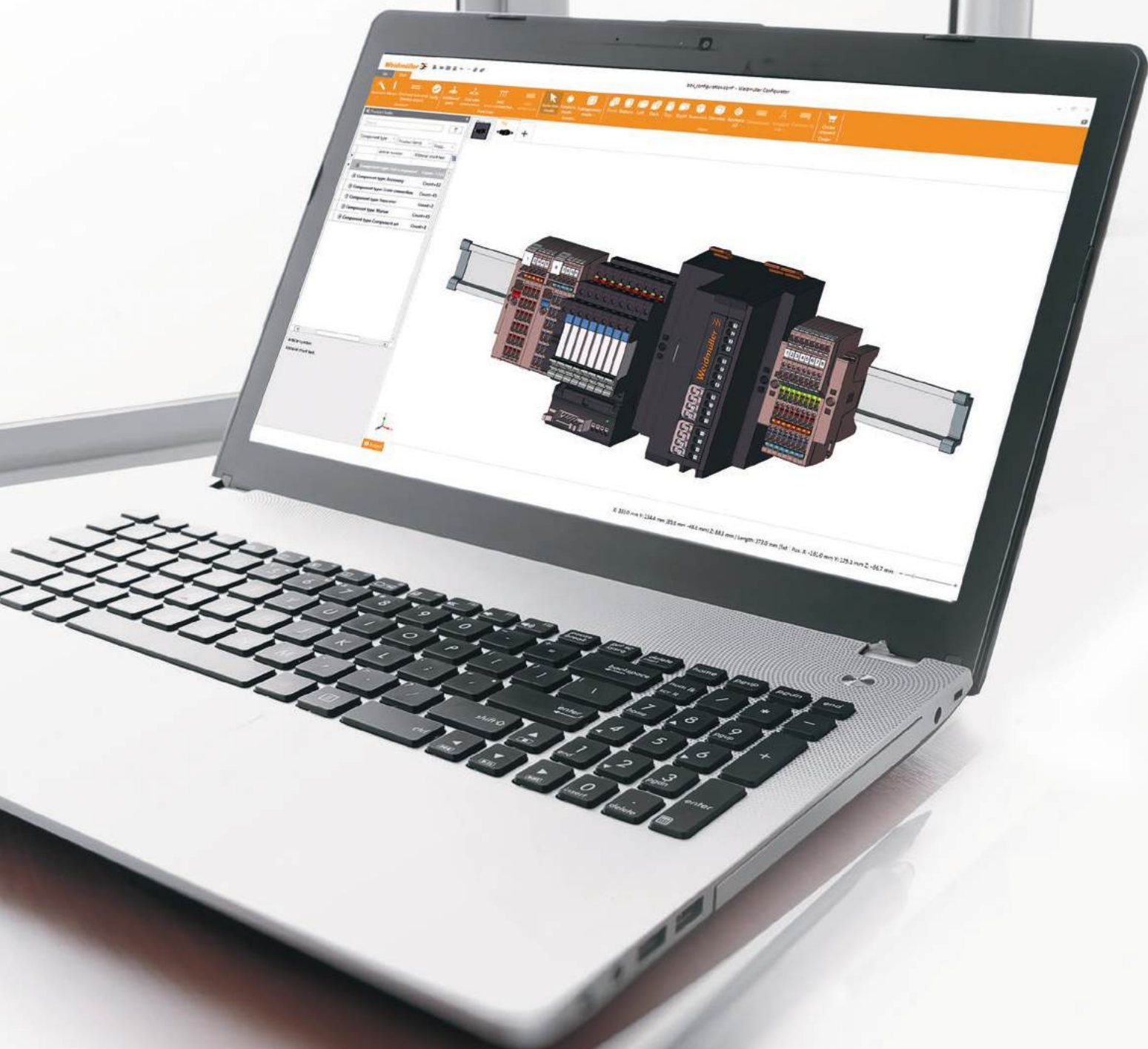

**Get started online now!**

With the Weidmüller Configurator you can make your product development more efficient. Visit our website and take advantage of all the benefits for your engineering and configuration processes free of charge:

**[www.weidmueller.com/wmc](http://www.weidmueller.com/wmc)**



# Selection guide

## Selection guide

Basics for relay module selection	A.2
Selection table for signal relays	A.4
Selection table for power relays	A.6
Simple formulas for calculating individual values	A.8
Information of various contact materials	A.9
Selection criteria for protective circuits of inductive loads	A.10
Relays for LED lamps and devices with high inrush currents	A.12
Relay for forwarding control signals	A.14
Forced guided contacts in detail	A.16
B10(d) + MTTF(d)	A.18

# Find suitable relay modules for your application

## Basics for relay module selection



Electromechanical relays are a varied and cost-effective solution for a wide range of switching processes. They can be used for level and power adaptation and form interfaces between control, signalling and regulating equipment and peripherals. In spite of rising raw material prices, they are still very inexpensive and can be easily integrated into a wide variety of circuit types.

Relay modules from Weidmüller are extremely reliable, durable, and available in many different designs. The diversity of their applications in the various industrial sectors makes it necessary to select a suitable relay for each specific application. The following applies: Due to their design, relay modules are subject to mechanical and electrical wear, which must be taken into account when relay circuits are set up.

EN 60947-4-1 and EN 60947-5-1 describe various industrial reference loads such as resistive, capacitive, and inductive loads that stress the switching contact of a relay modules more or less. Electrical loads are formed out of a mixed load with ohmic, capacitive, and inductive load shares, though in practice, loads with a large inductive load share are used mostly. These include contactors, solenoid valves, motors, etc. We will take a closer look at these areas of application in the following.

### Switching of large AC loads

If large AC loads are switched, the relay can in principal be operated until the specified maximum value of switching voltage, current, or power is reached. However, when switching AC loads, the switching voltage has a much smaller influence on the service life of the relay contact than the switching current. The reason for this is that the arc that occurs when the relay is switched off usually extinguish automatically at the next zero crossing of the load current. In applications with inductive loads, an effective protective circuit should be provided, as otherwise a significantly reduced service life can be expected.



AC3 DC1  
 AC1 DC13  
 AC15 EN 60947

### Switching of large DC loads

Relays can only switch off relatively small direct currents because the zero crossing for extinguishing the arc is missing here. The maximum direct current value is also dependent on the switching voltage as well as on design conditions such as contact gap and contact opening speed. Corresponding current and voltage values are documented in load limit curves.

With undamped inductive DC loads, these values are lower because the energy stored in the inductance can ignite an arc that carries the current through the open contacts. The resulting arc significantly reduces the service life compared to a resistive load.

An effective contact protection circuit can increase the service life of the contacts by 5 to 10 times compared to inductive loads that are not or unfavorably protected. Type 1N4007 freewheeling diodes are preferably suitable for this purpose.

### Switching of utilization categories according to EN 60947

When selecting the relay, the maximum breaking capacity for AC loads and the DC breaking values taken from the load limit curves provide only rough reference values. In practice, however, this is not sufficient because real loads in industrial applications predominantly have inductive or capacitive load shares. Those variables can result in very different values for the service life.

To avoid these disadvantages, the contactor standard EN 60947 divides the loads into different use categories, such as DC-13 or AC-15. The standard is also partly applied to relays. However, users must be aware that these values are only partially suitable for practical use since all DC-13 and AC-15 test loads are highly inductive and operated without a protective circuit.

More precise statements on switching capacity and service life can be given based on specific application data. The more extensive the data collection, the more accurately the service life can be estimated for the respective applications and, if necessary, optimisation suggestions made. For critical applications, the users should determine the service life values themselves.

# Switching of small resistive and inductive loads

## Selection table for signal relays

The table below helps you to select suitable relay modules for the specified loads. A service life of around 100,000 switching operations is assumed.

### TERMSERIES + TERMSERIES-compact



**Suitable KITS are available for all series on this page.**



	1 NO / 1 CO AgNi	RSS 1 CO AgNi	RSS 1 CO AgSnO	RCL 1 CO	RCL 1 NO AgSnO
Example Part No. Single relay 24 V DC input	-	4060120000	1984090000	1984040000	1984080000
Example Part No. KIT 24 V DC input	2773890000	2618000000	2618020000	2618100000	2618090000
Insulation between input and output	reinforced insulation	reinforced insulation	reinforced insulation	reinforced insulation	reinforced insulation
Contact material	AgNi	AgNi	AgSnO	AgNi	AgSnO
Width plugged on socket	6.4 mm	6.4 mm	6.4 mm	12.8 mm	12.8 mm
Socket connection technologies	PUSH IN	PUSH IN and screw	PUSH IN and screw	PUSH IN and screw	PUSH IN and screw
Max. Operating temperature	60 °C	60 °C	60 °C	60 °C	60 °C
Resistive AC load	AC1 loads: Heaters 250 V AC	< 5 A	< 5 A	< 12 A	< 13 A
Inductive AC load	AC15 loads: Valves, contactors 250 V AC	< 1.5 A	< 1.5 A	< 3 A	< 3.5 A
	AC3 loads: 1-phase motors 250 V AC	< 0.5 A	< 0.5 A	< 1 A	< 1.5 A
Resistive DC load	DC1 loads: Heaters 24 V DC	< 3 A	< 3 A	< 8 A	< 9 A
Inductive DC load	DC13 loads: Valves, contactors 24 V DC	< 1 A	< 1 A	< 2 A	< 3 A
Inrush current optimized	-	-	-	-	80 A, 20 ms
Recommended field of application	Miniature switching relay for decoupling PLC's and for switching industrial small loads < 1.5 A in the smallest space.	Miniature switching relay for decoupling PLC's and for switching industrial small loads < 1.5 A in the smallest space.	Miniature switching relay for decoupling PLC's and for switching industrial small loads < 1.7 A in the smallest space.	Miniature industrial relay for decoupling PLC's and switching industrial small loads < 3 A.	Miniature industrial relay with a special contact for switching industrial small loads < 3.5 A with inrush currents up to 80 A / 20 ms. Additional information on page 18.

The indicated currents only apply to the normally open contact. The data of the normally closed contact are to be set at approx. one third of the specified values. The real service life can be both above and below the specified value because each load stresses the switching contact differently and other environmental factors influence the service life of the switching contact, e.g. ambient temperature, mounting position, switching frequency, and many more. Therefore, these values are without guarantee and serve as orientation for better dimensioning. They may not be used as B10 or B10d values for the calculation of failure data such as MTTF or MTTFd either. The assessment of the maximum load capacity was carried out on the basis of many years of practical experience as well as life cycle tests under laboratory conditions.



Digital selection guide for electromechanical relay modules  
[www.weidmuller.com/relayselector](http://www.weidmuller.com/relayselector)

D-SERIES



**RCL 1 NO AgSnO + W**

8866920000
2617930000
reinforced insulation
AgSnO + W
12.8 mm
PUSH IN and screw
60 °C
< 12 A
-
-
< 8 A
-
165 A, 20 ms 800 A, 200 µs

Miniature industrial relay with a special tungsten pre-contact for switching industrial loads with very high inrush currents up to 800 A / 200 µs. Only very conditionally suitable for inductive loads. Additional information on page 19.

**RCL 2 CO**

4058570000
2618400000
reinforced insulation
AgNi
12.8 mm
PUSH IN and screw
60 °C
< 6 A
< 1.5 A
< 0.7 A
< 4 A
< 1 A
-

Miniature industrial relay for decoupling PLC's, multiplying signals, and switching industrial small loads < 1.5 A.

**RCH 2 CO FG**

2723360000
2706430000
reinforced insulation
AgNi
12.8 mm
PUSH IN and screw
60 °C
< 6 A
< 2.5 A
< 0.8 A
< 6 A
< 1.5 A
-

Miniature industrial relay with forcibly guided contacts according to EN 61810-3 type B for decoupling of PLC's and for switching of industrial small loads < 2.5 A.

**DRI 1 CO**

7760056315
2576210000
basic insulation
AgSnO
16 mm
PUSH IN and screw
55 °C
< 10 A
< 3 A
< 1 A
< 8 A
< 2 A
-

Miniature industrial relay with optional mechanical test button for decoupling PLC's and switching industrial small loads < 3 A.

**DRI 2 CO**

7760056340
2576190000
basic insulation
AgSnO
16 mm
PUSH IN and screw
55 °C
< 5 A
< 1.5 A
< 0.5 A
< 4 A
< 1 A
-

Miniature industrial relay with optional mechanical test button for decoupling PLC's, multiplying signals, and switching industrial small loads < 1.5 A.

**DRM 2 CO**

7760056069
2576120000
basic insulation
AgNi
31 mm
PUSH IN and screw
55 °C
< 10 A
< 2.5 A
< 1 A
< 7 A
< 2 A
-

Miniature industrial relay with optional mechanical test button for decoupling PLC's, multiplying signals, and switching industrial small loads < 2.5 A.

**DRM 4 CO**

7760056097
2576140000
basic insulation
AgNi
31 mm
PUSH IN and screw
55 °C
< 5 A
< 1.5 A
< 0.5 A
< 3.5 A
< 1 A
-

Miniature industrial relay with optional mechanical test button for decoupling PLC's, multiplying signals, and switching industrial small loads < 1.5 A.

# Switching of large resistive and inductive loads

## Selection table for power relays

The table below helps you to select suitable relay modules for the specified loads. A service life of around 100,000 switching operations is assumed.

### D-SERIES



	DRR 2 CO	DRR 3 CO	DRL 1 CO	DRL 2 CO	DRL 3 CO	DRL 4 CO
Example Part no. Single relay	2765020000	2765070000	2765110000	2765160000	2765220000	2765270000
Example Art. no. KIT 24 V DC input	-	-	-	-	-	-
Insulation between input and output	Basic insulation	Functional insulation	Basic insulation	Basic insulation	Basic insulation	Basic insulation
Contact material	AgSnO	AgSnO	AgSnO	AgSnO	AgSnO	AgSnO
Width plugged on socket	38 mm	38 mm	24 mm	24 mm	34 mm	44 mm
Socket connection technologies	Screw	Screw	Screw	Screw	Screw	Screw
Max. Operating temperature	55 °C	55 °C	55 °C	55 °C	55 °C	55 °C
Resistive AC load AC1 loads: Heaters 250 V AC	< 10 A	< 10 A	< 16 A	< 10 A	< 10 A	< 10 A
Inductive AC load AC15 loads: Valves, contactors 250 V AC3 loads: 1-phase motors 250 V AC	< 3.5 A	< 3.5 A	< 5.5 A	< 4.5 A	< 4.5 A	< 4.5 A
	< 1.5 A	< 1.5 A	< 3.5 A	< 2 A	< 2 A	< 2 A
Resistive DC load DC1 loads: Heaters	< 10 A	< 10 A	< 10 A	< 7 A	< 7 A	< 7 A
Inductive DC load DC13 loads: Valves, contactors 24 V DC	< 2.5 A	< 2.5 A	< 4 A	< 3.5 A	< 3.5 A	< 3.5 A
Inrush current optimized	-	-	-	-	-	-
Recommended field of application	Power relay (octal relay) for switching several industrial loads < 3.5 A.	Power relay (octal relay) for switching several industrial loads < 3.5 A.	Miniature power relay for switching industrial loads < 5.5 A.	Miniature power relay for switching several industrial loads < 4.5 A.	Miniature power relay for switching several industrial loads < 4.5 A.	Miniature power relay for switching several industrial loads < 4.5 A.

The indicated currents only apply to the normally open contact. The data of the normally closed contact are to be set at approx. one third of the specified values. The real service life can be both above and below the specified value because each load stresses the switching contact differently and other environmental factors influence the service life of the switching contact, e.g. ambient temperature, mounting position, switching frequency, and many more. Therefore, these values are without guarantee and serve as orientation for better dimensioning. They may not be used as B10 or B10d values for the calculation of failure data such as MTTf or MTTfd either. The assessment of the maximum load capacity was carried out on the basis of many years of practical experience as well as life cycle tests under laboratory conditions.

POWER



DRW 2 CO	DRW 3 CO	DRH 1 NO	DRH 2 NO	PWR 1 NO	PWR 2 NO
2765600000	2765650000	1219850000	1220150000	1219480000	1219550000
-	-	-	-	-	-
Basic insulation	Basic insulation	Basic insulation	Basic insulation	Basic insulation	Basic insulation
AgSnO	AgSnO	AgSnO	AgSnO	AgSnO	AgSnO
39 mm	39 mm	39 mm	39 mm	51 mm	51 mm
Screw	Screw	Screw	Screw	Screw	Screw
60 °C	60 °C	60 °C	60 °C	55 °C	55 °C
< 16 A @ 250 V < 10 A @ 400 V	< 16 A @ 250 V < 10 A @ 400 V	< 16 A @ 400 V	< 16 A	< 30 A	< 25 A
< 5.5 A	< 5 A	< 7 A	< 6 A	< 12 A	< 8.5 A
< 3.5 A	< 3 A 1-phasing < 3 A 3-phasing	< 4 A	< 3.5 A	< 8 A	< 6 A
< 16 A	< 16 A	< 16 A @ 24 V DC < 12 A @ 125 V DC < 10 A @ 220 V DC	< 16 A @ 24 V DC < 7 A @ 125 V DC < 3 A @ 220 V DC	< 25 A	< 20 A
< 4 A	< 3.5 A	< 12 A @ 24 V DC < 5 A @ 125 V DC < 3 A @ 220 V DC	< 9 A @ 24 V DC < 2 A @ 125 V DC < 1 A @ 220 V DC	< 7 A	< 6 A
-	-	-	-	-	-
Power relay with mechanical test button for switching multiple industrial loads < 5.5 A.	Power relay with mechanical test button for switching industrial loads < 5 A or a 3-phase electric motor < 3 A.	Power relay with blow out magnet and mechanical test button specially designed for switching industrial loads with high DC voltage up to 220 V DC 3 A.	Power relay with blow out magnet and mechanical test button especially for switching industrial loads with high DC voltage up to 220 V DC 1 A.	Power relay (miniature contactor) with double contact opening for switching industrial loads < 12 A.	Power relay (miniature contactor) with double contact opening for switching industrial loads < 8.5 A.

## Additional information on the selection tables

### Simple formulas for calculating individual values

#### Calculating the service life of the relay contacts for different switching currents

In the previous tables we gave you the maximum recommended currents at various loads for a service life of approx. 100,000 switching cycles. If you switch lower currents, the service life of the relay contacts will be extended. With the following formulas you can approximately calculate how the service life of the relay contacts will change.

**Example:** A 24 V DC solenoid valve with 200 mA current consumption should be switched with a 6.4 mm wide TERMSERIES RSS 1 CO relay. A solenoid valve corresponds to a DC13 load. According to the table, a switching current of max. 1 A is specified for the relay at this load. To calculate the expected service life, proceed as follows:

$$x = \frac{I_{\text{Table}}}{I_{\text{App}}} = \frac{1 \text{ A}}{200 \text{ mA}} = 5$$

$$n_{\text{new}} = 100,000 \cdot x = 100,000 \cdot 5 = 500,000 \text{ switching cycles}$$

The expected service life when switching a 200 mA solenoid valve should be approx. 500,000 switching cycles.

$I_{\text{App}}$	= Switching current in the application
$I_{\text{DC}}$	= DC Switching current at the DC switching voltage in the application
$I_{\text{Load curve}}$	= DC Switching current from the load limit curve of the data sheet
$I_{\text{Nom}}$	= Continuous current from relay data sheet
$I_{\text{Table}}$	= Switching current from the selection table for the respective load
$n_{\text{new}}$	= Service life at switching current in the application
$x$	= Reduction factor of the switching current

#### Calculating the switching currents for voltages that deviate from the values in the table

##### AC switching voltage:

With AC loads, the switching current has the greatest influence on the service life. Therefore, the switching currents from the table can also be used for switching voltages up to 100 V AC. For values below 100 V AC, the service life in-creases at the same switching current:

- at 24 V AC four times the service life
- at 60 V AC twice the service life

**Example:** If the table shows a switching current of 2 A for a 250 V AC AC15 load, then these 2 A are also applicable for 120 V AC. At 24 V AC switching voltage, the expected service life increases four times to 400,000 switching cycles.

##### DC switching voltage:

When switching DC loads, the switched voltage has a large influence on the maximum switching current of the relay contact. This can also be seen from the DC load breaking curve given in the data sheet. The following formulas can be used to roughly determine the maximal switching current for other DC switching voltages:

**Example:** A TERMSERIES RCL 1 CO relay with a DC13 load and a switching voltage of 110 V DC. According to the table a maximum of 2 A at 24 V DC applies to a DC13 load for a service life of 100,000 switching cycles.

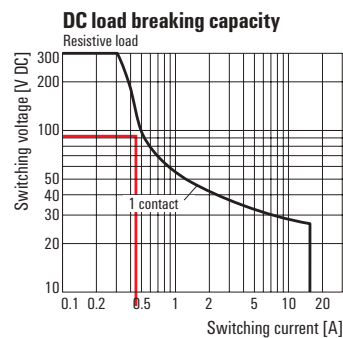

The curve shows a maximum switching current of approx. 0.45 A with resistive load. This must now be set in relation to the rated current of the relay (16 A) from the data sheet and the value for a DC13 load from the table.

$$x = \frac{I_{\text{Table}}}{I_{\text{Nom}}} = \frac{2 \text{ A}}{16 \text{ A}} = 0.125$$

$$I_{\text{DC}} = I_{\text{Load curve}} \cdot x = 0.45 \text{ A} \cdot 0.125 = 0.056 \text{ A} = 56 \text{ mA}$$

To achieve 100,000 switching cycles, a DC13 load of 56 mA can be switched with a switching voltage of 110 V DC.

# Select contact materials suitable for the application

## Information of various contact materials





Relay modules are used in a wide variety of industrial areas and environments. The relays must therefore be adapted to the various tasks by selecting suitable contact materials. The following applies: the load capacity of the contacts for voltage, current, and power depends essentially on the material used. To make the selection easier for you, we have compared the most important characteristics of the contact materials.

### Criteria for the selection of the contact material:

- Welding tendency
- Burn-off resistance
- Contact resistance
- Material migration
- Resistance to harmful gas atmospheres

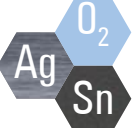

Please obtain information when selecting a relay in this table:

Material	Characteristics	Recommended applications
 Silver-nickel	<ul style="list-style-type: none"> <li>• Higher welding tendency than AgSnO</li> <li>• High burn-off resistance</li> <li>• Lower contact resistance than AgSnO</li> <li>• Mean material migration</li> <li>• Low resistance to harmful gas atmospheres</li> </ul>	<ul style="list-style-type: none"> <li>• Suitable for low to high resistive and low inductive load (solenoid valves, fans, heaters)</li> <li>• Standard contact material for a variety of relays</li> <li>• Limited suitable for high inrush currents</li> <li>• Suitable for loads &gt; 12 V/10 mA or 5 V/100 mA</li> </ul>
 Silver-nickel flash gold plated	<ul style="list-style-type: none"> <li>• Higher welding tendency than AgSnO</li> <li>• High burn-off resistance (gold just storage protection)</li> <li>• Lower contact resistance than AgSnO</li> <li>• Mean material migration</li> <li>• Low resistance to harmful gas atmospheres</li> </ul>	<ul style="list-style-type: none"> <li>• Suitable for low to high resistive and low inductive load (solenoid valves, fans, heaters)</li> <li>• The flash gold plating is a storage protection, but offers no functional improvement to AgNi</li> <li>• Limited suitable for high inrush currents</li> <li>• Suitable for loads &gt; 12 V/10 mA or 5 V/100 mA</li> </ul>
 Silver-nickel hard gold plated	<ul style="list-style-type: none"> <li>• Very low resistance to burn-off</li> <li>• Lowest contact resistance</li> <li>• High resistance to harmful gas atmospheres</li> </ul>	<ul style="list-style-type: none"> <li>• Suitable for decoupling control inputs and other small resistive loads</li> <li>• Suitable for loads &gt; 1 V/1 mA and &lt; 30 V/10 mA</li> <li>• After switching loads &gt; 30 V/100 mA, small powers can no longer be switched reliably because the hard gold plating has been burned-off. Only the characteristic of the base contact material AgNi still apply.</li> </ul>
 Silver-Tin-Oxide	<ul style="list-style-type: none"> <li>• Lower welding tendency than AgNi</li> <li>• High resistance to burn-off</li> <li>• Average contact resistance</li> <li>• Lower material migration than AgNi</li> <li>• Very low resistance to harmful gas atmospheres</li> </ul>	<ul style="list-style-type: none"> <li>• Suitable for medium to high resistive DC-loads and low up to medium inductive DC loads due to low material migration. Thanks to the low tendency to weld, it is also well suited for load with higher inrush currents such as lamp loads, light capacitive loads, fluorescent tubes, etc.</li> <li>• Suitable for loads &gt; 12 V/100 mA</li> </ul>
 Tungsten	<ul style="list-style-type: none"> <li>• Lowest welding tendency</li> <li>• Very high resistance to burn-off</li> <li>• Highest contact resistance</li> <li>• Low material migration</li> </ul>	<ul style="list-style-type: none"> <li>• Suitable for loads with very high inrush currents of up to 165 A/20 ms or 800 A/200 μs (e.g. lamp loads, capacitive loads, fluorescent tubes, switched-mode power supplies etc.)</li> <li>• Often used as a pre-making contact in parallel to AgSnO contacts</li> </ul>

## Protect relay contacts effectively

### Selection criteria for protective circuits of inductive loads

In our selection tables we specified the maximum recommended switching currents for inductive loads without protective circuits. If you want to increase the service life of the contacts, you must equip the relay contacts with an effective protective circuit.

The protective circuit on the coil side of a relay module can, for example, be implemented with an integrated or additionally pluggable freewheeling diode. However, this only protects the controlling periphery from the voltage peaks that occur in the coil of the relay module. The relay contact is usually not sufficiently protected against the voltage peaks of the inductive load to be switched, although with optimum dimensioning almost the same values for switching capacity or switching cycles can be achieved as with resistive load.

The largest reduction factor for the service life of a relay contact is the arc generated during switching off inductive loads. It is caused during the switching process by the energy stored in the coil and can destroy the contact through material evaporation and material migration.

With DC voltage and standing arc, the relay can even fail during the first switching cycle. Voltage peaks caused by electric arcs can reach values up to several 1,000 volts.

A protective circuits must be used to suppress the formation of electric arcs.

In the following, we will explain the correct installation of the protective circuit and the effectiveness of the most common types of protective circuit. There are various ways to install an effective protective circuits. For example, the protective circuit can be mounted either parallel to the relay contact or parallel to the load.

However, the protective measure should always apply directly to the source of the fault. Therefore, the protective circuit of the load is preferable to the circuit of the contact.

#### Advantages of a protective circuit at the load:

- When the contact is open, the load is still galvanically isolated from the operating voltage
- The switch-off peaks of the load cannot be coupled into the control lines running in parallel



### Free-wheeling diodes

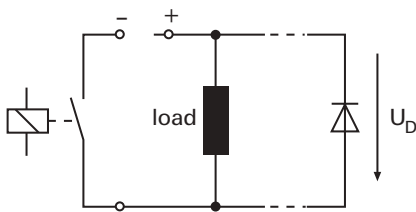

Free-wheeling diodes are used to protect against overvoltages caused by self-induction when an inductive DC voltage load is switched off (e.g. solenoid valves or electric motors). They ensure that the voltage peaks that occur are reduced to the value of the diode forward voltage ( $U_D$ ). However, this leads to a delay in the voltage drop and thus in the switch-off process of the load.

#### Advantage:

- Uncritical dimensioning
- Very positive effect on the service life of the contacts

#### Disadvantage:

- Significantly extended switch off process
- Only suitable for DC voltage

### Varistors

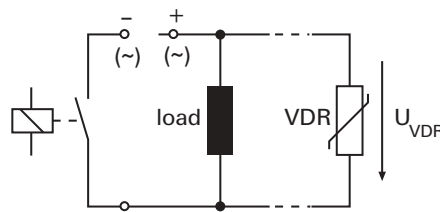

The functional principle of varistors is also based on breakdown voltages ( $U_{VDR}$ ). High energies can be dissipated, but this causes the component to aging. Therefore, the breakdown voltage is reduced over time and the leakage current is increased.

#### Advantage:

- Uncritical dimensioning
- Suitable for DC and AC voltage
- Slightly extended switch off process

#### Disadvantage:

- Complex and expensive with increasing power
- Low effect on the service life of the contact

### RC modules

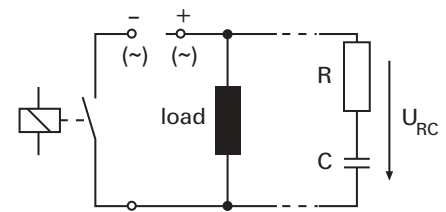

With RC modules, voltage peaks are compensated via a capacitor. Thanks to its special characteristics during charging and discharging the interference pulses are already filtered out during the voltage rise and not only when the breakdown voltage ( $U_{RC}$ ) is reached.

#### Advantage:

- Suitable for DC and AC voltage
- Slightly extended switch off process

#### Disadvantage:

- Exact dimensioning required
- High inrush current
- Low effect on the service life of the contact



In order to implement a protective circuit tailored to the load, suitably dimensioned protective circuits are available as accessories from many manufacturers of inductive loads such as contactors or solenoid valves. This enables simple integration of the protective circuit on the load.

## Switching of capacitive loads

### Relays for LED lamps and devices with high inrush currents

Loads with capacitive load shares, especially LED lamps, require extreme demands on switching contacts regardless of the voltage type. They cause highly energetic current peaks at the moment of switch-on. These can reach over 150 A and weld the contact.

Until a few years ago, the lighting of buildings and facilities was provided almost exclusively by light bulbs or fluorescent tubes of buildings and facilities. Nowadays, they are replaced by LED lamps, which consume much less power and are often much more durable. With retrofit solutions, such as LED lamps with E27 bases, this can be done quite easily. In new installations, LED lights are provided anyway.

However, problems often arise with relay circuits, such as those found in staircase illumination: LED lamps generate very strong inrush currents due to their design. Although these are much shorter than with conventional light sources, they can generate currents of over 150 A and thus weld the relay contact at the moment of switch-on. Therefore, when switching LED lamps with standard relays, welded contacts occur after a very short time, sometimes even after the first switch-on. Furthermore, in more and more conventional industrial loads, such as solenoid valves and contactors, capacitive load shares are hidden in input circuits, as these enable operation over a wide input voltage range. In order to switch such loads reliably, relays specially designed for this purpose are required. These relays have special contact materials and designs that can reliably switch significantly higher current peaks than conventional relays with e.g. AgNi as contact material.

Exemplary inrush current curve

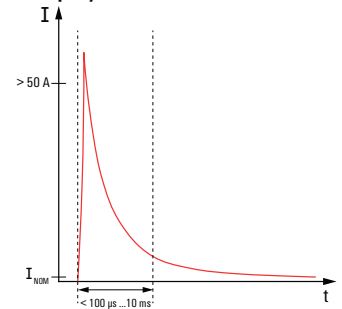

The characteristics of the various contact materials are listed below and assigned to recommended areas of application:

## TERMSERIES

### Special relay modules with tungsten contact for very high inrush currents of up to 800 A for 200 µs

Single relay, 12.8 mm wide	Order No.
RCLS3T024W	8866920000
Complete module/KIT, 12.8 mm wide	
TRP 24VDC 1NO HCP	2617930000
TRS 24VDC 1NO HCP	1479810000
TRP 24-230VUC 1NO HCP ED2	2663140000
TRS 24-230VUC 1NO HCP ED2	2662980000

### Special relay modules without tungsten contact for high inrush currents of up to 80 A for 20 ms

Single relay, 12.8 mm wide	Order No.
RCLS3L024W	1984080000
Complete module/KIT, 12.8 mm wide	
TRP 24VDC 1NO HC	2618090000
TRS 24VDC 1NO HC	1479780000
TRP 24-230VUC 1NO HC ED2	2663130000
TRS 24-230VUC 1NO HC ED2	2662970000

### Solid state relays for short and high inrush currents (<10 ms) e.g. of LED lamps or devices with wide range inputs

Pluggable solid-state module DC output, 12 mm wide	Order No.
SSR 10-32VDC/0-35VDC 5A	1421450000
SSR 24VDC/0-24VDC 3,5A	1132310000
Pluggable solid-state module DC output, 5 mm wide	
SSS Relais 24V/24V 2Adc	4061190000
Complete module/KIT, 12.8 mm wide	
TOP 24VDC 24VDC5A	2618840000
TOS 24VDC 24VDC5A	1990960000
TOP 24VDC 24VDC3.5A	2618700000
TOS 24VDC 24VDC3.5A	1127630000
Complete module/KIT, 6.4 mm wide	
TOP 24VDC 24VDC2A	2618720000
TOS 24VDC 24VDC2A	1127170000
Pluggable solid-state module, AC output, 5 mm wide	
SSS Relais 24V/230V 1Aac	4061210000
Complete module/KIT, 6.4 mm wide	
TOP 24VDC 230VAC1A	2618420000
TOS 24VDC 230VAC1A	1127410000

## MICROOPTO

### Solid state relays for short and high inrush currents (<10 ms) e.g. of LED lamps or devices with wide range inputs

Complete module, 6.1 mm wide	Order No.
MOS 24VDC/8-30VDC 2A	8937970000
MOS 24VDC/8-30VDC 2A E	1283230000



Visit our online catalogue  
for more information  
[eshop.weidmueller.com](http://eshop.weidmueller.com)

## Switching of very low power circuits

### Relay for forwarding control signals

# A

Low power circuits with values below 30 V/10 mA are mainly used in applications where signals has to be transmitted to control inputs, e.g. to a PLC. Such low loads do not produce a sufficient arc at the contacts.

However, this arc has two important functions:

On the one hand, it ensures continuous cleaning of the contacts; on the other hand, it can penetrate non-conductive foreign layers at the contacts. Such foreign layers are usually created by oxidation or sulfidation of common contact materials such as silver (Ag), silver-nickel (AgNi), or silver-tin oxide (AgSnO). The foreign layers can increase the contact resistance after a short time to such an extent that reliable switching of low loads is no longer possible.

For these reasons, gold (Au) is used as the contact material for relays switching small loads. It has proven itself due to its low and constant contact resistance and its resistance to ambient air containing sulphur.



Visit our online catalogue  
for more information  
[eshop.weidmueller.com](https://eshop.weidmueller.com)



**TERMSERIES**

The all-rounder. Modular relay modules from 6 mm width with extensive accessories, large selection of variants, and unlimited cross-connection possibilities.

Single relay, 5 mm wide	Order No.
RSS112024	4061590000
Complete module/KIT, 6.4 mm wide	
TRP 24VDC 1CO AU	2618110000
TRS 24VDC 1CO AU	1123000000

Single relay, 12.8 mm wide	Order No.
RCL425024	4058580000
Complete module/KIT, 12.8 mm wide	
TRP 24VDC 2CO AU	2618530000
TRS 24VDC 2CO AU	1123730000

**D-SERIES**

Industrial relay modules with innovative features and a large selection of variants for various applications.

Single relay, 21 mm wide	Order No.
DRM270024LT Au	7760056185
DRM570024LT Au	7760056189

# Forced guided contacts explained in detail

## The difference to relays with conventional contacts

Relay modules with forcibly guided contacts use elementary relays according to IEC 61810-1 with a contact set according to IEC 61810-3. From the outside, they can hardly be differentiated from relays with conventional contacts, if at all. Due to their design, an opening failure of forcibly guided contacts can be reliably detected. Relays with such contacts have the following additional characteristics compared to relays with conventional contacts:

- Forcibly guided NC and NO contacts are designed in such a way that they cannot be closed at the same time
- If a contact of a forcibly guided contact set is welded, the antivalent contacts cannot close and the contact opening must be  $> 0.5 \text{ mm}$
- The contacts are located in contact chambers and are thus specially protected against other contacts and against the coil

Due to these normative requirements, the design and manufacturing effort for relays with positively driven contacts is much higher.

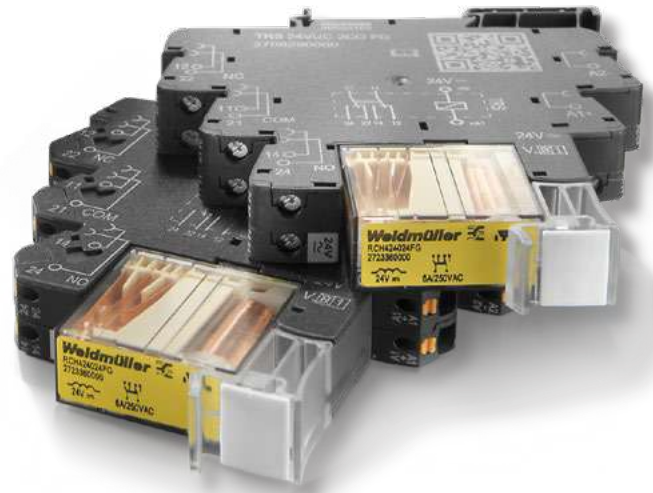

### conventional relay

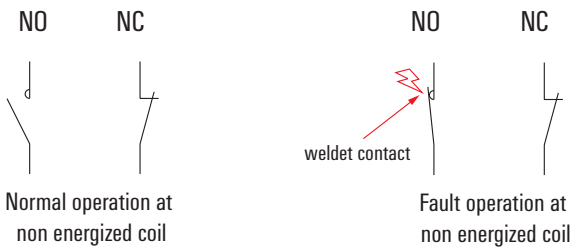

### relay with forcibly guided contacts

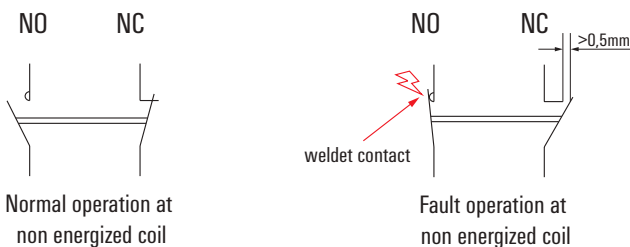

The normally open contact (NO) is welded in this example. With standard relays, a normally closed contact (NC) can also be closed in case of the de-energized state. In this way, the NC and NO contacts can be closed at the same time and an opening failure cannot be reliably detected.

The normally open contact (NO) is welded in this example. In this case, relays with forcibly guided contacts cannot have a normally closed contact (NC) which is closed in the de-energized state. In this way, the NC and NO contacts cannot be closed at the same time and an opening failure can be reliably detected. It is mechanically ensured that the NC contact remains open with a minimum contact gap of 0.5 mm even in the de-energized state.



In addition, the standard distinguishes between two types of positive guidance, type A and type B:

## Type A

With type A relays, **all** contacts are mechanically positively driven with each other.

In an example of a six-pole relay with four NO contacts and two NC contacts, the four NO contacts are forcibly guided with both NC contacts. In this example, if one of the NO contacts welds, both NC contacts may no longer close if the relay is de-energized.

**Type A relays with forcibly guided contacts can be found in our SAFESERIES Contact Extension.**

## Type B

In a type B relay, **not all** contacts of a contact set are positively driven with each other.

In an example of a six-pole relay with four NO contacts and two NC contacts, the four NO contacts are forcibly guided with just one of the NC contacts. In this example, if one of the NO contacts welds, the non-force-guided NC contact can still close if the relay is de-energized.

The other forcibly guided NC contact may not close. The status of the other NO contacts is undetermined. The non-force-guided NC contact can close because it is not forcibly guided to the other contacts in the relay. The contacts which are not forcibly guided must be specified in the data sheet.

Positively driven relays with changeover contacts (CO) are assigned to type B by the standard, only one NC or NO contact may be used per changeover contact. The reason for this is that the phenomenon of contact spring breakage cannot be excluded, so that in the event of a spring breakage of a changeover contact set, the NO and NC contacts of this contact set can be short-circuited.

**Type B relays with forcibly guided contacts can be found in our TERMSERIES FG.**



Visit our online catalogue for more information  
[eshop.weidmueller.com](https://eshop.weidmueller.com)

## B10(d) + MTTF(d)

### Short explanation and example calculation

#### 1. Introduction of MTTF and MTBF

Failure data such as MTTF (Mean Time To Failure) or MTBF (Mean Time Between Failure) are becoming increasingly important in the planning of machinery. This article will explain the importance of these values for electromechanical relays and solid state relays.

For the planning of electrical machines, it is necessary to know the MTBF values for the individual components such as relays in order to calculate the probability of failure for the entire system. MTBF is the mean time between failures, so it includes the mean operating and the mean repair time (MTTR = Mean Time To Repair). MTBF, MTTF and MTTR values are usually given in years. However, in the case of electronic components such as relays, the repair time is not determined because it is not economical to repair defective relays. They are replaced after they are worn. That is why relays are referred just to MTTF. So you can also say: MTBF is equal to MTTF for electromechanical relays and solid-state relays. The MTTF value is a statistical key figure/parameter. It is determined by tests and empirical values and therefore gives no guarantee of a certain service life.

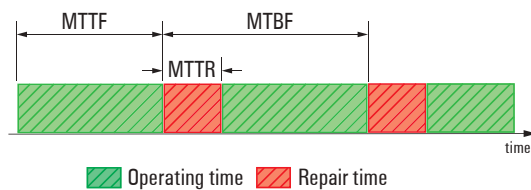

#### Difference between MTTF and MTTFd

The difference between MTTF and MTTFd (Mean Time to Failure dangerous) is that the MTTF value indicates the mean operating time to (any) failure, while the MTTFd value indicates the mean operating to a dangerous failure. Non-dangerous failures can lead to machine damage, but they are not relevant for safety considerations within the risk and hazard assessment. The MTTF value for individual components is usually obtained directly from the manufacturer. However, the manufacturer cannot provide an MTTFd value because he cannot ultimately assess which error in the application leads to a dangerous failure at the customer. In addition, the arrangement and alignment of several elements can also have an influence on the total time span until a dangerous failure. Above all, the possibility of executing a function in two channels and therefore redundant has a considerable influence on the MTTFd value of the entire system.

This means that the MTTFd must be determined by the person who develops the machine/plant and also plans the safety functions. This is usually the developer or the designer. These persons can calculate the MTTFd.

**MTTF for electromechanical relays**

With electromechanical relays, the service life is strongly dependent on the number of switching cycles, the switched load and other environmental parameters such as temperature, mounting orientation, switching frequency and many more. This is because electromechanical relays are subject to mechanical and electrical wear, mainly due to contact erosion. For these reasons, the MTTF cannot be calculated from statistical values as it is the case with a solid-state relays, instead B10 values are determined. These B10 values are determined in complex and time-consuming test setups for various load cases, so there is only a selection of different B10 values and not every possible combination of switching current, load type and environmental parameters.

**B10-value**

The B10 value indicates the nominal service life in switching cycles where 90% of a unit of tested relays still work. It is therefore the average number of switching cycles, according to which 10% of relays are to be expected to fail. This value is a statistical expected value that was determined on the basis of lifetime tests. In real applications, the lifetime values differ from the B10 value, as each load is different and the environmental parameters, such as humidity, air pollution, heat, vibrations, radiation, etc., have an influence on the service life.

The loads used for the determination of the B10 values are specified in the contactor standard EN 60947 in different categories of use such as z.B. DC-13 or AC-15. However, users must be aware that these loads reflect practice only to a limited extent. Because all DC-13 and AC-15 test loads are highly inductive and operate without a protection circuit. Furthermore, the B10 values are determined at significantly higher switching frequencies than usual in reality. This is done to shorten the test execution time, otherwise tests would take years to deliver a result. An increased switching frequency also represents an increased load on the relay than usual in reality. However, it is almost impossible to compare B10 values of different providers. To compare different relays, the relays would have to be measured in exactly the same test setup. For this reason, the B10 values are often only provided by the manufacturer on request.

**MTTF calculation using the B10-value**

For the calculation of the MTTF value, the respective B10 value which most closely corresponds to the real application is converted into the following formula from the standard EN ISO 13849-1:

$$\text{MTTF} = \text{B10} / (0,1 \times \text{annual switching cycles in the application})$$

The annual switching cycles in the application must be determined by the user himself.

**B10d-value**

The B10d indicates the number of switching cycles according to which a dangerous failures occur in 10 % of the units considered. The addition "d" stands for "dangerous". The value is for the creationa risk and hazard analysis relevant and thus also for the evaluation of the safety of a machine or plant. If there is no knowledge of the number of hazardous failures, EN ISO 13849-1 recommends the following calculation for the B10d value:

$$\text{B10d} = \text{B10} \times 2$$

This means that it is assumed that every second failure is a dangerous failure.

**MTTFd calculation using the B10d-value**

For the calculation of the MTTFd value, the respective B10d value which most closely corresponds to the real application is converted into the following formula from the standard EN ISO 13849-1:

$$\text{MTTFd} = \text{B10d} / (0,1 \times \text{annual switching cycles in the application})$$

The annual switching cycles in the application must be determined by the user himself.

## 2. Exemplary MTTF calculation of an electromechanical relay

### B10 values available for the relay:

90,000 switching cycles at a DC13 load: 24 V DC / 1.5 A

250,000 switching cycles at an AC15 load: 230 V AC / 3 A

400,000 switching cycles at one AC1 load: 230 V AC / 6 A

### Application:

Switching a solenoid valve: 230 V AC / 2 A

### Switching frequency of the relay:

3x per minute

### Operating hours of the plant:

250 days a year

22 hours a day

1) First, the appropriate B10 value of the relay for the application is selected.

Since a solenoid valve at 230 V AC is very similar to an AC15 load, this value is selected for the calculation:

250,000 switching cycles at an AC15 load: 230 V AC / 3 A

2) After that, the annual switching cycles of the relays must be determined. This is determined with the following formulas:

Formula signs:

$t_{\text{Zyklus}}$  = Mean time between two consecutive cycles in seconds

$h_{\text{op}}$  = Average operating time in hours per day (0 - 24 hours)

$d_{\text{op}}$  = Average operating time in days per year (0 - 365 days)

$n_{\text{op}}$  = Average number of switching cycles per year

$t_{\text{Zyklus}} = 60 \text{ seconds} / \text{switching frequency of the relay per minute}$

$t_{\text{Zyklus}} = 60 \text{ seconds} / 3 = 20 \text{ seconds}$

$n_{\text{op}} = (d_{\text{op}} \times h_{\text{op}} \times 3600 \text{ s/h}) / t$

$n_{\text{op}} = (250 \text{ days/year} \times 22 \text{ hours/day} \times 3600 \text{ seconds/hour}) / 20 \text{ seconds}$

$n_{\text{op}} = 990,000 \text{ switching cycles/year}$

3) Calculation of the MTTF

$\text{MTTF} = \text{B10} / (0.1 \times \text{Annual switching cycles in the application})$

$\text{MTTF} = 250,000 \text{ switching cycles} / (0.1 \times 990,000 \text{ switching cycles/year})$

$\text{MTTF} = 2.52 \text{ years}$

The MTTF for the sample relay is therefore 2.52 years.

### 3. MTTF for solid-state relays

The MTTF value for solid-state relays is calculated from the failure rates of the individual electronic components, as they have no mechanical components that wear out due to mechanical abrasion or contact burn-off. The MTTF values of the Weidmüller solid-state relays can be found in the data sheet. The calculation was carried out in accordance with the standards SN 29500 and EN ISO 13849-1. The value refers to an ambient temperature of 40°C. When calculating the values for solid-state relays, the following things are not taken into account:

- Electrical connections and plug-in connections
- PCB (not included in the SN29500 standard)
- Soldering process due to quality control processes in manufacturing





# Universal range

<b>Universal range</b>	Overview	B.2
	TERMSERIES-compact - relay modules	B.4
	TERMSERIES-compact - with fuse carrier	B.18
	TERMSERIES-compact - relay modules for the railway industry	B.20
	TERMSERIES - relay modules	B.30
	TERMSERIES TIMER - timer function	B.74
	TERMSERIES FG - with forcibly guided contacts	B.76
	TERMSERIES - solid-state relays	B.78
	TERMSERIES - Cl.1 Div.2	B.92
	Accessories TERMSERIES-compact & TERMSERIES	B.96
	TERMSERIES Interface Adapter	B.104
	CUBESERIES - relay modules	B.110
	D-SERIES - relay modules	B.124
	MCZ SERIES - relay modules	B.184
	MCZ-SERIES - solid-state relays	B.192

# Universal range

## Relay modules and solid-state relays for every application

### B

Machinery and plant engineering is full of challenges. One of these challenges is the selection of suitable relay products. A wide range of highly flexible modules are needed here that can satisfy a variety of different requirements.

As a full-range supplier in the field of relay modules, we provide you with a broad, varied and high-quality relay portfolio with products from the TERMSERIES-compact, TERMSERIES, CUBESERIES and D-SERIES. In addition, we offer KITS for signal isolation, amplification and multiplication. They are distinguished by particularly high reliability and durability and are available in various designs. In addition to our products, we offer you a wide range of comprehensive services and guidelines. This also includes our services for data support as well as for the digital availability of product data, with which we make your entire planning cycle easier.

Our relay modules are used in automation technology as well as in many other areas and industries for galvanic isolation. They are available with different types of contact such as NO contact, NC contact and CO contact and, due to their functional excellence, they provide measurable cost reductions for storage, installation and operation.

#### **Solid-state relays**

Our high-quality solid-state relays combine the highest standards with absolute quality. The extremely flexible portfolio includes a wide range of compact, durable, wear-free, silent and vibration-resistant products. For you this means: no mechanical wear, no error conditions and no noise pollution.

#### **Electromechanical relays**

Electromechanical relays are a versatile and cost-effective solution for a wide range of switching processes. They can be used for level and power adjustment and form interfaces between control, signalling or regulating equipment and the peripheral devices. However, due to the diversity of their industrial applications, the right relay must be selected for each specific application. In addition, electromechanical relays are subject to a certain amount of wear due to their design, which must also be taken into account when designing relay circuits.

**Convenient for planning and documentation**

Thanks to the electronic catalogue, product data can be imported and exported to all common engineering tools such as EPLAN. It therefore also supports the use of digital twins and guarantees fast access to all item data at all times.

**Compact and time-saving**

The compact design of our relay modules saves a lot of space in the panel. The reduced wiring effort as well as optimal marking enable time-saving installation and maintenance.

**Functional and economical**

The high functional demands of our relay modules ensure measurable cost savings – through simplified storage, time-saving wiring and reliable operation, for example.

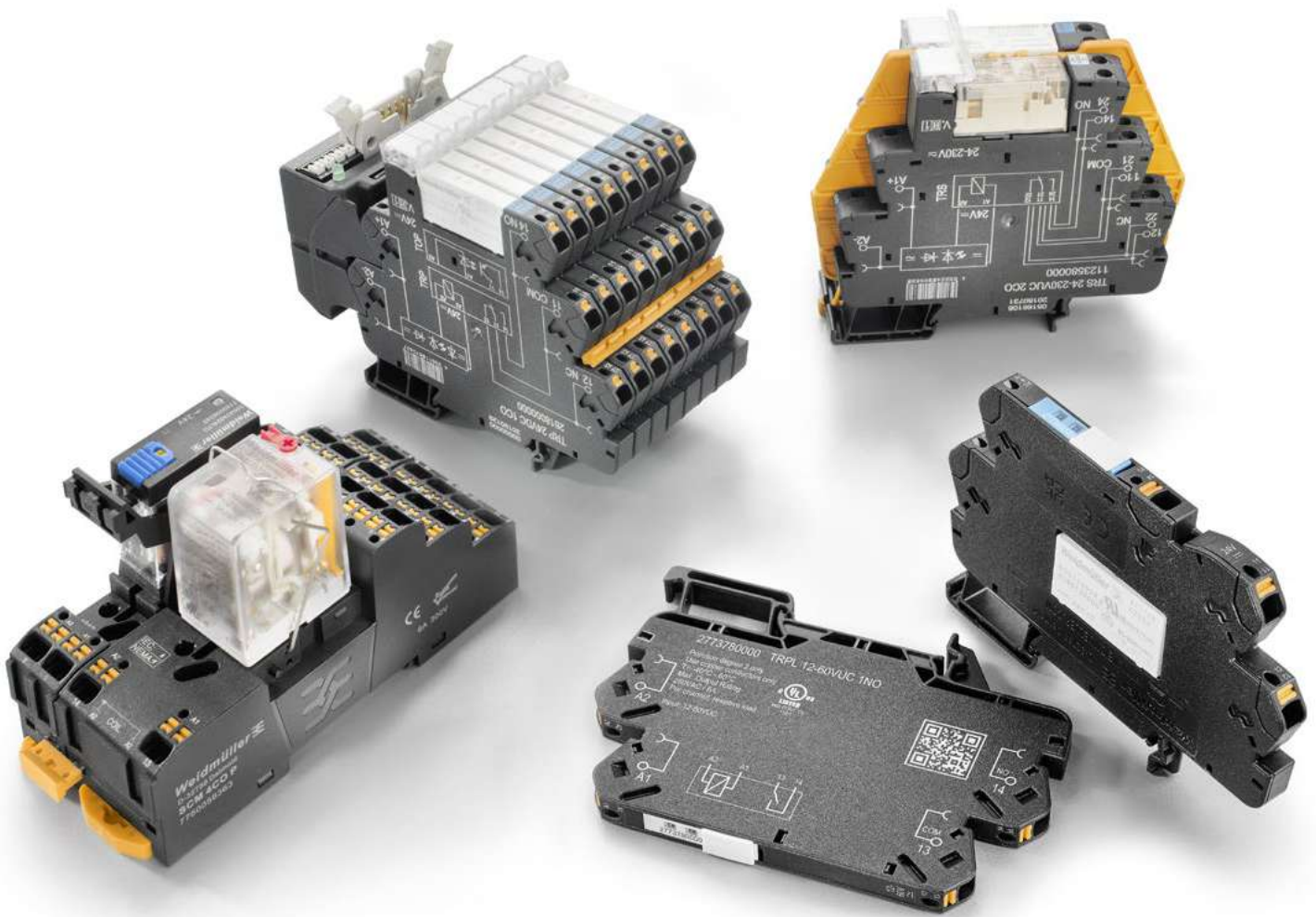

**High quality and versatile**

Our solid-state relays combine the latest standards with the highest quality. You benefit from a wide and flexible product range with maximum safety

**Robust and reliable**

Fail-safe, wear-free, low-noise and vibration-proof components ensure interference-free work processes and safeguard the availability of the plant.

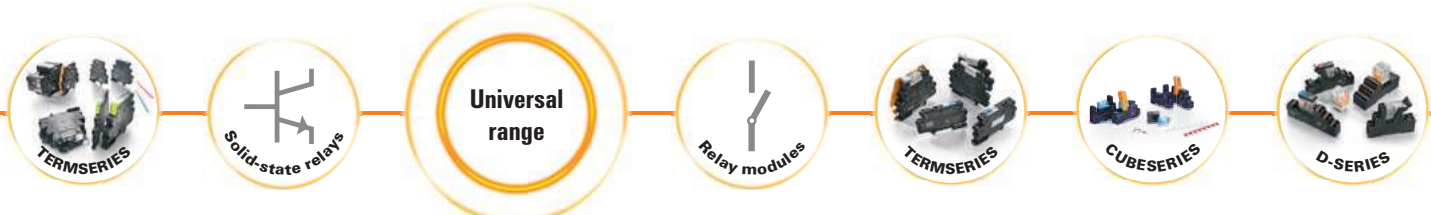

# TERMSERIES-compact

## Universal relay with maximum vibration resistance

### B

To achieve maximum machine and system availability, many relays must also function reliably in environments with strong vibrations. In addition, compact modules for flat control cabinets are required. TERMSERIES-compact fulfils both demands.

The new, ultra-compact complete modules round out the TERMSERIES family. Their relays are integral, which makes them particularly vibration-proof. Due to the slim and, above all, flat design, they can be installed anywhere. And since they have the same contours as the tried-and-tested TERMSERIES, all the accessories of the series can be used – for cross-connections, for example. In this way, comprehensive complete solutions can be realised with the 100 % function-tested relay modules.

**Universal applicability**

Can be used in a wide range of applications thanks to different versions and a variety of input voltages. Multi-voltage input of the TERMSERIES with 24-230 V UC and 12-60 V UC available for the first time in an extremely compact design.

**High efficiency and user-friendliness**

PUSH IN connection technology and coloured pushers make wiring 75 % faster and considerably safer. Coloured accents for input voltages, easy-to-read part numbers, and integrated test taps facilitate maintenance.

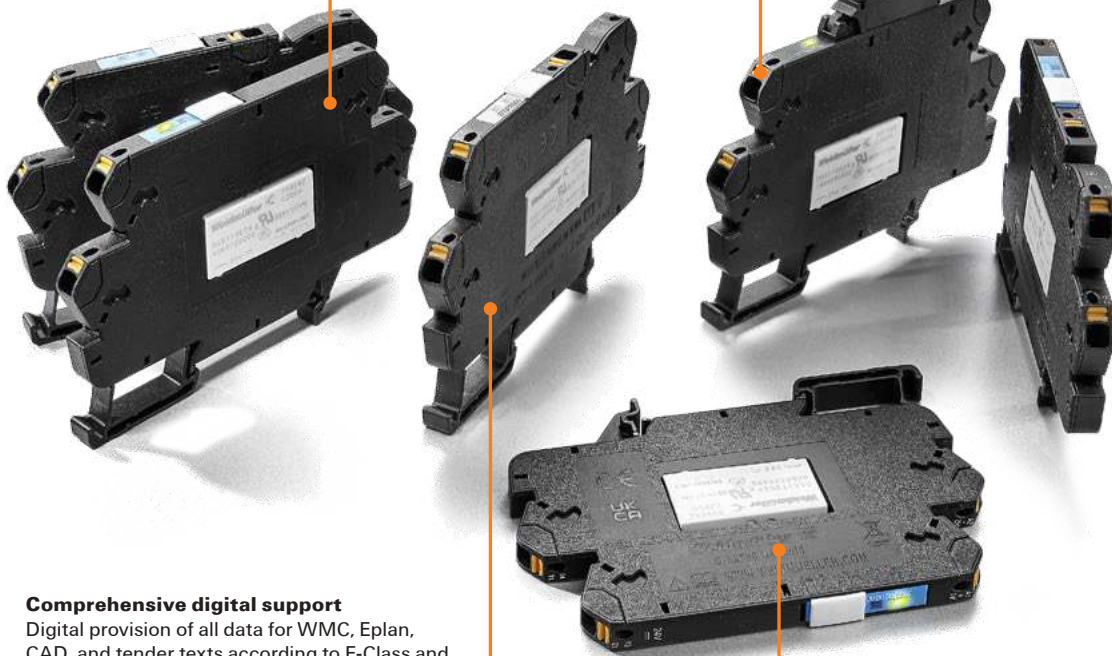
**Comprehensive digital support**

Digital provision of all data for WMC, Eplan, CAD, and tender texts according to E-Class and ETIM standards. Convenient data support via QR code on the side of the enclosure – with link to the data sheet. Support of digital twins.

**Perfect completion of the TERMSERIES**

With its closed design and depth of only 63 mm, TERMSERIES-compact completes the proven TERMSERIES. Accessories that can be used in common, contour uniformity, mirror-symmetrical design, and continuous cross-connection channels enable highly flexible solutions.

For more information, visit our website  
[www.weidmueller.com/termcompact](http://www.weidmueller.com/termcompact)

**1 CO contact**  
**AC / DC / UC coil**

- Ultra-compact 6.4 mm width
- AgNi contact
- PUSH IN connection



**B**

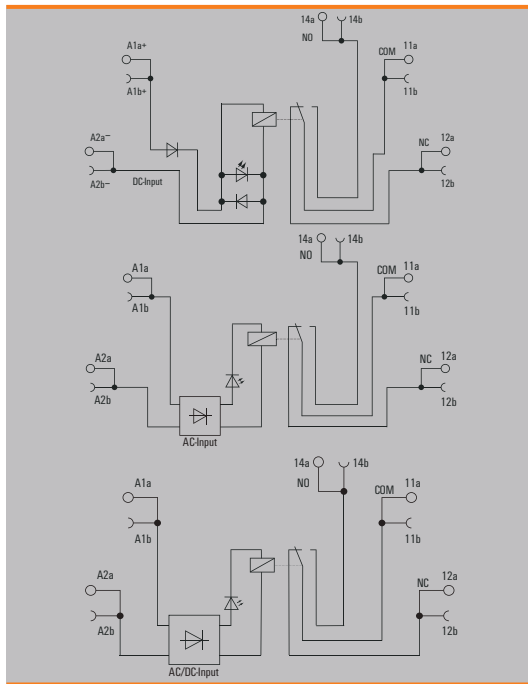

**Technical data**

Load side	
Rated switching voltage / Continuous current	250 V AC / 6 A
Max. switching voltage, AC	250 V
Inrush current	20 A / 20 ms
Min. switching power	1 mA @ 24 V, 10 mA @ 12 V, 100 mA @ 5 V
Contact type	1 CO contact (AgNi)
Mechanical service life	5 x 10 <sup>6</sup> switching cycles
Max. switching frequency at rated load	0.1 Hz
General data	
Ambient temperature (operational)	-40 °C...60 °C
Storage temperature	-40 °C...85 °C
Humidity	5-85% relative humidity, Tu = 40°C, without condensation
Approvals	CE; cULus; UKCA
Insulation coordinates	
Rated voltage	300 V
Impulse withstand voltage	6 kV (1.2/50 µs)
Dielectric strength for control side - load side	2.5 kV <sub>eff</sub>
Dielectric strength of neighbouring contacts	
Dielectric strength to mounting rail	4 kV <sub>eff</sub> / 1 Min.
Clearance and creepage distances for control side - load side	≥ 6 mm
Overvoltage category	III
Pollution degree	2
Dimensions	
Clamping range (nominal / min. / max.)	mm <sup>2</sup> 1.5 / 0.14 / 2.5
Depth x width x height	mm 62.5 / 6.4 / 89.4
Note	

**Applications**

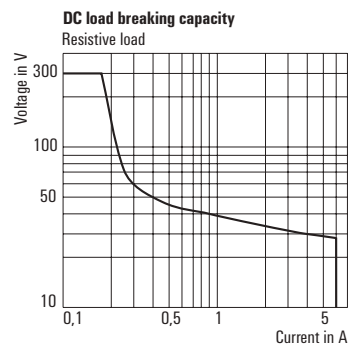
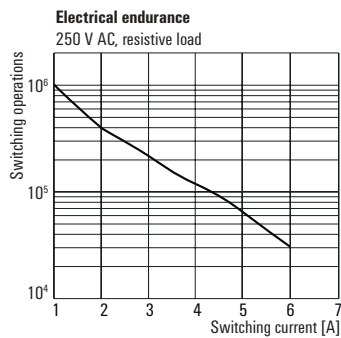

**1 CO contact**  
**AC / DC / UC coil**

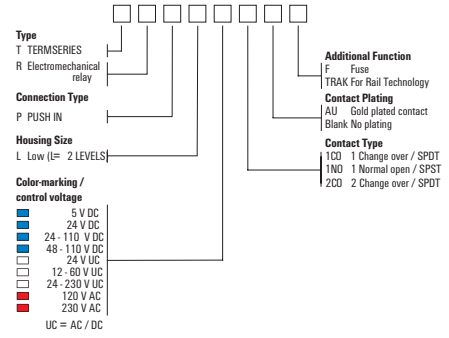

**Ordering data**

	5 V DC	24 V DC	24 V UC	120 V AC	230 V AC
<b>Control side</b>					
Rated control voltage	5 V DC ± 20 %	24 V DC ± 20 %	24 V UC ± 10 %	120 V AC ± 10 %	230 V AC ± 10 %
Rated current AC / DC	/ 34 mA	/ 11 mA	11.5 mA / 9.2 mA	6.8 mA /	7.1 mA /
Power rating	170 mW	264 mW	280 mVA / 220 mW	840 mVA	1.63 VA
Status indicator	Green LED	Green LED	Green LED	Green LED	Green LED
Protective circuit	Free-wheeling diode, Reverse polarity protection	Free-wheeling diode, Reverse polarity protection	Rectifier	Rectifier, RC element	Rectifier

Ordering data						
PUSH IN connection	Type	TRPL 5VDC 1CO	TRPL 24VDC 1CO	TRPL 24VUC 1CO	TRPL 120VAC 1CO	TRPL 230VAC 1CO
Order No.	Type	<b>2774030000</b>	<b>2773890000</b>	<b>2773970000</b>	<b>2773800000</b>	<b>2773830000</b>
Order No.	Type					
Note	Type					

1 CO contact

Multi-voltage input

- Ultra-compact 6.4 mm width
- AgNi contact
- PUSH IN connection
- Multi-voltage input: 24...230 V UC or 12...60 V UC in one module



B

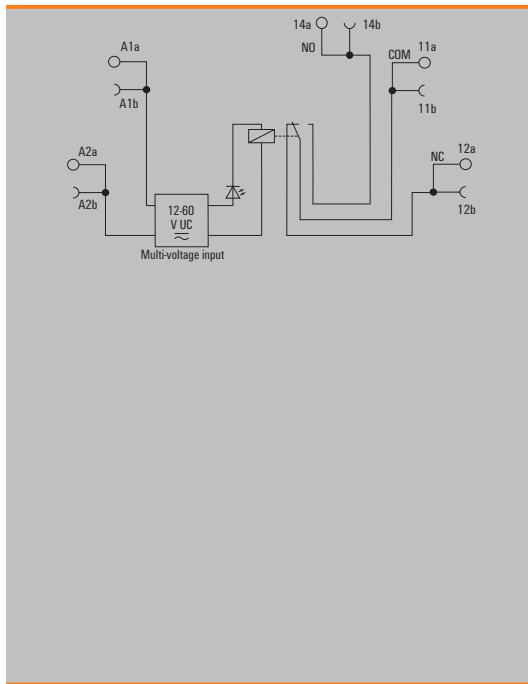

Technical data

Load side	
Rated switching voltage / Continuous current	250 V AC / 6 A
Max. switching voltage, AC	250 V
Inrush current	20 A / 20 ms
Min. switching power	1 mA @ 24 V, 10 mA @ 12 V, 100 mA @ 5 V
Contact type	1 CO contact (AgNi)
Mechanical service life	5 x 10 <sup>6</sup> switching cycles
Max. switching frequency at rated load	0.1 Hz
General data	
Ambient temperature (operational)	-40 °C...60 °C
Storage temperature	-40 °C...85 °C
Humidity	5-85% relative humidity, Tu = 40°C, without condensation
Approvals	CE; cULus; UKCA
Insulation coordinates	
Rated voltage	300 V
Impulse withstand voltage	6 kV (1.2/50 µs)
Dielectric strength for control side - load side	2.5 kV <sub>eff</sub>
Dielectric strength of neighbouring contacts	
Dielectric strength to mounting rail	4 kV <sub>eff</sub> / 1 Min.
Clearance and creepage distances for control side - load side	≥ 6 mm
Overvoltage category	III
Pollution degree	2
Dimensions	
Clamping range (nominal / min. / max.)	mm <sup>2</sup> 1.5 / 0.14 / 2.5
Depth x width x height	mm 62.5 / 6.4 / 89.4
Note	

Ordering data

Control side	12 - 60 V UC	24 - 230 V UC
Rated control voltage	12...60 V UC ± 10 %	24...230 V UC ± 10 %
Rated current AC / DC	41 mA @ 12 V AC, 10.2 mA @ 60 V AC / 20 mA @ 12 V DC, 5 mA @ 60 V DC	15.6 mA @ 24 V AC, 1.9 mA @ 230 V AC / 6.8 mA @ 24 V DC, 0.76 mA @ 230 V DC
Power rating	492 mVA @ 12 V AC, 612 mVA @ 60 V AC, 240 mW @ 12 V DC, 300 mW @ 60 V DC	163 mW @ 24 V DC, 175 mW @ 230 V DC, 374 mVA @ 24 V AC, 437 mVA @ 230 V AC
Status indicator	Green LED	Green LED
Protective circuit	Rectifier	Rectifier
Approvals	CE; cULus; UKCA	CE; cULus; UKCA

Ordering data			
PUSH IN connection	Type	TRPL 12-60VUC 1CO	TRPL 24-230VUC 1CO
	Order No.	2773770000	2773860000
	Type		
	Order No.		
Note			



**1 NO contact**  
**AC / DC / UC coil**

- Ultra-compact 6.4 mm width
- AgNi contact
- PUSH IN connection



**B**

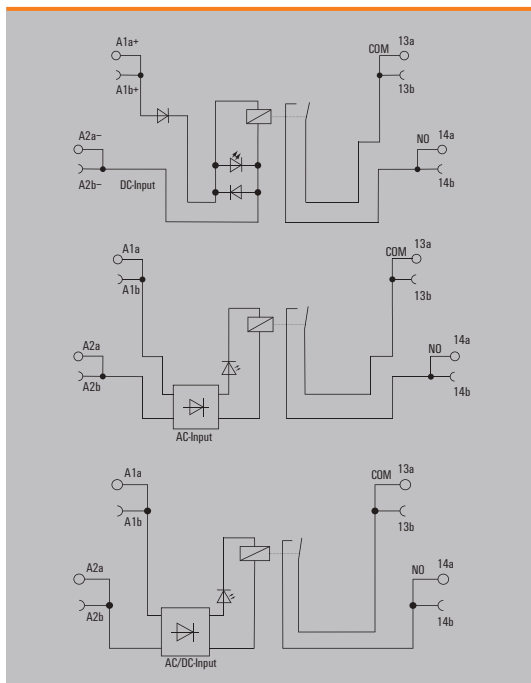

**Technical data**

Load side	
Rated switching voltage / Continuous current	250 V AC / 6 A
Max. switching voltage, AC	250 V
Inrush current	20 A / 20 ms
Min. switching power	1 mA @ 24 V, 10 mA @ 12 V, 100 mA @ 5 V
Contact type	1 NO contact (AgNi)
Mechanical service life	5 x 10 <sup>6</sup> switching cycles
Max. switching frequency at rated load	0.1 Hz
General data	
Ambient temperature (operational)	-40 °C...60 °C
Storage temperature	-40 °C...85 °C
Humidity	5-85% relative humidity, Tu = 40°C, without condensation
Approvals	CE; cULus; UKCA
Insulation coordinates	
Rated voltage	300 V
Impulse withstand voltage	6 kV (1.2/50 µs)
Dielectric strength for control side - load side	2.5 kV <sub>eff</sub>
Dielectric strength of neighbouring contacts	
Dielectric strength to mounting rail	4 kV <sub>eff</sub> / 1 Min.
Clearance and creepage distances for control side - load side	≥ 6 mm
Overvoltage category	III
Pollution degree	2
Dimensions	
Clamping range (nominal / min. / max.)	mm <sup>2</sup> 1.5 / 0.14 / 2.5
Depth x width x height	mm 62.5 / 6.4 / 89.4
Note	

**Applications**

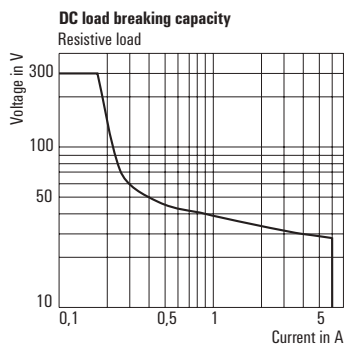
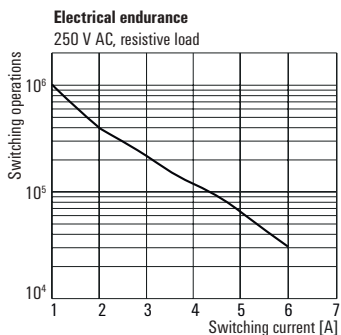

**1 NO contact  
AC / DC / UC coil**

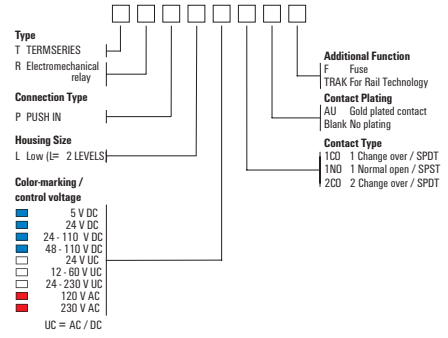

**Ordering data**

	5 V DC	24 V DC	24 V UC	120 V AC	230 V AC
<b>Control side</b>					
Rated control voltage	5 V DC $\pm$ 20 %	24 V DC $\pm$ 20 %	24 V UC $\pm$ 10 %	120 V AC $\pm$ 10 %	230 V AC $\pm$ 10 %
Rated current AC / DC	/ 34 mA	/ 11 mA	11.5 mA / 9.2 mA	6.8 mA /	7.1 mA /
Power rating	170 mW	264 mW	280 mVA / 220 mW	840 mVA	1.63 VA
Status indicator	Green LED	Green LED	Green LED	Green LED	Green LED
Protective circuit	Free-wheeling diode, Reverse polarity protection	Free-wheeling diode, Reverse polarity protection	Rectifier	Rectifier, RC element	Rectifier

Ordering data						
PUSH IN connection	Type	TRPL 5VDC 1NO	TRPL 24VDC 1NO	TRPL 24VUC 1NO	TRPL 120VAC 1NO	TRPL 230VAC 1NO
Order No.		<b>2774040000</b>	<b>2773920000</b>	<b>2773980000</b>	<b>2773810000</b>	<b>2773840000</b>
Type						
Order No.						
Note						

1 NO contact

Multi-voltage input

- Ultra-compact 6.4 mm width
- AgNi contact
- PUSH IN connection
- Multi-voltage input: 24...230 V UC or 12...60 V UC in one module



B

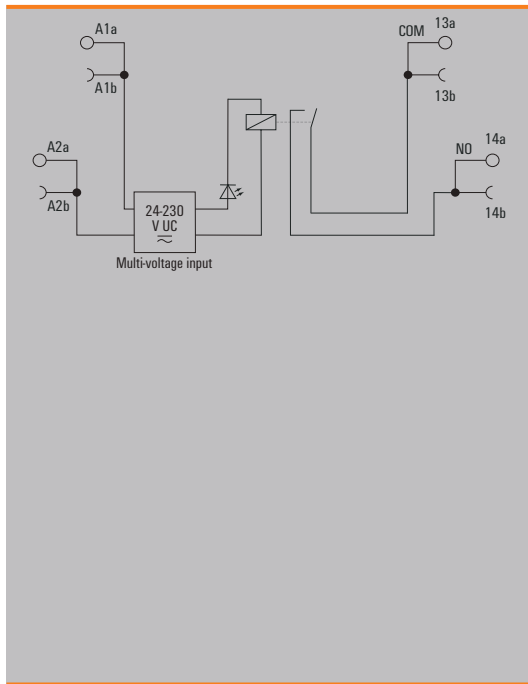

Technical data

Load side	
Rated switching voltage / Continuous current	250 V AC / 6 A
Max. switching voltage, AC	250 V
Inrush current	20 A / 20 ms
Min. switching power	1 mA @ 24 V, 10 mA @ 12 V, 100 mA @ 5 V
Contact type	1 1 NO contacts, NO contact (AgNi)
Mechanical service life	5 x 10 <sup>6</sup> switching cycles
Max. switching frequency at rated load	0.1 Hz
General data	
Ambient temperature (operational)	-40 °C...60 °C
Storage temperature	-40 °C...85 °C
Humidity	5-85% relative humidity, Tu = 40°C, without condensation
Approvals	CE; cULus; UKCA
Insulation coordinates	
Rated voltage	300 V
Impulse withstand voltage	6 kV (1.2/50 µs)
Dielectric strength for control side - load side	2.5 kV <sub>eff</sub>
Dielectric strength of neighbouring contacts	
Dielectric strength to mounting rail	4 kV <sub>eff</sub> / 1 Min.
Clearance and creepage distances for control side - load side	≥ 6 mm
Overvoltage category	III
Pollution degree	2
Dimensions	
Clamping range (nominal / min. / max.)	mm <sup>2</sup> 1.5 / 0.14 / 2.5
Depth x width x height	mm 62.5 / 6.4 / 89.4
Note	

Ordering data

Control side	12 - 60 V UC	24 - 230 V UC
Rated control voltage	12...60 V UC ± 10 %	24...230 V UC ± 10 %
Rated current AC / DC	41 mA @ 12 V AC, 10.2 mA @ 60 V AC / 20 mA @ 12 V DC, 5 mA @ 60 V DC	15.6 mA @ 24 V AC, 1.9 mA @ 230 V AC / 6.8 mA @ 24 V DC, 0.76 mA @ 230 V DC
Power rating	215 mW @ 12 V DC, 325 mW @ 60 V DC, 492 mVA @ 12 V AC, 612 mVA @ 60 V AC	158 mW @ 24 V DC, 175 mW @ 230 V DC, 374 mVA @ 24 V AC, 437 mVA @ 230 V AC
Status indicator	Green LED	Green LED
Protective circuit	Rectifier	Rectifier
Approvals	CE; cULus; UKCA	CE; cULus; UKCA

Ordering data			
PUSH IN connection	Type	TRPL 12-60VUC 1NO	TRPL 24-230VUC 1NO
	Order No.	2773780000	2773870000
	Type		
	Order No.		
Note			



**2 CO contact**  
**AC / DC / UC coil**

- Ultra-compact 12.8 mm width
- AgNi contact
- PUSH IN connection

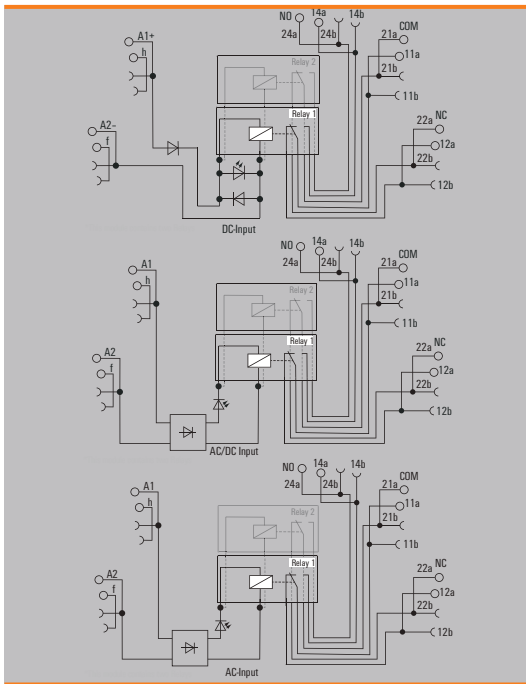

**Technical data**

Load side	
Rated switching voltage / Continuous current	250 V AC / 6 A
Max. switching voltage, AC	250 V
Inrush current	20 A / 20 ms
Min. switching power	1 mA @ 24 V, 10 mA @ 12 V, 100 mA / 5 V
Contact type	2 x 1 CO Contact (AgNi)
Mechanical service life	5 x 10 <sup>6</sup> switching cycles
Max. switching frequency at rated load	0.1 Hz
General data	
Ambient temperature (operational)	-40 °C...70 °C
Storage temperature	-40 °C...85 °C
Humidity	5-85% relative humidity, Tu = 40°C, without condensation
Approvals	
Insulation coordinates	
Rated voltage	300 V
Impulse withstand voltage	6 kV (1.2/50 µs)
Dielectric strength for control side - load side	4 kV <sub>eff</sub> / 1 min
Dielectric strength of neighbouring contacts	4 kV <sub>eff</sub> / 1 min
Dielectric strength to mounting rail	4 kV <sub>eff</sub> / 1 Min.
Clearance and creepage distances for control side - load side	≥ 6 mm
Overvoltage category	III
Pollution degree	2
Dimensions	
Clamping range (nominal / min. / max.)	mm <sup>2</sup> 1.5 / 0.14 / 2.5
Depth x width x height	mm 62.5 / 12.8 / 89.4
Note	

**2 CO contact**  
**AC / DC / UC coil**

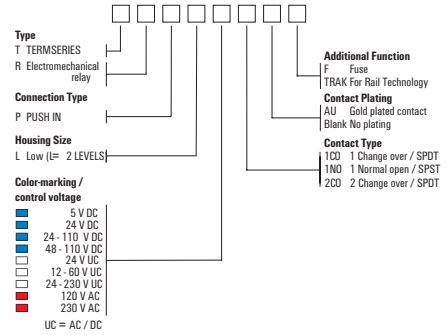

**Ordering data**

Control side	5 V DC	24 V DC	24 V UC	120 V AC	230 V AC
Rated control voltage	4 V...5 V...6 V DC ± 20 %	21.6 V...24 V...26.4 V DC ± 20 %	21.6 V...24 V...26.4 V AC/DC ± 10 %	108 V...120 V...132 V AC ± 10 %	207 V...230 V...253 V AC ± 10 %
Rated current AC / DC	/ 65 mA	/ 18 mA	26 mA / 16 mA	9 mA /	9 mA /
Power rating	320 mW	430 mW	0.6 VA / 0.35 W	1.03 VA	1.93 VA
Status indicator	Green LED	Green LED	Green LED	Green LED	Green LED
Protective circuit	Free-wheeling diode, Reverse polarity protection	Free-wheeling diode, Reverse polarity protection	Rectifier	Rectifier	Rectifier

Ordering data					
Type	TRPL 5VDC 2CO	TRPL 24VDC 2CO	TRPL 24VUC 2CO	TRPL 120VAC 2CO	TRPL 230VAC 2CO
Order No.	<b>2774050000</b>	<b>2773960000</b>	<b>2773990000</b>	<b>2773820000</b>	<b>2773850000</b>
Type					
Order No.					
Note					

**2 CO contact**

**Multi-voltage input**

- Ultra-compact 12.8 mm width
- AgNi contact
- PUSH IN connection
- Multi-voltage input: 24...230 V UC or 12...60 V UC in one module

**B**

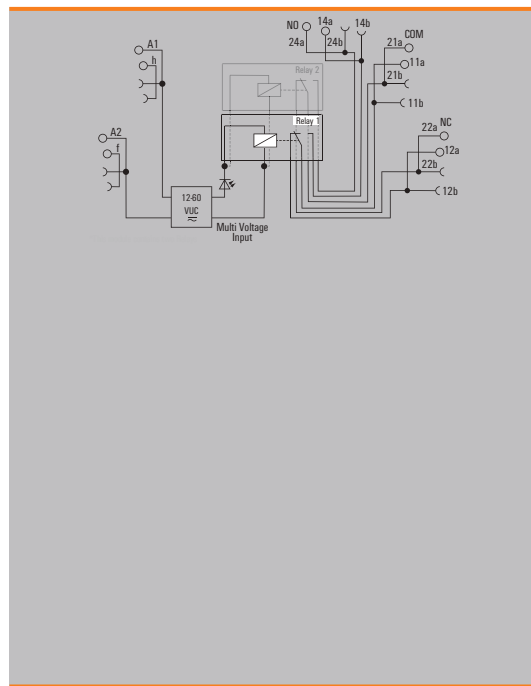

**Technical data**

Load side	
Rated switching voltage / Continuous current	250 V AC / 6 A
Max. switching voltage, AC	250 V
Inrush current	20 A / 20 ms
Min. switching power	1 mA @ 24 V, 10 mA @ 12 V, 100 mA @ 5 V
Contact type	2 x 1 CO Contact (AgNi)
Mechanical service life	5 x 10 <sup>6</sup> switching cycles
Max. switching frequency at rated load	0.1 Hz
General data	
Ambient temperature (operational)	-40 °C...70 °C
Storage temperature	-40 °C...85 °C
Humidity	5-85% relative humidity, Tu = 40°C, without condensation
Approvals	
Insulation coordinates	
Rated voltage	300 V
Impulse withstand voltage	6 kV (1.2/50 µs)
Dielectric strength for control side - load side	4 kV <sub>eff</sub> / 1 min
Dielectric strength of neighbouring contacts	4 kV <sub>eff</sub> / 1 min
Dielectric strength to mounting rail	4 kV <sub>eff</sub> / 1 Min.
Clearance and creepage distances for control side - load side	≥ 6 mm
Overvoltage category	III
Pollution degree	2
Dimensions	
<b>PUSH IN</b>	
Clamping range (nominal / min. / max.)	mm <sup>2</sup> 1.5 / 0.14 / 2.5
Depth x width x height	mm 62.5 / 12.8 / 89.4
Note	

**Ordering data**

Control side	
Rated control voltage	10.8...66 V AC/DC ± 10 %
Rated current AC / DC	57 mA @ 12V DC, 13 mA @ 60V DC
Power rating	680 mVA @ 24V DC, 780 mVA @ 60V DC
Status indicator	Green LED
Protective circuit	Rectifier
Approvals	

12 - 60 V UC	
Rated control voltage	10.8...66 V AC/DC ± 10 %
Rated current AC / DC	57 mA @ 12V DC, 13 mA @ 60V DC
Power rating	680 mVA @ 24V DC, 780 mVA @ 60V DC
Status indicator	Green LED
Protective circuit	Rectifier
Approvals	

24 - 230 V UC	
Rated control voltage	21.6...253 V AC/DC ± 10 %
Rated current AC / DC	19.3 mA @ 24 V AC, 2.5 mA @ 230 V AC / 9.6 mA @ 24V DC, 1.1 mA @ 230 V DC
Power rating	230 mW @ 24 V DC, 253 mVA @ 230V DC
Status indicator	Green LED
Protective circuit	Rectifier
Approvals	

Ordering data	
PUSH IN connection	Type
Order No.	Type
Order No.	Type
Note	

TRPL 12-60VUC 2CO
<b>2773790000</b>

TRPL 24-230VUC 2CO
<b>2773880000</b>



## TERMSERIES-compact with fuse carrier

### Combine switching and protection in one relay

#### B

Relays with integrated fuses are suitable for ensuring the reliable functioning of machines and systems and increasing their availability. In the event of faults, they switch off individual line paths to protect the rest of the system.

TERMSERIES-compact with fuse carrier enables simple and particularly efficient integration of fuses, as no additional terminal block with a fuse is required. This saves time during installation and space in the control cabinet. The fuse must be selected to match the connecting line, and the fuse can be changed while the module is installed. The complete module is 100 % function-tested and particularly vibration-resistant due to built-in relays.

#### Easy adaptability

The fuse holder is designed for fuses with standard dimensions of 5 x 20 mm. For protection against overcurrent, we offer suitable device protection fuses or miniature fuses from 100 mA to 6.3 A.

#### User-friendly fuse replacement

The swivelling or folding fuse link carrier allows fuses to be changed while installed. The visible separation distance facilitates inspection.

#### Low space requirement

TERMSERIES-compact combines two functions in one product. Due to the integrated fuse, no additional terminal blocks with fuses are required. This saves space in the control cabinet.



1 NO contact with fuse carrier

DC coil

- Ultra-compact 6.4 mm width
- AgNi contact
- PUSH IN connection
- With fuse carrier

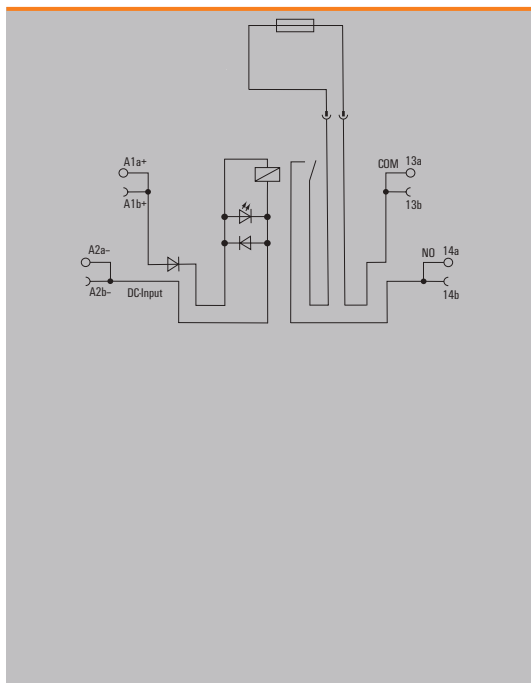

Technical data

Load side	
Rated switching voltage / Continuous current	250 V AC / 6 A
Max. switching voltage, AC	250 V
Inrush current	20 A / 20 ms
Min. switching power	1 mA @ 24 V, 10 mA @ 12 V, 100 mA @ 5 V
Contact type	1 NO contact (AgNi)
Mechanical service life	5 x 10 <sup>6</sup> switching cycles
Max. switching frequency at rated load	0.1 Hz
General data	
Ambient temperature (operational)	-40 °C...60 °C
Storage temperature	-40 °C...85 °C
Humidity	5-85% relative humidity, Tu = 40°C, without condensation
Approvals	CE; cURus; UKCA
Insulation coordinates	
Rated voltage	300 V
Impulse withstand voltage	6 kV (1.2/50 µs)
Dielectric strength for control side - load side	2.5 kV <sub>eff</sub>
Dielectric strength of neighbouring contacts	
Dielectric strength to mounting rail	4 kV <sub>eff</sub> / 1 Min.
Clearance and creepage distances for control side - load side	≥ 6 mm
Overvoltage category	III
Pollution degree	2
Dimensions	
Clamping range (nominal / min. / max.)	mm <sup>2</sup> 1.5 / 0.14 / 2.5
Depth x width x height	mm 90.9 / 6.4 / 89.4
Note	

Ordering data

Control side	24 V DC
Rated control voltage	24 V DC ± 20 %
Rated current AC / DC	/ 11 mA
Power rating	264 mW
Status indicator	Green LED
Protective circuit	Free-wheeling diode, Reverse polarity protection
Approvals	CE; cURus; UKCA

Ordering data	
PUSH IN connection	Type TRPL 24VDC 1NO F
Order No.	2773930000
Order No.	
Note	

## TERMSERIES-compact TRAK: Highly vibration-resistant universal relays

### Switch reliably in extreme environments

#### B

Trains and railway lines are often subject to extreme conditions. Electronic components have to withstand strong vibrations, temperature fluctuations and the effects of the weather. In addition, there are high requirements in terms of passenger safety and fire protection.

The ultra-compact TERMSERIES-compact TRAK complete modules comply with the strict standards of the railway industry. Their relays are permanently installed, which makes them particularly vibration-proof. They operate reliably in a temperature range of -40 to +70 °C and are protected against condensation. Typical railway voltage fluctuations and interruptions are tolerated without functional failure. Thanks to their slim, flat design, they can be installed anywhere. And since their contours are identical to those of the TERMSERIES, accessories of the series can be used. This means that extremely robust solutions can be realised. This means that extremely robust solutions can be realised - even outside the railway industry.

#### TERMSERIES-compact TRAK

- Developed according to the strict railway standards EN 50155, EN 61373 and EN 45545-2
- Resistant to voltage and temperature fluctuations
- Insensitive to shocks and vibrations



**Extremely robust and reliable**

TERMSERIES-compact TRAK is vibration-resistant according to EN 61373 (category 1 class B) and tolerates voltage fluctuations of -30 to +25 % as well as voltage interruptions in the input of up to 10 ms. The temperature resistance of -40 to +70 °C is even higher than required by EN 50155 (-25 to +70 °C).

**Particularly flexible and user-friendly**

Continuous cross-connection channels enable flexible and particularly time-saving wiring. The bright status LED enables a quick visual function check.

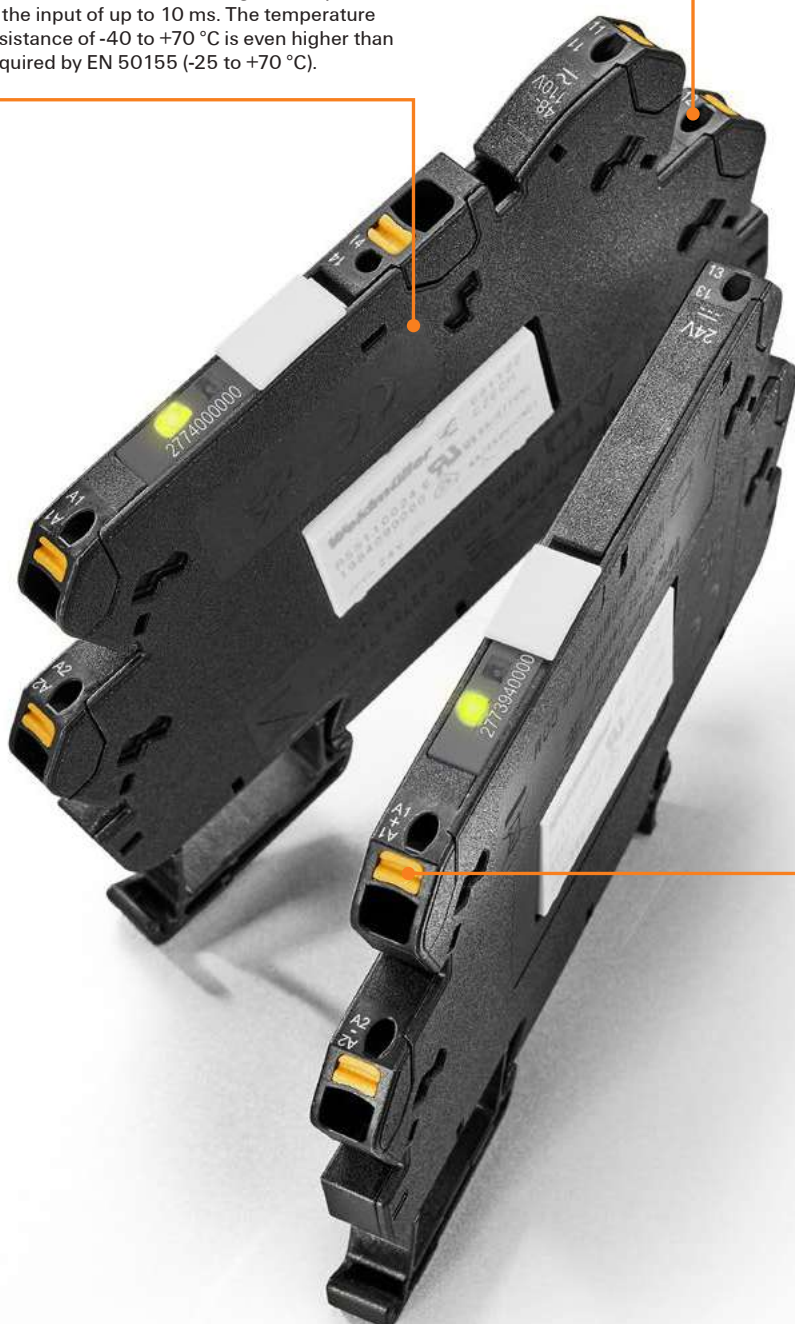

**Highly efficient and safe**

PUSH IN connection technology makes wiring considerably safer and 75 % faster. Easy-to-read part numbers as well as integrated test taps on each level facilitate maintenance.

TRAK with 1 CO contact



B

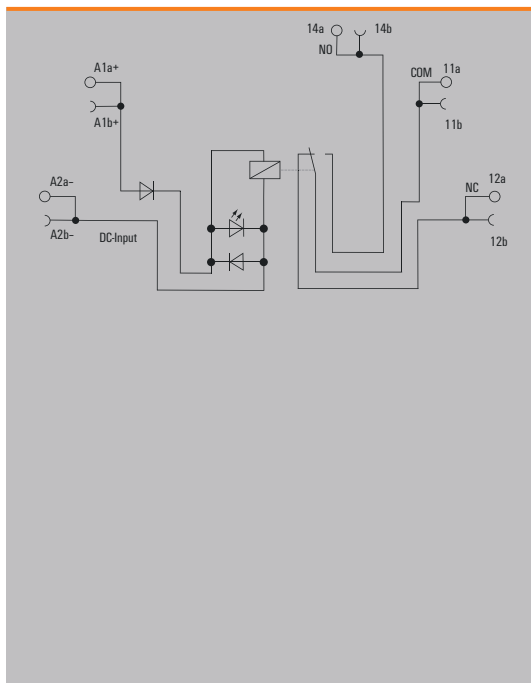

Technical data

Load side	
Rated switching voltage / Continuous current	250 V AC / 6 A
Max. switching voltage, AC	250 V
Inrush current	20 A / 20 ms
Min. switching power	1 mA @ 24 V, 10 mA @ 12 V, 100 mA @ 5 V
Contact type	1 CO contact (AgSnO2)
Mechanical service life	10 x 10 <sup>6</sup> switching cycles
Max. switching frequency at rated load	0.1 Hz
General data	
Ambient temperature (operational)	-40 °C...70 °C
Storage temperature	-40 °C...85 °C
Humidity	95 % for 30 days, minimal condensation to EN 50155
Approvals	CE; UKCA
Insulation coordinates	
Rated voltage	300 V
Impulse withstand voltage	6 kV (1.2/50 µs)
Dielectric strength for control side - load side	2.5 kV <sub>eff</sub>
Dielectric strength of neighbouring contacts	
Dielectric strength to mounting rail	4 kV <sub>eff</sub> / 1 Min.
Clearance and creepage distances for control side - load side	≥ 6 mm
Overvoltage category	III
Pollution degree	2
Dimensions	
Clamping range (nominal / min. / max.)	mm <sup>2</sup> 1.5 / 0.14 / 2.5
Depth x width x height	mm 62.5 / 6.4 / 89.4
Note	

Applications

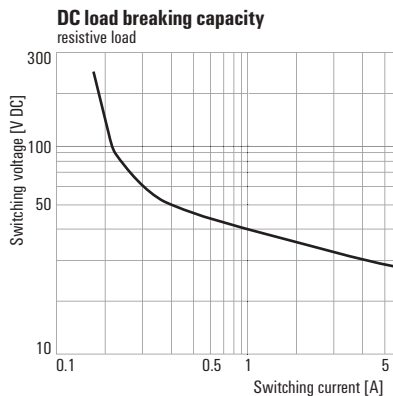
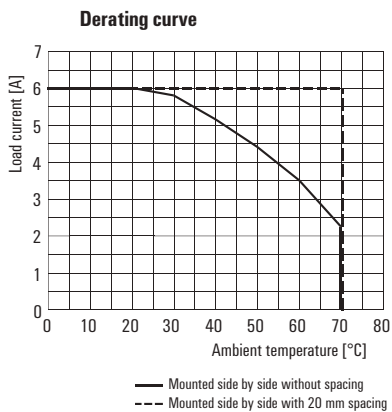

TRAK with 1 CO contact

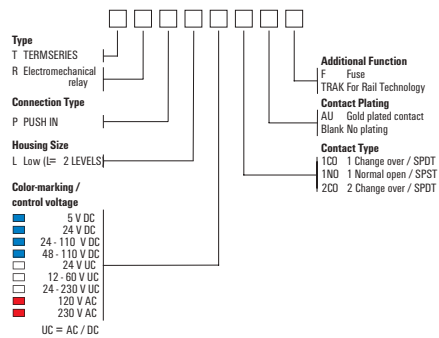

Ordering data

	24 V DC	48-110 V DC
<b>Control side</b>		
Rated control voltage	24 V DC + 25 % / - 30 %	48...110 V DC + 25 % / - 30 %
Rated current AC / DC	/ 16 mA	/ 2.4 mA @ 48 V DC, 3.2 mA @ 110 V DC
Power rating	384 mW	115 mW @ 48 V DC, 352 mW @ 110 V DC
Status indicator	Green LED	Green LED
Protective circuit	Suppressor diode, Free-wheeling diode	Suppressor diode, Free-wheeling diode
Approvals	CE; UKCA	CE; UKCA

Ordering data		
PUSH IN connection	Type	TRPL 24VDC 1CO TRAK
	Order No.	<b>2773910000</b>
	Type	TRPL 48-110VDC 1CO TRAK
	Order No.	<b>2774010000</b>
Note		

TRAK with 1 CO contact with hard gold-plated contacts



B

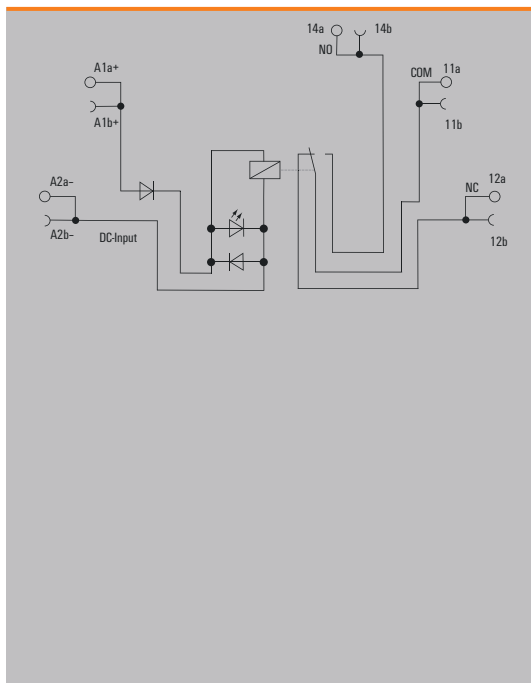

Technical data

Load side	
Rated switching voltage / Continuous current	250 V AC / 6 A
Max. switching voltage, AC	250 V
Inrush current	20 A / 20 ms
Min. switching power	50 mW
Contact type	1 CO contact (Au (Gold), AgSnO2)
Mechanical service life	10 x 10 <sup>6</sup> switching cycles
Max. switching frequency at rated load	0.1 Hz
General data	
Ambient temperature (operational)	-40 °C...70 °C
Storage temperature	-40 °C...85 °C
Humidity	95 % for 30 days, minimal condensation to EN 50155
Approvals	CE; UKCA
Insulation coordinates	
Rated voltage	300 V
Impulse withstand voltage	6 kV (1.2/50 µs)
Dielectric strength for control side - load side	2.5 kV <sub>eff</sub>
Dielectric strength of neighbouring contacts	
Dielectric strength to mounting rail	4 kV <sub>eff</sub> / 1 Min.
Clearance and creepage distances for control side - load side	≥ 6 mm
Overvoltage category	III
Pollution degree	2
Dimensions	
Clamping range (nominal / min. / max.)	mm <sup>2</sup> 1.5 / 0.14 / 2.5
Depth x width x height	mm 62.5 / 6.4 / 89.4
Note	

Applications

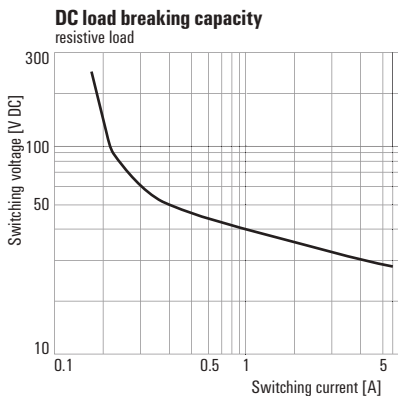
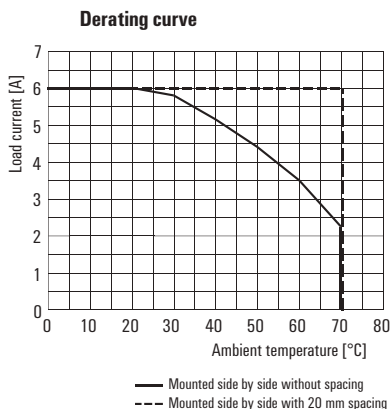

TRAK with 1 CO contact with hard gold-plated contacts

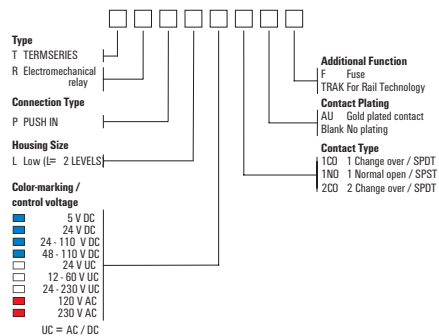

Ordering data

	24 V DC	48-110 V DC
<b>Control side</b>		
Rated control voltage	24 V DC + 25 % / - 30 %	48...110 V DC + 25 % / - 30 %
Rated current AC / DC	/ 16 mA	/ 2.4 mA @ 48 V DC, 3.2 mA @ 110 V DC
Power rating	384 mW	115 mW @ 48 V DC, 352 mW @ 110 V DC
Status indicator	Green LED	Green LED
Protective circuit	Free-wheeling diode, Suppressor diode	Suppressor diode, Free-wheeling diode
Approvals	CE; UKCA	CE; UKCA

Ordering data		
PUSH IN connection	Type	TRPL 24VDC 1CO AU TRAK
Order No.		<b>2773900000</b>
	Type	TRPL 48-110VDC 1CO AU TRAK
Order No.		<b>2774000000</b>
Note		

TRAK with 1 NO contact



B

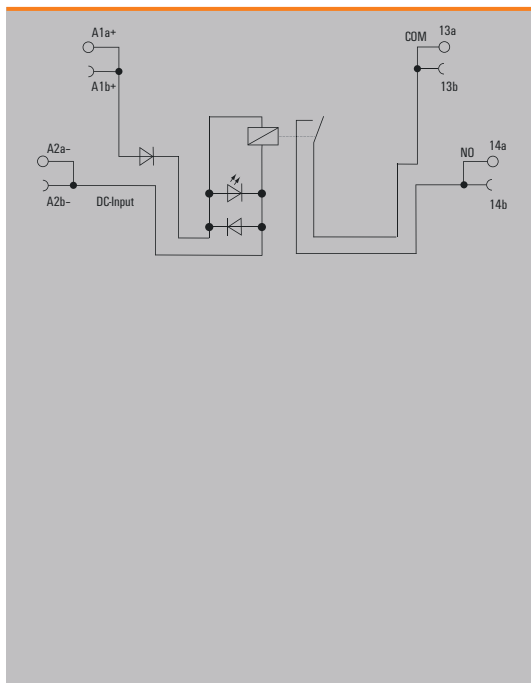

Technical data

Load side	
Rated switching voltage / Continuous current	250 V AC / 6 A
Max. switching voltage, AC	250 V
Inrush current	20 A / 20 ms
Min. switching power	1 mA @ 24 V, 10 mA @ 12 V, 100 mA @ 5 V
Contact type	1 NO contact (AgSnO2)
Mechanical service life	10 x 10 <sup>6</sup> switching cycles
Max. switching frequency at rated load	0.1 Hz
General data	
Ambient temperature (operational)	-40 °C...70 °C
Storage temperature	-40 °C...85 °C
Humidity	95 % for 30 days, minimal condensation to EN 50155
Approvals	CE; UKCA
Insulation coordinates	
Rated voltage	300 V
Impulse withstand voltage	6 kV (1.2/50 µs)
Dielectric strength for control side - load side	2.5 kV <sub>eff</sub>
Dielectric strength of neighbouring contacts	
Dielectric strength to mounting rail	4 kV <sub>eff</sub> / 1 Min.
Clearance and creepage distances for control side - load side	≥ 6 mm
Overvoltage category	III
Pollution degree	2
Dimensions	
Clamping range (nominal / min. / max.)	mm <sup>2</sup> 1.5 / 0.14 / 2.5
Depth x width x height	mm 62.5 / 6.4 / 89.4
Note	

Applications

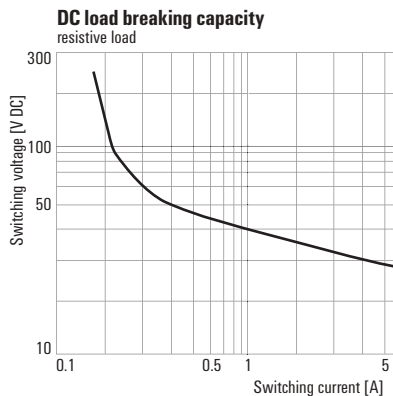
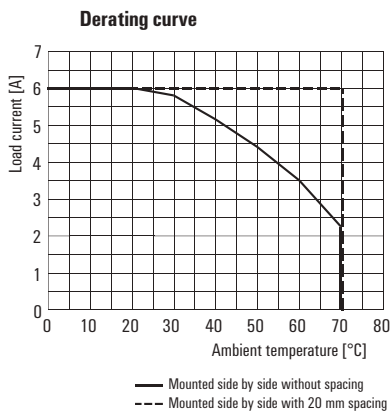

TRAK with 1 NO contact

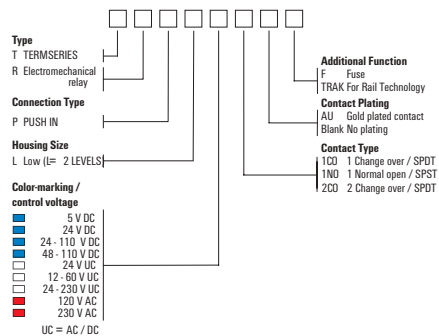

Ordering data

	24 V DC	48-110 V DC
<b>Control side</b>		
Rated control voltage	24 V DC + 25 % / - 30 %	48...110 V DC + 25 % / - 30 %
Rated current AC / DC	/ 16 mA	/ 2.4 mA @ 48 V DC, 3.2 mA @ 110 V DC
Power rating	384 mW	115 mW @ 48 V DC, 352 mW @ 110 V DC
Status indicator	Green LED	Green LED
Protective circuit	Suppressor diode, Free-wheeling diode	Suppressor diode, Free-wheeling diode
Approvals	CE; UKCA	CE; UKCA

Ordering data		
PUSH IN connection	Type	TRPL 24VDC 1NO TRAK
Order No.	Type	TRPL 48-110VDC 1NO TRAK
	Order No.	
<b>Note</b>		

TRAK-Version



B

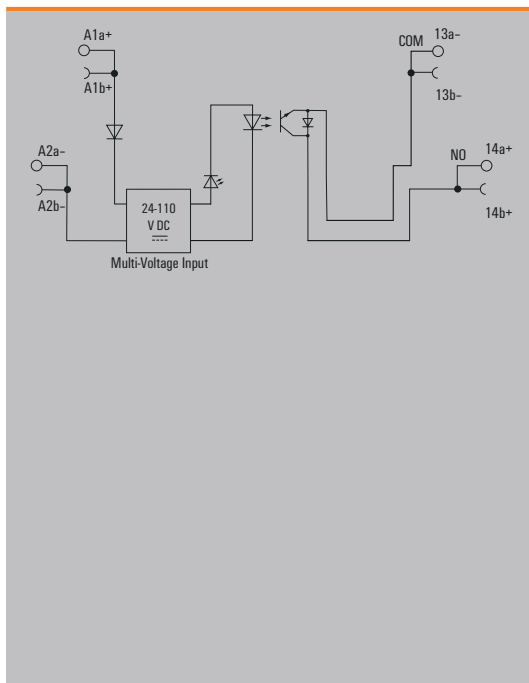

Technical data

Load side	
Rated switching voltage / Continuous current	5...110 V DC / 250 mA
Max. switching voltage, AC	
Inrush current	3.4 mA @ 24 V DC, 11.4 mA @ 110 V DC
Min. switching power	
Contact type	NO contact
Mechanical service life	
Max. switching frequency at rated load	0.1 Hz
General data	
Ambient temperature (operational)	-40 °C...70 °C
Storage temperature	-40 °C...85 °C
Humidity	5-85% relative humidity, Tu = 40°C, without condensation
Approvals	CE; UKCA
Insulation coordinates	
Rated voltage	
Impulse withstand voltage	6 kV (1.2/50 µs)
Dielectric strength for control side - load side	2.5 kV <sub>eff</sub>
Dielectric strength of neighbouring contacts	
Dielectric strength to mounting rail	4 kV <sub>eff</sub> / 1 Min.
Clearance and creepage distances for control side - load side	8 mm
Overvoltage category	III
Pollution degree	2
Dimensions	
Clamping range (nominal / min. / max.)	mm <sup>2</sup> 1.5 / 0.14 / 2.5
Depth x width x height	mm 62.5 / 6.4 / 89.4
Note	

Applications

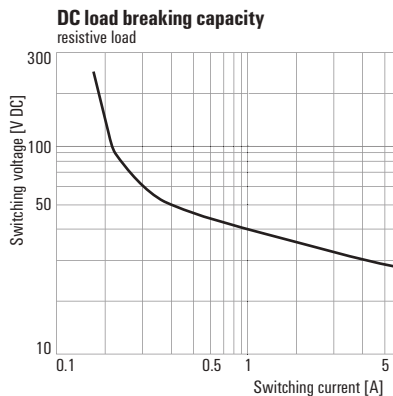
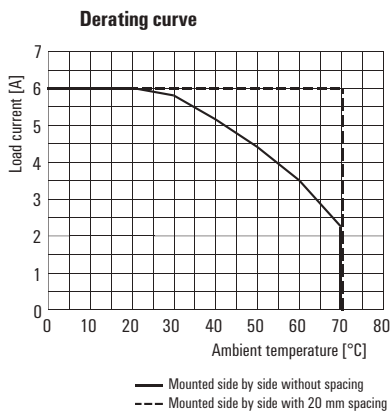

TRAK-Version

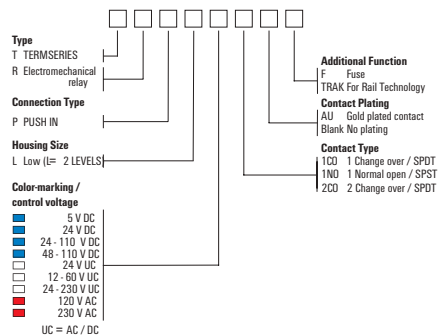

Ordering data

24-110 V DC	
<b>Control side</b>	
Rated control voltage	24...110 V DC + 25 % / - 30 %
Rated current AC / DC	/ 1.9 mA @ 24 V DC, 3.2 mA @ 110 V DC
Power rating	46 mW @ 24 V DC, 352 mW @ 110 V DC
Status indicator	Green LED
Protective circuit	Reverse polarity protection
Approvals	CE; UKCA

Ordering data	
PUSH IN connection	Type
Order No.	TDPL 24-110VDC 5-110VDC0.25A TRAK
Type	2773600000
Order No.	
<b>Note</b>	

Universal range

B

# TERMSERIES

## The all-rounders in a terminal block format

### B

TERMSERIES relay modules and solid-state relays are real all-rounders in the extensive Klippon® Relay portfolio. The pluggable modules are available in many variants and can be exchanged quickly and easily – they are ideal for use in modular systems. Their large illuminated ejection lever also serves as a status LED with integrated holder for markers, making maintenance easier. TERMSERIES products are particularly space-saving and are available in widths from 6.4 mm. Besides their versatility, they convince through their extensive accessories and unlimited cross-connection possibilities.

TERMSERIES products are available for special loads, for C1D2 applications, with timer functions or with positively-driven contacts. Special variants for connecting actuators – e.g. solenoid valves or contactors – are also available. The range of applications is extended by various connection systems such as PUSH IN and screw connection. And with the unique multi-voltage input, you can optimise your wiring and simplify your retrofitting processes. All products are of course approved according to the current international standards such as cULus and DNV.

Our TERMSERIES variants for special loads are assembled with optimised contacts. Their arrangement and material selection were adapted to suit the high loads in the industrial sector. Whether in machinery and plant engineering, robotics, wind energy or shipbuilding: With TERMSERIES products you can reliably and permanently switch industrial loads and reduce your operating costs.

**Space-saving design**

The slim design with compact widths from 6.4 mm provides noticeable space savings in the panel.

**Unique multi-voltage input**

The input allows controlling with voltages from 24 to 230 V AC/DC in one device. This reduces the number of required part numbers and makes retrofitting easier.

**Ergonomic design**

The high-quality design without sharp edges reduces the risk of injury. All markings are readable, no matter which position the components are installed in, which makes work easier.

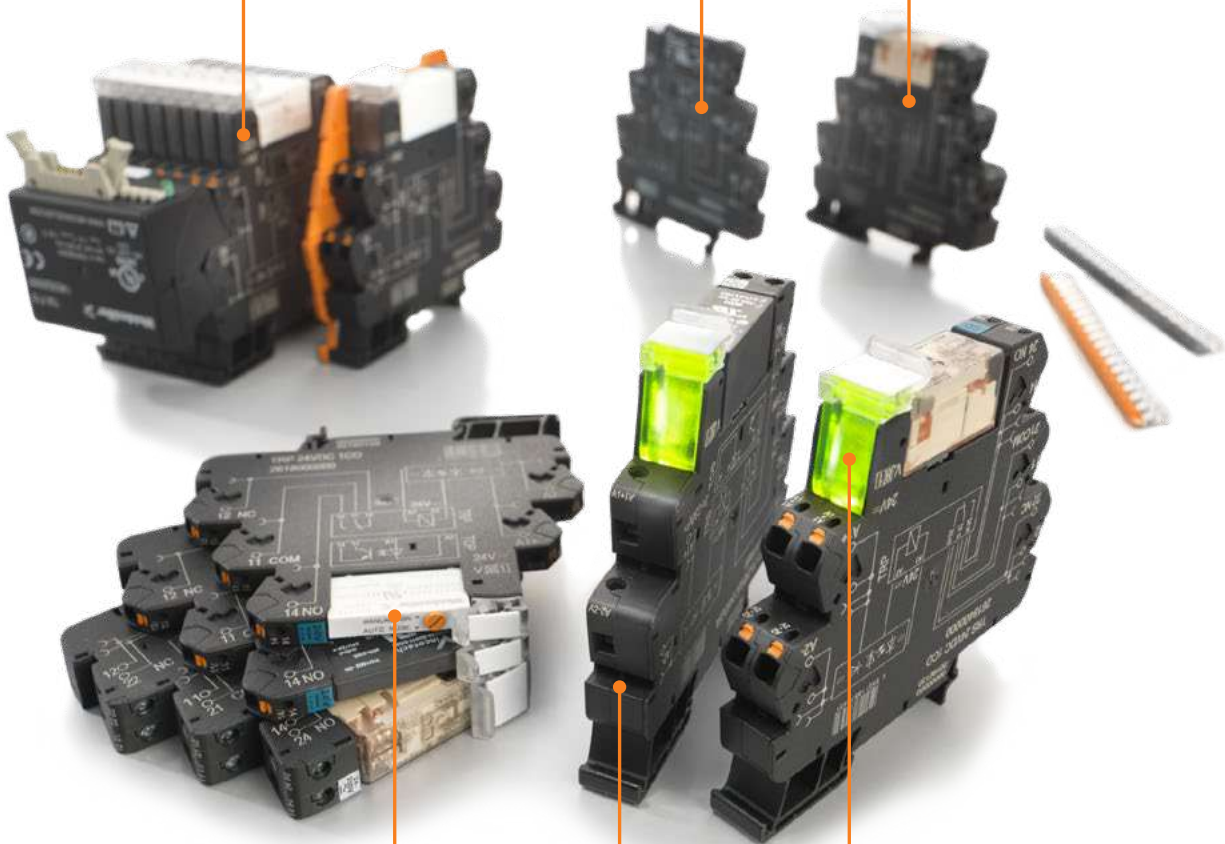
**Lockable test button**

The test button enables easy simulation of digital input and output signals. For protection against maloperation, it can only be locked with a screwdriver.

**Multi-functional ejector lever**

The ejector lever allows the plugged-in relays to be replaced easily. It is also used to hold markers and has a status LED that illuminates the entire ejector.

**Continuous cross-connectors**

The continuous cross-connection channels increase flexibility and save wiring time at every level.

For more information,  
visit our website  
[www.weidmueller.com/term](http://www.weidmueller.com/term)

**1 CO contact**  
**AC/DC/UC coil**

- Space-saving, only 6.4 mm wide
- AgNi contact
- PUSH IN and screw connection

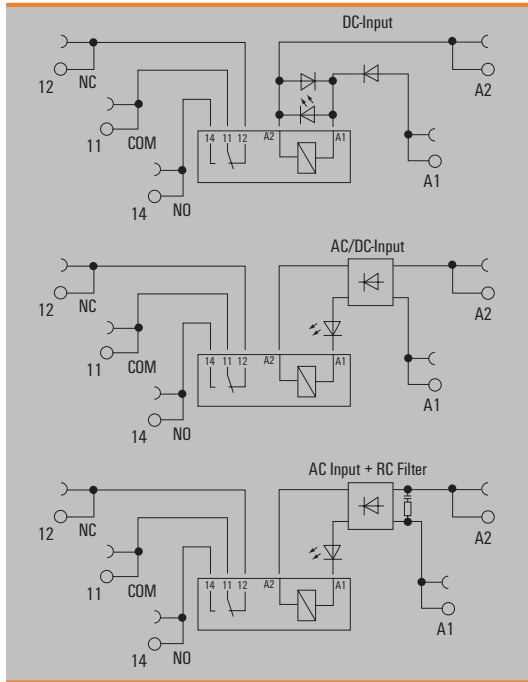
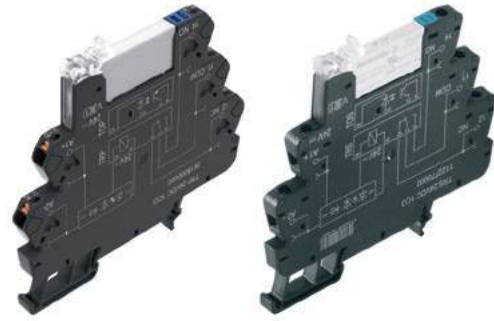

**Technical data**

Load side	
Rated switching voltage / Continuous current	250 V AC / 6 A
Max. switching voltage, AC	250 V
Inrush current	20 A / 20 ms
Min. switching power	1 mA @ 24 V, 10 mA @ 12 V, 100 mA @ 5 V
Contact type	1 CO contact (AgNi)
Mechanical service life	5 x 10 <sup>6</sup> switching cycles
Max. switching frequency at rated load	0.1 Hz

General data	
Ambient temperature (operational)	-40 °C...60 °C
Storage temperature	-40 °C...85 °C
Humidity	5-95% relative humidity, T <sub>90</sub> = 40°C, without condensation
Approvals	CE; cULus; DETNORVER; UKCA

Insulation coordinates	
Rated voltage	300 V
Impulse withstand voltage	6 kV (1.2/50 µs)
Dielectric strength for control side - load side	4 kV <sub>eff</sub> / 1 Min.
Dielectric strength of neighbouring contacts	
Dielectric strength to mounting rail	4 kV <sub>eff</sub> / 1 Min.
Clearance and creepage distances for control side - load side	≥ 6 mm
Overvoltage category	III
Pollution degree	2

Dimensions	PUSH IN	Screw connection
Clamping range (nominal / min. / max.)	mm <sup>2</sup> 1.5 / 0.14 / 2.5	1.5 / 0.14 / 2.5
Depth x width x height	mm 87.8 / 6.4 / 89.4	87.8 / 6.4 / 89.6

**Note** Accessories and dimensional drawings: refer to the TERMSERIES Accessories page. Further approvals and technical data can be found at [eshop.weidmueller.com](http://eshop.weidmueller.com)

**Applications**

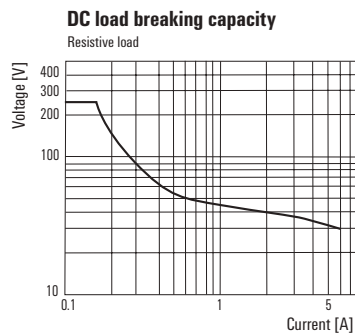
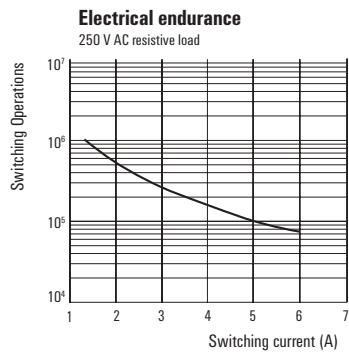

**1 CO contact**  
**AC/DC/UC coil**

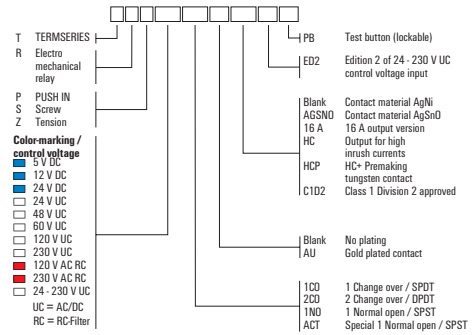

**Ordering data**

	5 V DC	12 V DC	24 V DC	24 V UC	48 V UC
<b>Control side</b>					
Rated control voltage	5 V DC ± 20 %	12 V DC ± 20 %	24 V DC ± 20 %	24 V UC ± 10 %	48 V UC ± 10 %
Rated current AC / DC	/ 33 mA	/ 18 mA	/ 11.5 mA	11.7 mA / 6.4 mA	8 mA / 7 mA
Power rating	170 mW	210 mW	280 mW	270 mVA / 154 mW	340 mW / 0.4 VA
Status indicator	Green LED	Green LED	Green LED	Green LED	Green LED
Protective circuit	Free-wheeling diode, Reverse polarity protection	Free-wheeling diode, Reverse polarity protection	Free-wheeling diode, Reverse polarity protection	Rectifier	Rectifier

Ordering data					
PUSH IN connection Type	TRP 5VDC 1C0	TRP 12VDC 1C0	TRP 24VDC 1C0	TRP 24VUC 1C0	TRP 48VUC 1C0
Order No.	<b>2614830000</b>	<b>2618180000</b>	<b>2618000000</b>	<b>2618220000</b>	<b>2618240000</b>
Screw connection Type	TRS 5VDC 1C0	TRS 12VDC 1C0	TRS 24VDC 1C0	TRS 24VUC 1C0	TRS 48VUC 1C0
Order No.	<b>1122740000</b>	<b>1122750000</b>	<b>1122770000</b>	<b>1122780000</b>	<b>1122790000</b>
Note					

**Ordering data**

	60 V UC	120 V UC	230 V UC	120 V AC RC	230 V AC RC
<b>Control side</b>					
Rated control voltage	60 V UC ± 10 %	120 V UC ± 10 %	230 V UC ± 10 %	120 V AC ± 10 %	230 V AC ± 10 %
Rated current AC / DC	4,8 mA / 2,8 mA	4 mA / 3,5 mA	3,5 mA / 2,9 mA	7 mA /	8,5 mA /
Power rating	170 mW, 290 mVA	0,48 VA, 420 mW	670 mW, 805 mVA	840 mVA	2 VA
Status indicator	Green LED	Green LED	Green LED	Green LED	Green LED
Protective circuit	Rectifier	Rectifier	Rectifier	Rectifier, RC element	Rectifier, RC element

Ordering data					
PUSH IN connection Type	TRP 60VUC 1C0	TRP 120VUC 1C0	TRP 230VUC 1C0	TRP 120VAC RC 1C0	TRP 230VAC RC 1C0
Order No.	<b>2618140000</b>	<b>2618010000</b>	<b>2618050000</b>	<b>2618150000</b>	<b>2618200000</b>
Screw connection Type	TRS 60VUC 1C0	TRS 120VUC 1C0	TRS 230VUC 1C0	TRS 120VAC RC 1C0	TRS 230VAC RC 1C0
Order No.	<b>1122800000</b>	<b>1122810000</b>	<b>1122820000</b>	<b>1122830000</b>	<b>1122840000</b>
Note					

1 CO contact with hard gold-plated contacts

AC/DC/UC coil

- Space saving, just 6.4 mm modular width
- AgNi contact with gold plating
- PUSH IN and screw connection

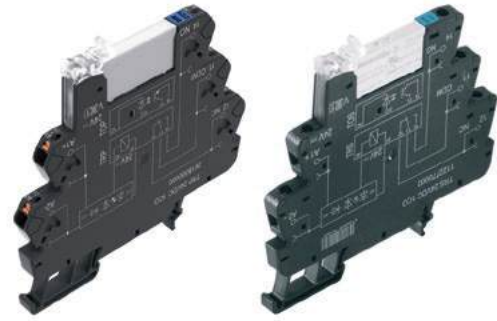

B

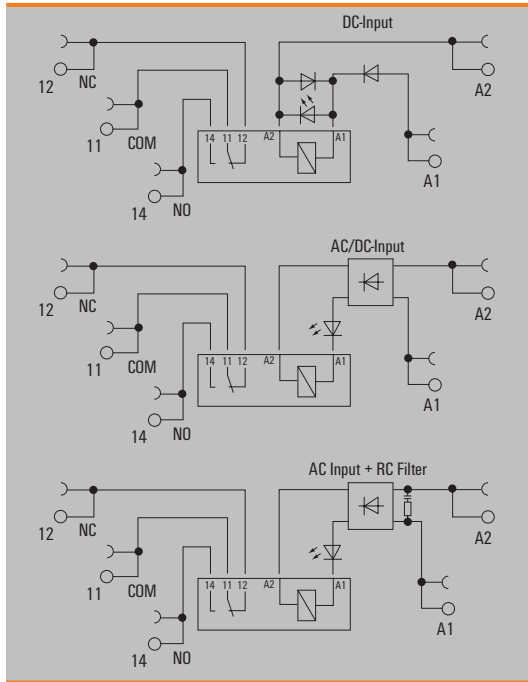

Technical data

Load side	
Rated switching voltage / Continuous current	250 V AC / 6 A
Max. switching voltage, AC	250 V
Inrush current	20 A / 20 ms
Min. switching power	1 mA @ 1 V
Contact type	1 CO contact (AgNi gold-plated)
Mechanical service life	5 x 10 <sup>6</sup> switching cycles
Max. switching frequency at rated load	0.1 Hz
General data	
Ambient temperature (operational)	-40 °C...60 °C
Storage temperature	-40 °C...85 °C
Humidity	5-95% relative humidity, T <sub>90</sub> = 40°C, without condensation
Approvals	CE; cULus; DETNORVER; UKCA
Insulation coordinates	
Rated voltage	300 V
Impulse withstand voltage	6 kV (1.2/50 µs)
Dielectric strength for control side - load side	4 kV <sub>eff</sub> / 1 Min.
Dielectric strength of neighbouring contacts	
Dielectric strength to mounting rail	4 kV <sub>eff</sub> / 1 Min.
Clearance and creepage distances for control side - load side	≥ 6 mm
Overvoltage category	III
Pollution degree	2
Dimensions	
Clamping range (nominal / min. / max.)	mm <sup>2</sup> 1.5 / 0.14 / 2.5
Depth x width x height	mm 87.8 / 6.4 / 89.4
	mm 87.8 / 6.4 / 89.6
Note	
Accessories and dimensional drawings: refer to the TERMSERIES Accessories page. Further approvals and technical data can be found at <a href="http://eshop.weidmueller.com">eshop.weidmueller.com</a>	

Applications

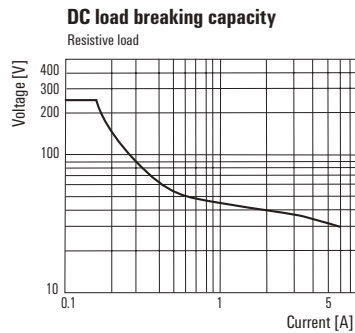
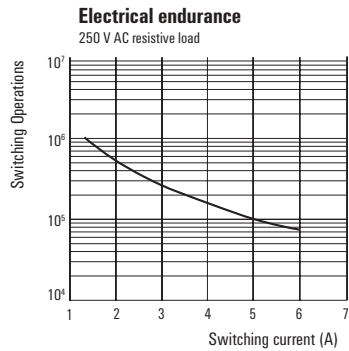

**1 CO contact with hard gold-plated contacts**  
**AC/DC/UC coil**

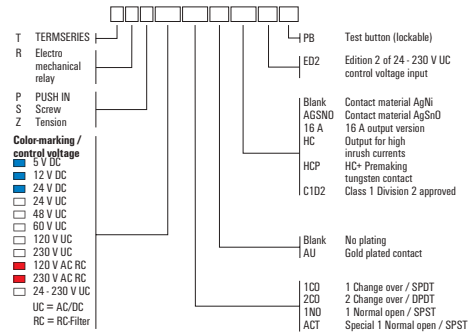

**Ordering data**

Control side	5 V DC	12 V DC	24 V DC	24 V UC	48 V UC
Rated control voltage	5 V DC ± 20 %	12 V DC ± 20 %	24 V DC ± 20 %	24 V UC ± 10 %	48 V UC ± 10 %
Rated current AC / DC	/ 33 mA	/ 18 mA	/ 11.5 mA	11.7 mA / 6.4 mA	8 mA / 7 mA
Power rating	170 mW	210 mW	280 mW	270 mVA / 154 mW	340 mW / 0.4 VA
Status indicator	Green LED	Green LED	Green LED	Green LED	Green LED
Protective circuit	Free-wheeling diode, Reverse polarity protection	Free-wheeling diode, Reverse polarity protection	Free-wheeling diode, Reverse polarity protection	Rectifier	Rectifier

Ordering data						
PUSH IN connection	Type	TRP 5VDC 1CO AU	TRP 12VDC 1CO AU	TRP 24VDC 1CO AU	TRP 24VUC 1CO AU	TRP 48VUC 1CO AU
	Order No.	<b>2618060000</b>	<b>2618120000</b>	<b>2618110000</b>	<b>2618160000</b>	<b>2618170000</b>
Screw connection	Type	TRS 5VDC 1CO AU	TRS 12VDC 1CO AU	TRS 24VDC 1CO AU	TRS 24VUC 1CO AU	TRS 48VUC 1CO AU
	Order No.	<b>1122980000</b>	<b>1122990000</b>	<b>1123000000</b>	<b>1123010000</b>	<b>1123020000</b>
Note						

**Ordering data**

Control side	60 V UC	120 V UC	230 V UC	120 V AC RC	230 V AC RC
Rated control voltage	60 V UC ± 10 %	120 V UC ± 10 %	230 V UC ± 10 %	120 V AC ± 10 %	230 V AC ± 10 %
Rated current AC / DC	4,8 mA / 2,8 mA	4 mA / 3,5 mA	3,5 mA / 2,9 mA	7 mA /	8,5 mA /
Power rating	170 mW, 290 mVA	0,48 VA, 420 mW	670 mW, 805 mVA	840 mVA	2 VA
Status indicator	Green LED	Green LED	Green LED	Green LED	Green LED
Protective circuit	Rectifier	Rectifier	Rectifier	Rectifier, RC element	Rectifier, RC element

Ordering data						
PUSH IN connection	Type	TRP 60VUC 1CO AU	TRP 120VUC 1CO AU	TRP 230VUC 1CO AU	TRP 120VAC RC 1CO AU	TRP 230VAC RC 1CO AU
	Order No.	<b>2618070000</b>	<b>2618080000</b>	<b>2618210000</b>	<b>2618030000</b>	<b>2617950000</b>
Screw connection	Type	TRS 60VUC 1CO AU	TRS 120VUC 1CO AU	TRS 230VUC 1CO AU	TRS 120VAC RC 1CO AU	TRS 230VAC RC 1CO AU
	Order No.	<b>1123030000</b>	<b>1123040000</b>	<b>1123050000</b>	<b>1123070000</b>	<b>1123080000</b>
Note						

1 CO contact

multi-voltage input

- Space-saving: width only 6.4 mm
- AgNi contact
- PUSH IN and screw connection
- Multi-voltage input: 24...230 V UC in one module

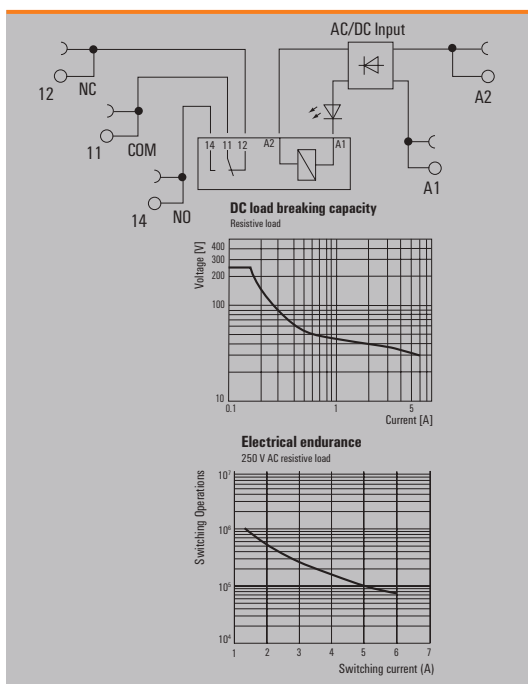

Technical data

Load side		
Rated switching voltage / Continuous current	250 V AC / 6 A	
Max. switching voltage, AC	250 V	
Inrush current	20 A / 20 ms	
Min. switching power	1 mA @ 24 V, 10 mA @ 12 V, 100 mA @ 5 V	
Contact type	1 CO contact (AgNi)	
Mechanical service life	5 x 10 <sup>6</sup> switching cycles	
Max. switching frequency at rated load	0.1 Hz	
General data		
Ambient temperature (operational)	-40 °C...60 °C	
Storage temperature	-40 °C...85 °C	
Humidity	5-95% relative humidity, T <sub>90</sub> = 40°C, without condensation	
Approvals	CE; cULus; DETNORVER; UKCA	
Insulation coordinates		
Rated voltage	300 V	
Impulse withstand voltage		
Dielectric strength for control side - load side	3.51 kV <sub>eff</sub> / 1 min.	
Dielectric strength of neighbouring contacts		
Dielectric strength to mounting rail	3.51 kV <sub>eff</sub> / 1 min.	
Clearance and creepage distances for control side - load side	≥ 6 mm	
Overvoltage category	III	
Pollution degree	2	
Dimensions		
	<b>PUSH IN</b>	<b>Screw connection</b>
Clamping range (nominal / min. / max.)	mm <sup>2</sup> 1.5 / 0.14 / 2.5	1.5 / 0.14 / 2.5
Depth x width x height	mm 87.8 / 6.4 / 89.4	87.8 / 6.4 / 89.6
Note		
Accessories and dimensional drawings: refer to the TERMSERIES Accessories page. Further approvals and technical data can be found at <a href="http://eshop.weidmueller.com">eshop.weidmueller.com</a>		

Ordering data

Control side	24 V - 230 V UC
Rated control voltage	24...230 V UC ± 10 %
Rated current AC / DC	19.0 mA @ 24 V AC, 3.0 mA @ 230 V AC / 11.0 mA @ 24 V DC, 1.1 mA @ 230 V DC
Power rating	265 mW @ 24 V DC, 255 mW @ 230 V DC, 455 mVA @ 24 V AC, 690 mVA @ 230 V AC
Status indicator	Green LED
Protective circuit	Rectifier
Approvals	CE; cULus; DETNORVER; UKCA

Ordering data	
PUSH IN connection	Type TRP 24-230VUC 1CO ED2
Order No.	<b>2663010000</b>
Screw connection	Type TRS 24-230VUC 1CO ED2
Order No.	<b>2662850000</b>
Note	

**1 CO contact with hard gold-plated contacts  
multi-voltage input**

- Space saving, just 6.4 mm modular width
- AgNi contact with gold plating
- PUSH IN and screw connection
- Multi-voltage input: 24...230 V UC in one module

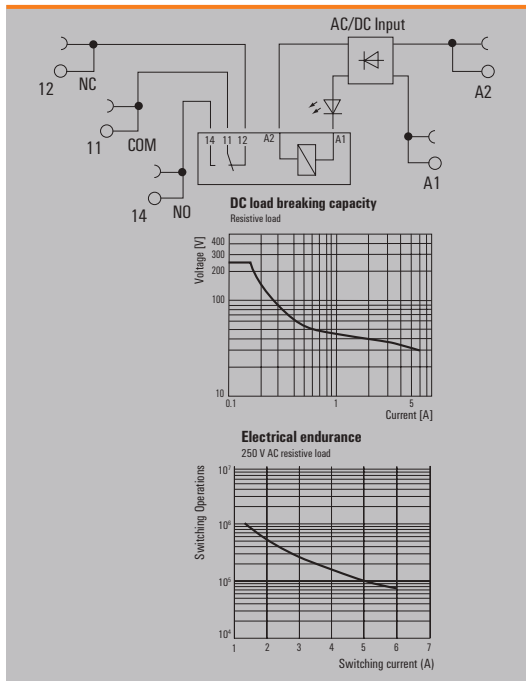

**Technical data**

Load side		
Rated switching voltage / Continuous current	250 V AC / 6 A	
Max. switching voltage, AC	250 V	
Inrush current	20 A / 20 ms	
Min. switching power	1 mA @ 1 V	
Contact type	1 CO contact (AgNi gold-plated)	
Mechanical service life	5 x 10 <sup>6</sup> switching cycles	
Max. switching frequency at rated load	0.1 Hz	
General data		
Ambient temperature (operational)	-40 °C...60 °C	
Storage temperature	-40 °C...85 °C	
Humidity	5-95% relative humidity, T <sub>90</sub> = 40°C, without condensation	
Approvals	CE; cULus; DETNORVER; UKCA	
Insulation coordinates		
Rated voltage	300 V	
Impulse withstand voltage		
Dielectric strength for control side - load side	3.51 kV <sub>eff</sub> / 1 min.	
Dielectric strength of neighbouring contacts		
Dielectric strength to mounting rail	3.51 kV <sub>eff</sub> / 1 min.	
Clearance and creepage distances for control side - load side	≥ 6 mm	
Overvoltage category	III	
Pollution degree	2	
Dimensions		
	<b>PUSH IN</b>	<b>Screw connection</b>
Clamping range (nominal / min. / max.)	mm <sup>2</sup> 1.5 / 0.14 / 2.5	1.5 / 0.14 / 2.5
Depth x width x height	mm 87.8 / 6.4 / 89.4	87.8 / 6.4 / 89.6
Note		
Accessories and dimensional drawings: refer to the TERMSERIES Accessories page. Further approvals and technical data can be found at <a href="http://eshop.weidmueller.com">eshop.weidmueller.com</a>		

**Ordering data**

Control side	
Rated control voltage	24...230 V UC ± 10 %
Rated current AC / DC	19.0 mA @ 24 V AC, 3.0 mA @ 230 V AC / 11.0 mA @ 24 V DC, 1.1 mA @ 230 V DC
Power rating	265 mW @ 24 V DC, 255 mW @ 230 V DC, 455 mVA @ 24 V AC, 690 mVA @ 230 V AC
Status indicator	Green LED
Protective circuit	Rectifier
Approvals	CE; cULus; DETNORVER; UKCA

Ordering data	
PUSH IN connection	Type TRP 24-230VUC 1CO AU ED2
Order No.	<b>2663020000</b>
Screw connection	Type TRS 24-230VUC 1CO AU ED2
Order No.	<b>2662860000</b>
Note	

**1 CO contact (AgSnO)**

**AC / DC / UC coil**

- Space-saving, only 6.4 mm wide
- AgSnO contact
- For capacitive and inductive loads
- PUSH IN and screw connection



**B**

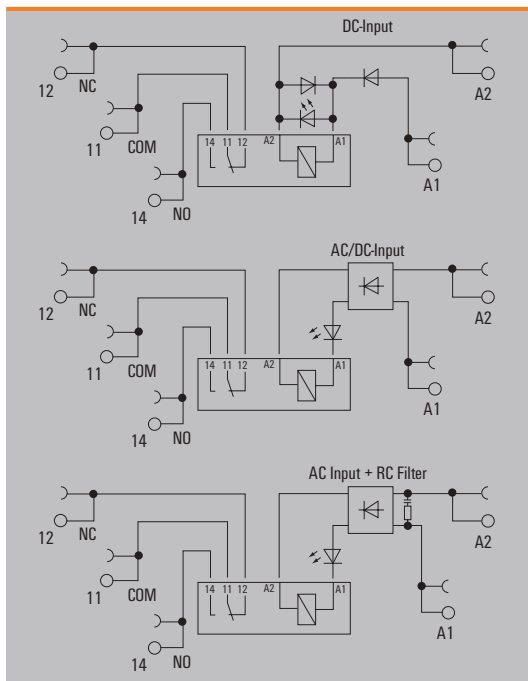

**Technical data**

Load side	
Rated switching voltage / Continuous current	250 V AC / 6 A
Max. switching voltage, AC	250 V
Inrush current	30 A / 20 ms
Min. switching power	100 mA @ 12 V
Contact type	1 CO contact (AgSnO)
Mechanical service life	5 x 10 <sup>6</sup> switching cycles
Max. switching frequency at rated load	0.1 Hz
General data	
Ambient temperature (operational)	-40 °C...60 °C
Storage temperature	-40 °C...85 °C
Humidity	5-95% relative humidity, T <sub>90</sub> = 40°C, without condensation
Approvals	CE; cULus; DETNORVER; UKCA
Insulation coordinates	
Rated voltage	300 V
Impulse withstand voltage	6 kV (1.2/50 µs)
Dielectric strength for control side - load side	4 kV <sub>eff</sub> / 1 Min.
Dielectric strength of neighbouring contacts	
Dielectric strength to mounting rail	4 kV <sub>eff</sub> / 1 Min.
Clearance and creepage distances for control side - load side	≥ 6 mm
Overvoltage category	III
Pollution degree	2
Dimensions	
Clamping range (nominal / min. / max.)	mm <sup>2</sup> 1.5 / 0.14 / 2.5
Depth x width x height	mm 87.8 / 6.4 / 89.4
	mm 87.8 / 6.4 / 89.6
Note	
Accessories and dimensional drawings: refer to the TERMSERIES Accessories page. Further approvals and technical data can be found at <a href="http://eshop.weidmueller.com">eshop.weidmueller.com</a>	

**Applications**

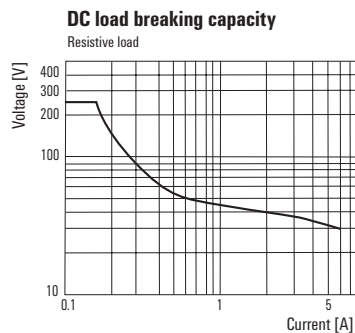
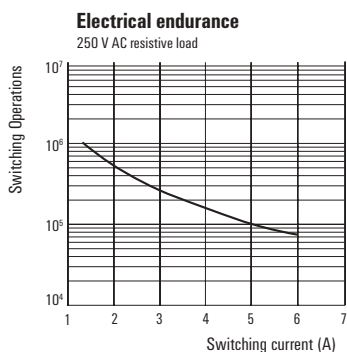

**1 CO contact (AgSnO)**  
**AC / DC / UC coil**

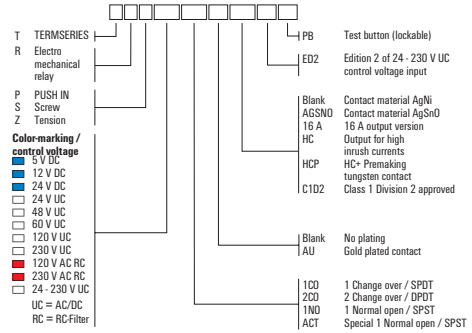

**Ordering data**

	5 V DC	12 V DC	24 V DC	24 V UC	48 V UC
<b>Control side</b>					
Rated control voltage	5 V DC ± 20 %	12 V DC ± 20 %	24 V DC ± 20 %	24 V UC ± 10 %	48 V UC ± 10 %
Rated current AC / DC	/ 33 mA	/ 18 mA	/ 11.5 mA	11.7 mA / 6.4 mA	8 mA / 7 mA
Power rating	170 mW	210 mW	280 mW	270 mVA / 154 mW	340 mW / 0.4 VA
Status indicator	Green LED	Green LED	Green LED	Green LED	Green LED
Protective circuit	Free-wheeling diode, Reverse polarity protection	Free-wheeling diode, Reverse polarity protection	Free-wheeling diode, Reverse polarity protection	Rectifier	Rectifier

Ordering data					
PUSH IN connection Type	TRP 5VDC 1CO AGSNO	TRP 12VDC 1CO AGSNO	TRP 24VDC 1CO AGSNO	TRP 24VUC 1CO AGSNO	TRP 48VUC 1CO AGSNO
Order No.	<b>2614820000</b>	<b>2617860000</b>	<b>2618020000</b>	<b>2617880000</b>	<b>2617890000</b>
Screw connection Type	TRS 5VDC 1CO AGSNO	TRS 12VDC 1CO AGSNO	TRS 24VDC 1CO AGSNO	TRS 24VUC 1CO AGSNO	TRS 48VUC 1CO AGSNO
Order No.	<b>2152860000</b>	<b>2152880000</b>	<b>1984540000</b>	<b>2152940000</b>	<b>2153060000</b>
Note					

**Ordering data**

	60 V UC	120 V UC	230 V UC	120 V AC RC	230 V AC RC
<b>Control side</b>					
Rated control voltage	60 V UC ± 10 %	120 V UC ± 10 %	230 V UC ± 10 %	120 V AC ± 10 %	230 V AC ± 10 %
Rated current AC / DC	4,8 mA / 2,8 mA	4 mA / 3,5 mA	3,5 mA / 2,9 mA	7 mA /	8,8 mA /
Power rating	170 mW, 290 mVA	0,48 VA, 420 mW	670 mW, 805 mVA	840 mVA	2 VA
Status indicator	Green LED	Green LED	Green LED	Green LED	Green LED
Protective circuit	Rectifier	Rectifier	Rectifier	Rectifier, RC element	Rectifier, RC element

Ordering data					
PUSH IN connection Type	TRP 60VUC 1CO AGSNO	TRP 120VUC 1CO AGSNO	TRP 230VUC 1CO AGSNO	TRP 120VAC RC 1CO AGSNO	TRP 230VAC RC 1CO AGSNO
Order No.	<b>2617870000</b>	<b>2617900000</b>	<b>2617830000</b>	<b>2617840000</b>	<b>2617850000</b>
Screw connection Type	TRS 60VUC 1CO AGSNO	TRS 120VUC 1CO AGSNO	TRS 230VUC 1CO AGSNO	TRS 120VAC RC 1CO AGSNO	TRS 230VAC RC 1CO AGSNO
Order No.	<b>2153550000</b>	<b>2153570000</b>	<b>2153590000</b>	<b>2152900000</b>	<b>2152920000</b>
Note					

1 CO contact (AgSnO)

Multi-voltage input

- Space-saving, only 6.4 mm wide
- AgSnO contact
- For capacitive and inductive loads
- PUSH IN and screw connection
- Multi-voltage input: 24...230 V UC in one module

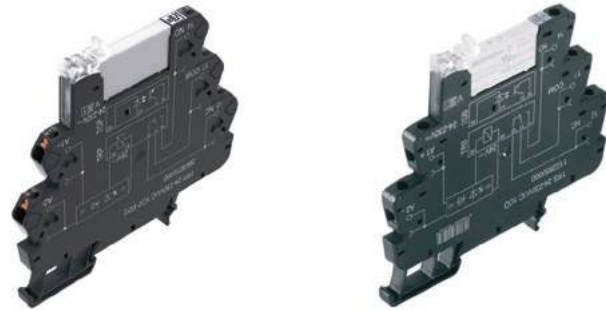

B

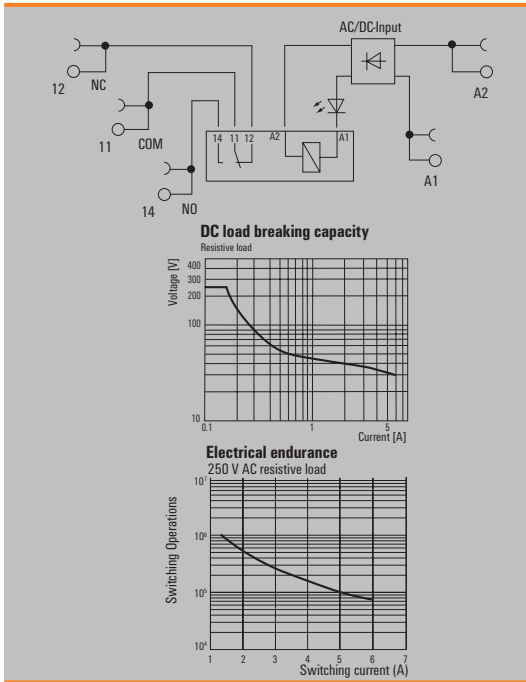

Technical data

Load side		
Rated switching voltage / Continuous current	250 V AC / 6 A	
Max. switching voltage, AC	250 V	
Inrush current	30 A / 20 ms	
Min. switching power	100 mA @ 12 V	
Contact type	1 CO contact (AgSnO)	
Mechanical service life	5 x 10 <sup>6</sup> switching cycles	
Max. switching frequency at rated load	0.1 Hz	
General data		
Ambient temperature (operational)	-40 °C...60 °C	
Storage temperature	-40 °C...85 °C	
Humidity	5-95% relative humidity, T <sub>0</sub> = 40°C, without condensation	
Approvals	CE; cULus; DETNORVER; UKCA	
Insulation coordinates		
Rated voltage	300 V	
Impulse withstand voltage		
Dielectric strength for control side - load side	3.51 kV <sub>eff</sub> / 1 min.	
Dielectric strength of neighbouring contacts		
Dielectric strength to mounting rail	3.51 kV <sub>eff</sub> / 1 min.	
Clearance and creepage distances for control side - load side	≥ 6 mm	
Overvoltage category	III	
Pollution degree	2	
Dimensions		
	PUSH IN	Screw connection
Clamping range (nominal / min. / max.)	mm <sup>2</sup> 1.5 / 0.14 / 2.5	1.5 / 0.14 / 2.5
Depth x width x height	mm 87.8 / 6.4 / 89.4	87.8 / 6.4 / 89.6
Note	Accessories and dimensional drawings: refer to the TERMSERIES Accessories page. Further approvals and technical data can be found at <a href="http://eshop.weidmueller.com">eshop.weidmueller.com</a>	

Ordering data

Control side	24 V - 230 V UC
Rated control voltage	24...230 V UC ± 10 %
Rated current AC / DC	19.0 mA @ 24 V AC, 3.0 mA @ 230 V AC / 11.0 mA @ 24 V DC, 1.1 mA @ 230 V DC
Power rating	265 mW @ 24 V DC, 255 mW @ 230 V DC, 455 mVA @ 24 V AC, 690 mVA @ 230 V AC
Status indicator	Green LED
Protective circuit	Rectifier
Approvals	CE; cULus; DETNORVER; UKCA

Ordering data	
PUSH IN connection	Type TRP 24-230VUC 1CO AGSNO ED2
Order No.	<b>2663160000</b>
Screw connection	Type TRS 24-230VUC 1CO AGSNO ED2
Order No.	<b>2663000000</b>

Note



**1 CO AgSnO**  
with test button

- Space-saving, only 6.4 mm wide
- AgSnO contact
- For capacitive and inductive loads
- PUSH IN and screw connection
- With test button



**B**

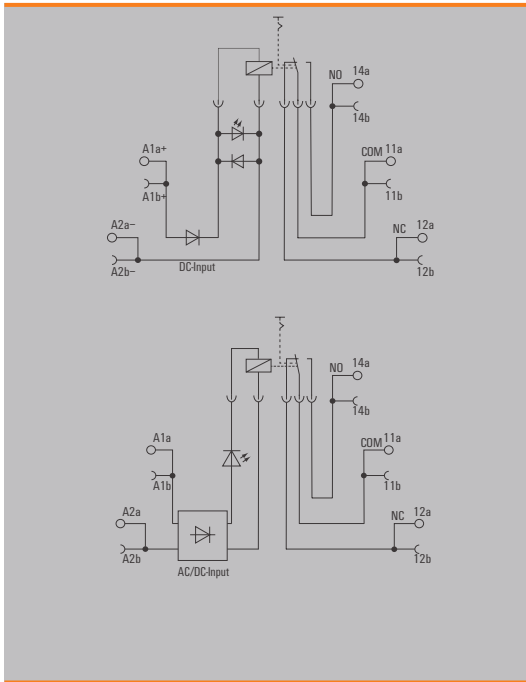

**Technical data**

Load side	
Rated switching voltage / Continuous current	250 V AC / 6 A
Max. switching voltage, AC	250 V
Inrush current	30 A / 20 ms
Min. switching power	100 mA @ 12 V
Contact type	1 CO contact (AgSnO)
Mechanical service life	10 x 10 <sup>6</sup> switching cycles
Max. switching frequency at rated load	0.1 Hz
General data	
Ambient temperature (operational)	-40 °C...60 °C
Storage temperature	-40 °C...85 °C
Humidity	5-95% relative humidity, T <sub>0</sub> = 40°C, without condensation
Approvals	CE; cULus
Insulation coordinates	
Rated voltage	300 V
Impulse withstand voltage	6 kV (1.2/50 µs)
Dielectric strength for control side - load side	3.51 kV <sub>eff</sub> /1 min.
Dielectric strength of neighbouring contacts	
Dielectric strength to mounting rail	4 kV <sub>eff</sub> / 1 Min.
Clearance and creepage distances for control side - load side	≥ 6 mm
Overvoltage category	III
Pollution degree	2

Dimensions		PUSH IN	Screw connection
Clamping range (nominal / min. / max.)	mm <sup>2</sup>	1.5 / 0.14 / 2.5	1.5 / 0.14 / 2.5
Depth x width x height	mm	87.8 / 6.4 / 89.4	87.8 / 6.4 / 89.6

**Note**

**1 CO AgSnO**  
with test button

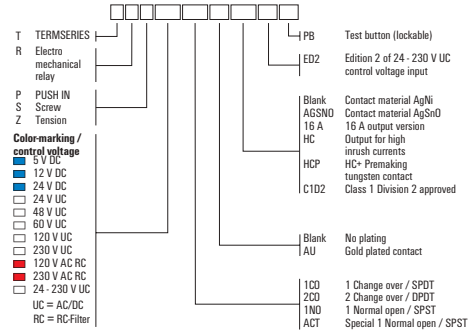

**Ordering data**

	24 V DC	24 V UC
<b>Control side</b>		
Rated control voltage	24 V DC ± 20 %	24 V UC ± 10 %
Rated current AC / DC	/ 11.5 mA	11.7 mA / 6.4 mA
Power rating	280 mW	270 mVA / 154 mW
Status indicator	Green LED	Green LED
Protective circuit	Free-wheeling diode, Reverse polarity protection	Rectifier

Ordering data			
PUSH IN connection	Type	TRP 24VDC 1CO AGSNO PB	TRP 24VUC 1CO AGSNO PB
	Order No.	2855800000	2855810000
Screw connection	Type	TRS 24VDC 1CO AGSNO PB	TRS 24VUC 1CO AGSNO PB
	Order No.	2855870000	2855890000
<b>Note</b>			

1 CO AgSnO

with test button

Multi-voltage input

- Space-saving, only 6.4 mm wide
- AgSnO contact
- For capacitive and inductive loads
- PUSH IN and screw connection
- Multi-voltage input: 24...230 V UC in one module
- With test button

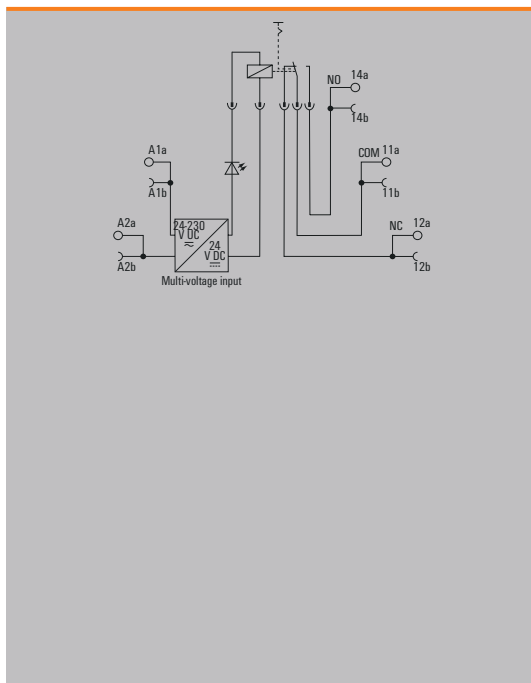
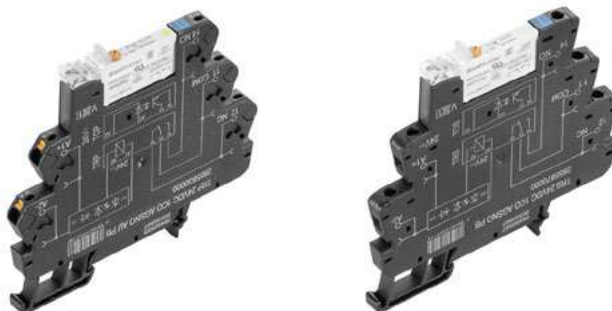

Technical data

Load side		
Rated switching voltage / Continuous current	250 V AC / 6 A	
Max. switching voltage, AC	250 V	
Inrush current	30 A / 20 ms	
Min. switching power	100 mA @ 12 V	
Contact type	1 CO contact (AgSnO)	
Mechanical service life	10 x 10 <sup>6</sup> switching cycles	
Max. switching frequency at rated load	0.1 Hz	
General data		
Ambient temperature (operational)	-40 °C...60 °C	
Storage temperature	-40 °C...85 °C	
Humidity	5-95% relative humidity, T <sub>0</sub> = 40°C, without condensation	
Approvals	CE; cULus	
Insulation coordinates		
Rated voltage	300 V	
Impulse withstand voltage	6 kV (1.2/50 µs)	
Dielectric strength for control side - load side	3.51 kV <sub>eff</sub> / 1 min.	
Dielectric strength of neighbouring contacts		
Dielectric strength to mounting rail	4 kV <sub>eff</sub> / 1 Min.	
Clearance and creepage distances for control side - load side	≥ 6 mm	
Overvoltage category	III	
Pollution degree	2	
Dimensions		
	<b>PUSH IN</b>	<b>Screw connection</b>
Clamping range (nominal / min. / max.)	mm <sup>2</sup> 1.5 / 0.14 / 2.5	1.5 / 0.14 / 2.5
Depth x width x height	mm 87.8 / 6.4 / 89.4	87.8 / 6.4 / 89.6
Note		

Ordering data

24 - 230 V UC

Control side	
Rated control voltage	24...230 V UC ± 10 %
Rated current AC / DC	19.0 mA @ 24 V AC, 3.0 mA @ 230 V AC / 11.0 mA @ 24 V DC, 1.1 mA @ 230 V DC
Power rating	265 mW @ 24 V DC, 255 mW @ 230 V DC, 455 mVA @ 24 V AC, 690 mVA @ 230 V AC
Status indicator	Green LED
Protective circuit	Rectifier
Approvals	CE; cULus

Ordering data	
PUSH IN connection	Type TRP 24-230VUC 1CO AGSNO ED2 PB
	Order No. <b>2855910000</b>
Screw connection	Type TRS 24-230VUC 1CO AGSNO ED2 PB
	Order No. <b>2855930000</b>

Note	



**1 CO AgSnO with hard gold-plated contacts with test button**

- Space-saving, only 6.4 mm wide
- AgSnO contact with hard gold-plated contact
- For capacitive and inductive loads
- PUSH IN and screw connection
- With test button

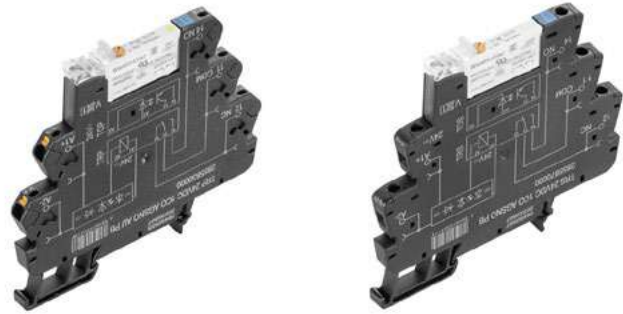

**B**

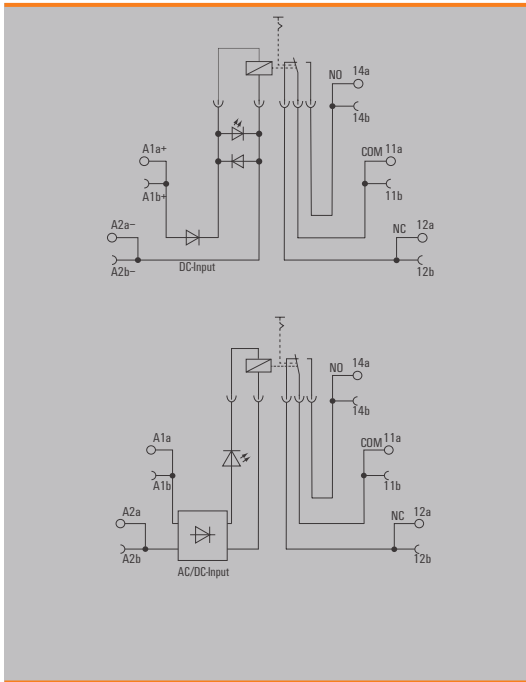

**Technical data**

Load side		
Rated switching voltage / Continuous current	250 V AC / 6 A	
Max. switching voltage, AC	250 V	
Inrush current	30 A / 20 ms	
Min. switching power	1 mA @ 1 V	
Contact type	1 CO contact (AgSnO gold-plated)	
Mechanical service life	10 x 10 <sup>6</sup> switching cycles	
Max. switching frequency at rated load	0.1 Hz	
General data		
Ambient temperature (operational)	-40 °C...60 °C	
Storage temperature	-40 °C...85 °C	
Humidity	5-95% relative humidity, T <sub>0</sub> = 40°C, without condensation	
Approvals	CE; cULus	
Insulation coordinates		
Rated voltage	300 V	
Impulse withstand voltage	6 kV (1.2/50 µs)	
Dielectric strength for control side - load side	3.51 kV <sub>eff</sub> /1 min.	
Dielectric strength of neighbouring contacts		
Dielectric strength to mounting rail	4 kV <sub>eff</sub> / 1 Min.	
Clearance and creepage distances for control side - load side	≥ 6 mm	
Overvoltage category	III	
Pollution degree	2	
Dimensions		
	<b>PUSH IN</b>	<b>Screw connection</b>
Clamping range (nominal / min. / max.)	mm <sup>2</sup> 1.5 / 0.14 / 2.5	1.5 / 0.14 / 2.5
Depth x width x height	mm 87.8 / 6.4 / 89.4	87.8 / 6.4 / 89.6
<b>Note</b>		

**1 CO AgSnO with hard gold-plated contacts  
with test button**

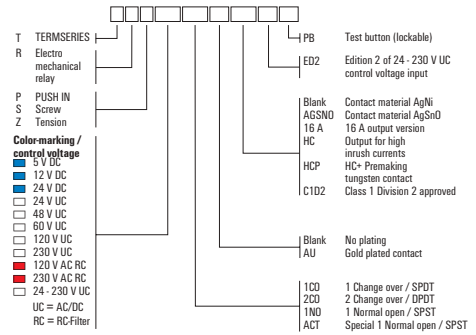

**Ordering data**

	24 V DC	24 V UC
<b>Control side</b>		
Rated control voltage	24 V DC ± 20 %	24 V UC ± 10 %
Rated current AC / DC	/ 11.5 mA	11.7 mA / 6.4 mA
Power rating	280 mW	270 mVA / 154 mW
Status indicator	Green LED	Green LED
Protective circuit	Free-wheeling diode, Reverse polarity protection	Rectifier

Ordering data			
PUSH IN connection	Type	TRP 24VDC 1CO AGSNO AU PB	TRP 24VUC 1CO AGSNO AU PB
	Order No.	<b>2855830000</b>	<b>2855820000</b>
Screw connection	Type	TRS 24VDC 1CO AGSNO AU PB	TRS 24VUC 1CO AGSNO AU PB
	Order No.	<b>2855860000</b>	<b>2855880000</b>
<b>Note</b>			

**1 CO AgSnO with hard gold-plated contacts with test button**

**Multi-voltage input**

- Space-saving, only 6.4 mm wide
- AgSnO contact with hard gold-plated contact
- PUSH IN and screw connection
- Multi-voltage input: 24...230 V UC in one module
- With test button

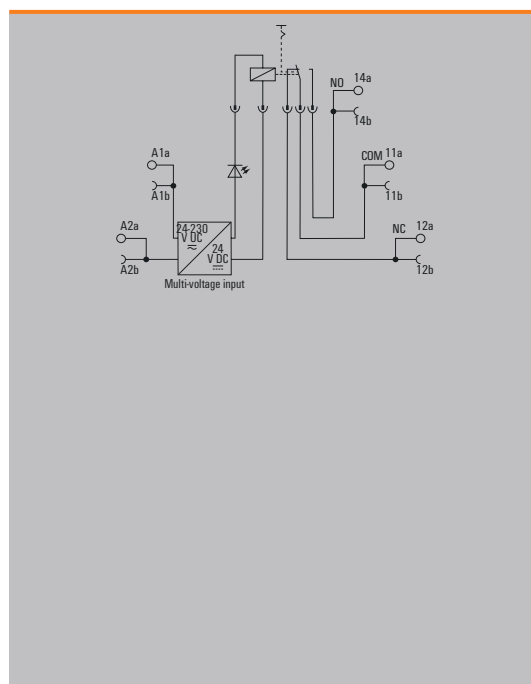
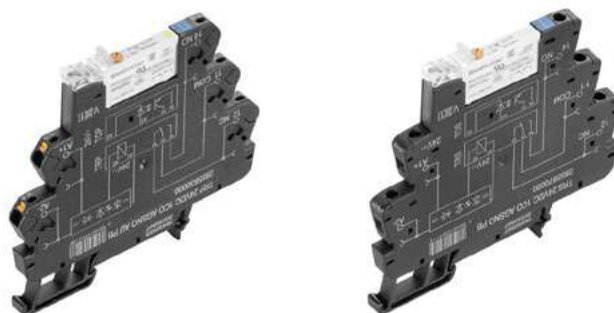

**Technical data**

Load side		
Rated switching voltage / Continuous current	250 V AC / 6 A	
Max. switching voltage, AC	250 V	
Inrush current	30 A / 20 ms	
Min. switching power	1 mA @ 1 V	
Contact type	1 CO contact (AgSnO gold-plated)	
Mechanical service life	10 x 10 <sup>6</sup> switching cycles	
Max. switching frequency at rated load	0.1 Hz	
General data		
Ambient temperature (operational)	-40 °C...60 °C	
Storage temperature	-40 °C...85 °C	
Humidity	5-95% relative humidity, T <sub>0</sub> = 40°C, without condensation	
Approvals	CE; cULus	
Insulation coordinates		
Rated voltage	300 V	
Impulse withstand voltage	6 kV (1.2/50 µs)	
Dielectric strength for control side - load side	3.51 kV <sub>eff</sub> / 1 min.	
Dielectric strength of neighbouring contacts		
Dielectric strength to mounting rail	4 kV <sub>eff</sub> / 1 Min.	
Clearance and creepage distances for control side - load side	≥ 6 mm	
Overvoltage category	III	
Pollution degree	2	
Dimensions		
	<b>PUSH IN</b>	<b>Screw connection</b>
Clamping range (nominal / min. / max.)	mm <sup>2</sup> 1.5 / 0.14 / 2.5	1.5 / 0.14 / 2.5
Depth x width x height	mm 87.8 / 6.4 / 89.4	87.8 / 6.4 / 89.6
Note		

**Ordering data**

**24 - 230 V UC**

Control side	
Rated control voltage	24...230 V UC ± 10 %
Rated current AC / DC	19.0 mA @ 24 V AC, 3.0 mA @ 230 V AC / 11.0 mA @ 24 V DC, 1.1 mA @ 230 V DC
Power rating	265 mW @ 24 V DC, 255 mW @ 230 V DC, 455 mVA @ 24 V AC, 690 mVA @ 230 V AC
Status indicator	Green LED
Protective circuit	Rectifier
Approvals	CE; cULus

Ordering data	
PUSH IN connection	Type TRP 24-230VUC 1CO AGSNO AU ED2 PB Order No. <b>2855900000</b>
Screw connection	Type TRS 24-230VUC 1CO AGSNO AU ED2 PB Order No. <b>2855920000</b>

Note	



**1 CO AgNi**  
with test button

- Space-saving, only 12.8 mm wide
- AgNi contact
- For capacitive and inductive loads
- PUSH IN and screw connection
- With test button



**B**

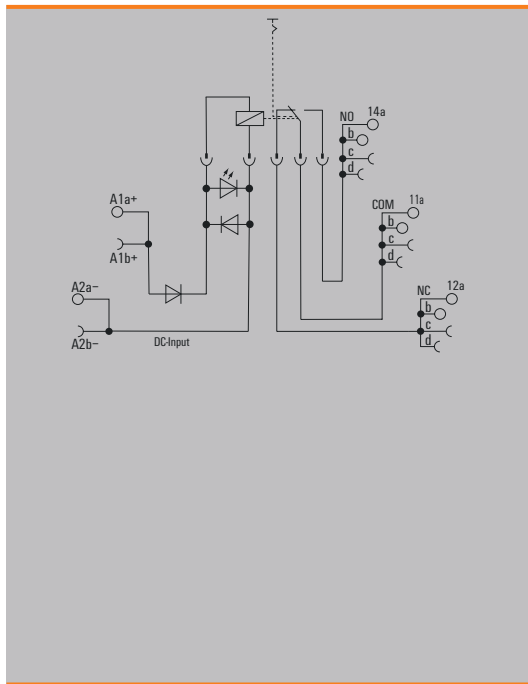

**Technical data**

Load side	
Rated switching voltage / Continuous current	250 V AC / 16 A
Max. switching voltage, AC	250 V
Inrush current	30 A / 4 s
Min. switching power	
Contact type	1 CO contact (AgNi)
Mechanical service life	30 x 10 <sup>6</sup> switching cycles
Max. switching frequency at rated load	0.1 Hz
General data	
Ambient temperature (operational)	-40 °C...60 °C
Storage temperature	-40 °C...70 °C
Humidity	5...85 % rel. humidity, no condensation
Approvals	CE; cULus
Insulation coordinates	
Rated voltage	300 V
Impulse withstand voltage	6 kV (1.2/50 µs)
Dielectric strength for control side - load side	2.5 kV <sub>eff</sub> / 1 Min.
Dielectric strength of neighbouring contacts	
Dielectric strength to mounting rail	4 kV <sub>eff</sub> / 1 Min.
Clearance and creepage distances for control side - load side	≥ 5.5 mm
Overvoltage category	III
Pollution degree	2
Dimensions	
Clamping range (nominal / min. / max.)	mm <sup>2</sup> 1.5 / 0.14 / 2.5
Depth x width x height	mm 97.5 / 12.8 / 89.4
	<b>PUSH IN</b> 1.5 / 0.14 / 2.5
	<b>Screw connection</b> 1.5 / 0.14 / 2.5
	97.5 / 12.8 / 89.6
Note	

**1 CO AgNi**  
with test button

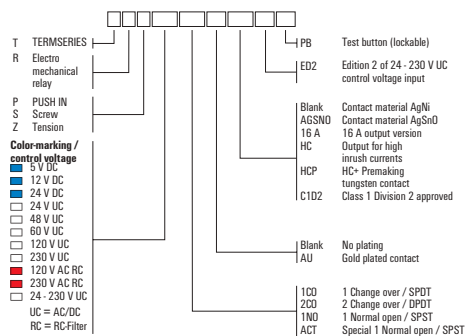

**Ordering data**

**Control side**

	24 V DC	24 V UC	120 V UC	230 V UC
Rated control voltage	19.2 V...24 V...28.8 V DC ± 20 %	24 V UC ± 10 %	108 V...120 V...132 V UC ± 10 %	218.5 V...230 V...241.5 V UC ± 5 %
Rated current AC / DC	/ 20.5 mA	/ 16.7 mA	/ 4.3 mA	/ 4.3 mA
Power rating	495 mW	430 mVA @ 24 V AC	480 mW	
Status indicator	Green LED	Green LED	Green LED	Green LED
Protective circuit	Free-wheeling diode, Reverse polarity protection	Free-wheeling diode, Reverse polarity protection	Free-wheeling diode, Reverse polarity protection	Free-wheeling diode, Reverse polarity protection

**Ordering data**

PUSH IN connection	Type	TRP 24VDC 1CO 16A PB	TRP 24VUC 1CO 16A PB	TRP 120VUC 1CO 16A PB	TRP 230VUC 1CO 16A PB
Order No.		<b>2988280000</b>	<b>2988300000</b>	<b>2988310000</b>	<b>2988320000</b>
Screw connection	Type	TRS 24VDC 1CO 16A PB	TRS 24VUC 1CO 16A PB	TRS 120VUC 1CO 16A PB	TRS 230VUC 1CO 16A PB
Order No.		<b>2988390000</b>	<b>2988400000</b>	<b>2988410000</b>	<b>2988420000</b>

**Note**

--	--	--	--	--	--

Universal range

B

1 CO AgNi

with test button

Multi-voltage input

- Space-saving, only 12.8 mm wide
- AgNi contact
- For capacitive and inductive loads
- PUSH IN and screw connection
- Multi-voltage input: 24...230 V UC in one module
- With test button

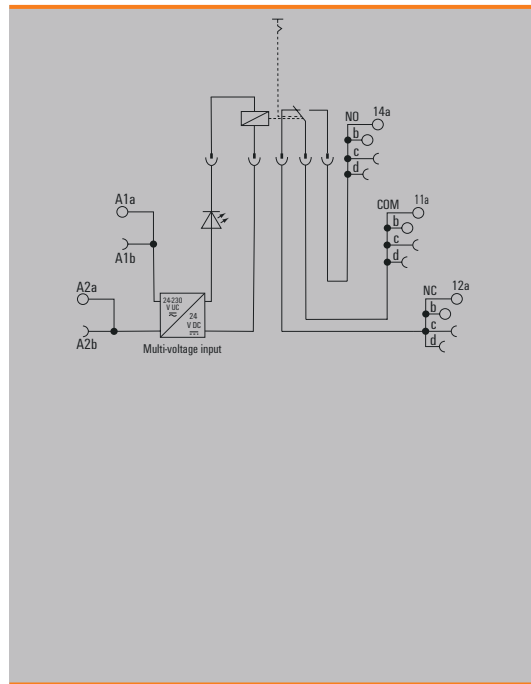

Technical data

Load side		
Rated switching voltage / Continuous current	250 V AC / 16 A	
Max. switching voltage, AC	250 V	
Inrush current	30 A / 4 s	
Min. switching power	100 mA @ 10 V	
Contact type	1 CO contact (AgNi)	
Mechanical service life	5 x 10 <sup>6</sup> switching cycles	
Max. switching frequency at rated load	0.1 Hz	
General data		
Ambient temperature (operational)	-40 °C...60 °C	
Storage temperature	-40 °C...70 °C	
Humidity	5...85 % rel. humidity, no condensation	
Approvals	CE; cULus	
Insulation coordinates		
Rated voltage	300 V	
Impulse withstand voltage	6 kV (1.2/50 µs)	
Dielectric strength for control side - load side	2.5 kV <sub>eff</sub> / 1 Min.	
Dielectric strength of neighbouring contacts		
Dielectric strength to mounting rail	4 kV <sub>eff</sub> / 1 Min.	
Clearance and creepage distances for control side - load side	≥ 5.5 mm	
Overvoltage category	III	
Pollution degree	2	
Dimensions		
	<b>PUSH IN</b>	<b>Screw connection</b>
Clamping range (nominal / min. / max.)	mm <sup>2</sup> 1.5 / 0.14 / 2.5	1.5 / 0.14 / 2.5
Depth x width x height	mm 97.5 / 12.8 / 89.4	97.5 / 12.8 / 89.6
Note		

Ordering data

24 - 230 V UC

Control side	
Rated control voltage	21.6...253 V UC ± 10 %
Rated current AC / DC	/ 16.7 mA
Power rating	0.82 W
Status indicator	Green LED
Protective circuit	Free-wheeling diode, Reverse polarity protection
Approvals	CE; cULus

Ordering data	
PUSH IN connection	Type TRP 24-230VUC 1CO 16A ED2 PB
Order No.	<b>2988330000</b>
Screw connection	Type TRS 24-230VUC 1CO 16A ED2 PB
Order No.	<b>2988430000</b>

Note	



**1 NO contact (actuator)**

- Space-saving, only 6.4 mm wide
  - AgNi contact
  - PUSH IN and screw connection
  - 24 V DC actuator version:
- Bridgeable, potential-free connection in the output (DC)
- Optional with test button



**B**

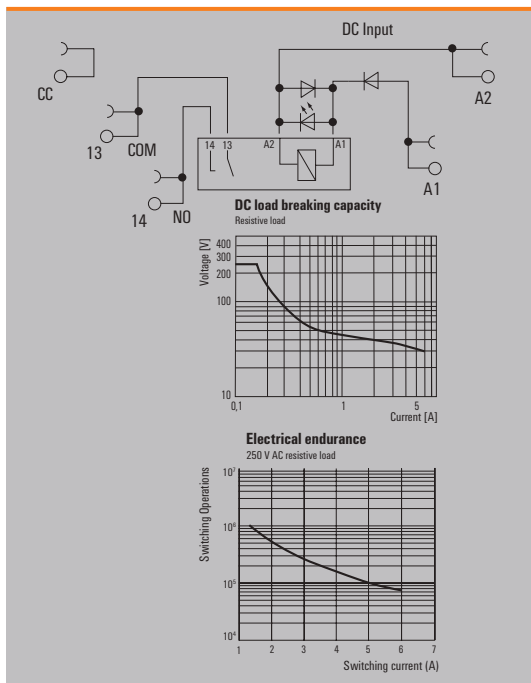

**Technical data**

Load side		
Rated switching voltage / Continuous current	250 V AC / 6 A	
Max. switching voltage, AC	250 V	
Inrush current	20 A / 20 ms	
Min. switching power	1 mA @ 24 V, 10 mA @ 12 V, 100 mA @ 5 V	
Contact type	1 NO contact (AgNi)	
Mechanical service life	5 x 10 <sup>6</sup> switching cycles	
Max. switching frequency at rated load	0.1 Hz	
General data		
Ambient temperature (operational)	-40 °C...60 °C	
Storage temperature	-40 °C...85 °C	
Humidity	5-95% relative humidity, T <sub>90</sub> = 40°C, without condensation	
Approvals	CE; cULus; DETNORVER; UKCA	
Insulation coordinates		
Rated voltage	300 V	
Impulse withstand voltage	6 kV (1.2/50 µs)	
Dielectric strength for control side - load side	4 kV <sub>eff</sub> / 1 Min.	
Dielectric strength of neighbouring contacts		
Dielectric strength to mounting rail	4 kV <sub>eff</sub> / 1 Min.	
Clearance and creepage distances for control side - load side	≥ 6 mm	
Overvoltage category	III	
Pollution degree	2	
Dimensions		
	<b>PUSH IN</b>	<b>Screw connection</b>
Clamping range (nominal / min. / max.)	mm <sup>2</sup> 1.5 / 0.14 / 2.5	1.5 / 0.14 / 2.5
Depth x width x height	mm 87.8 / 6.4 / 89.4	87.8 / 6.4 / 89.6
Note		
Accessories and dimensional drawings: refer to the TERMSERIES Accessories page. Further approvals and technical data can be found at <a href="http://eshop.weidmueller.com">eshop.weidmueller.com</a>		

**Ordering data**

Control side	24 V DC ACT	24VDC ACT PB
Rated control voltage	24 V DC ± 20 %	24 V DC ± 20 %
Rated current AC / DC	/ 11.5 mA	/ 11.5 mA
Power rating	280 mW	280 mW
Status indicator	Green LED	Green LED
Protective circuit	Free-wheeling diode, Reverse polarity protection	Free-wheeling diode, Reverse polarity protection

Ordering data			
PUSH IN connection	Type	TRP 24VDC ACT	TRP 24VDC ACT PB
	Order No.	<b>2618230000</b>	<b>2855840000</b>
Screw connection	Type	TRS 24VDC ACT	TRS 24VDC ACT PB
	Order No.	<b>1381900000</b>	<b>2855850000</b>
Note			

1 NO contact (actuator) – wiring optimization

Space and time optimized wiring of actuators

The lower the wiring effort, the higher the cost-effectiveness. With TERMSERIES actuator variants, supply and return wire for the load can be connected directly to the relay module. This eliminates the need for additional terminal blocks and significantly reduces wiring time. In addition, TERMSERIES interface adapters and cross-connectors ensure efficient wiring by eliminating the need for time-consuming and costly single-wire wiring.

Space requirement for an 8-channel system with a standard TERMSERIES1CO relay

Example of output wiring to show the difference in 8 loads to be wired:

Result width = 8 x 5.1 mm (2-pole terminal block) + 1 x 2.1 mm (end plate) + 8 x 6.4 mm (TRP 24VDC 1CO) + 3 x 8.0 mm (end bracket) = 118.1 mm

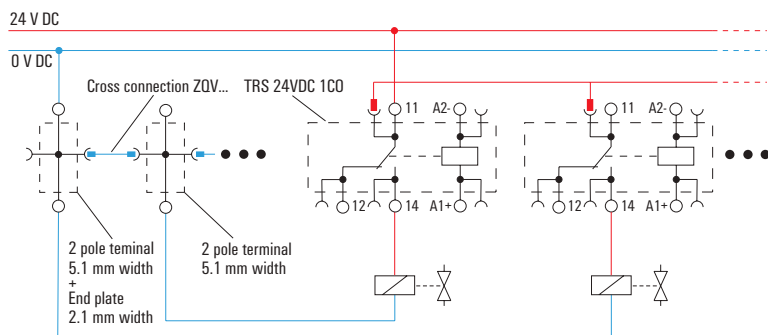

Space requirement top view:

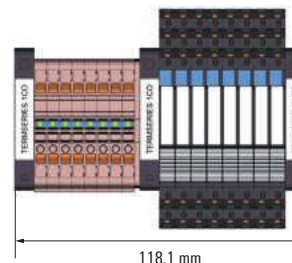

Space requirement for an 8-channel system with TERMSERIES ACT version relays and supply terminals

Example of output wiring to show the difference in 8 loads to be wired:

Result width = 1 x 6.4 mm (TRP SUPPLY) + 8 x 6.4 mm (TRP 24VDC ACT) + 2 x 8.0 mm (end bracket) = 73.6 mm

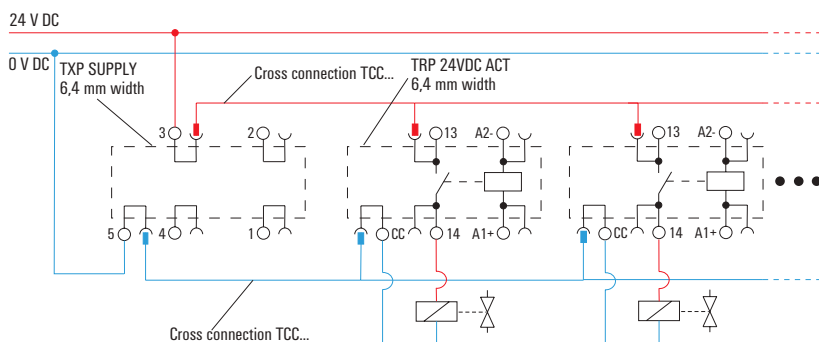

Space requirement top view:

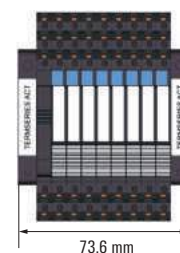

**1 CO contact**  
**AC / DC / UC coil**

- Space-saving, 12.8 mm wide
- 16 A AgNi contact
- Internal cross-connection of the output terminals
- PUSH IN and screw connection

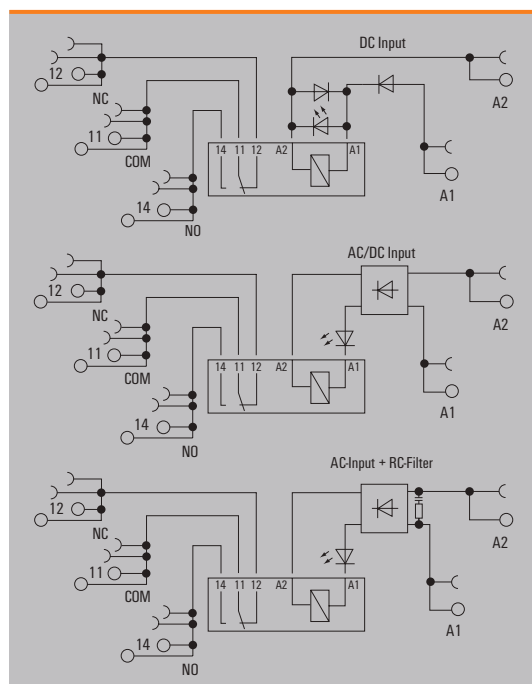
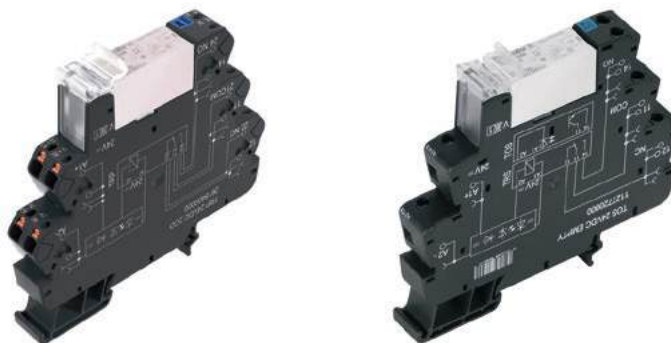

**Technical data**

Load side	
Rated switching voltage / Continuous current	250 V AC / 16 A
Max. switching voltage, AC	250 V
Inrush current	30 A / 4 s
Min. switching power	10 mA @ 10 V, 100 mA @ 5 V
Contact type	1 CO contact (AgNi)
Mechanical service life	30 x 10 <sup>6</sup> switching cycles
Max. switching frequency at rated load	0.1 Hz
General data	
Ambient temperature (operational)	-40 °C...60 °C
Storage temperature	-40 °C...85 °C
Humidity	5-95% relative humidity, T <sub>0</sub> = 40°C, without condensation
Approvals	CE; cULus; DETNORVER; UKCA
Insulation coordinates	
Rated voltage	300 V
Impulse withstand voltage	6 kV (1.2/50 µs)
Dielectric strength for control side - load side	1.2 kV <sub>eff</sub> / 5 s
Dielectric strength of neighbouring contacts	
Dielectric strength to mounting rail	4 kV <sub>eff</sub> / 1 Min.
Clearance and creepage distances for control side - load side	≥ 6 mm
Overvoltage category	III
Pollution degree	2
Dimensions	
Clamping range (nominal / min. / max.)	mm <sup>2</sup> 1.5 / 0.14 / 2.5
Depth x width x height	mm 87.8 / 12.8 / 89.4
	mm 87.8 / 12.8 / 89.6
Note	
Accessories and dimensional drawings: refer to the TERMSERIES Accessories page. Further approvals and technical data can be found at <a href="http://eshop.weidmueller.com">eshop.weidmueller.com</a>	

**Applications**

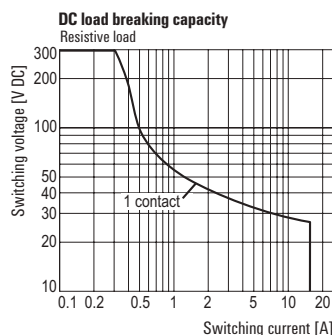
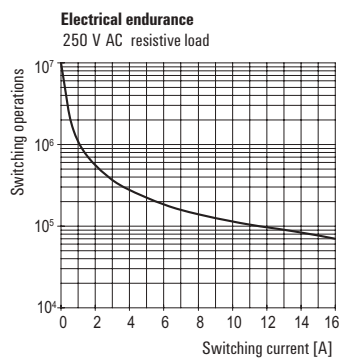

**1 CO contact**  
**AC / DC / UC coil**

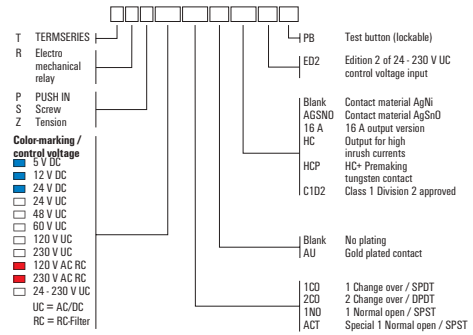

**Ordering data**

	5 V DC	12 V DC	24 V DC	24 V UC	48 V UC
<b>Control side</b>					
Rated control voltage	5 V DC ± 20 %	12 V DC ± 20 %	24 V DC ± 20 %	24 V UC ± 10 %	48 V UC ± 10 %
Rated current AC / DC	/ 70 mA	/ 33.3 mA	/ 21 mA	16 mA / 14 mA	9 mA / 7 mA
Power rating	400 mW	420 mW	530 mW	390 mVA / 350 mW	340 mW / 0.4 VA
Status indicator	Green LED	Green LED	Green LED	Green LED	Green LED
Protective circuit	Free-wheeling diode, Reverse polarity protection	Free-wheeling diode, Reverse polarity protection	Free-wheeling diode, Reverse polarity protection	Rectifier	Rectifier

Ordering data					
PUSH IN connection Type	TRP 5VDC 1CO 16A	TRP 12VDC 1CO 16A	TRP 24VDC 1CO 16A	TRP 24VUC 1CO 16A	TRP 48VUC 1CO 16A
Order No.	<b>2618130000</b>	<b>2618040000</b>	<b>2618100000</b>	<b>2617910000</b>	<b>2617960000</b>
Screw connection Type	TRS 5VDC 1CO 16A	TRS 12VDC 1CO 16A	TRS 24VDC 1CO 16A	TRS 24VUC 1CO 16A	TRS 48VUC 1CO 16A
Order No.	<b>1479650000</b>	<b>1479670000</b>	<b>1479680000</b>	<b>1479690000</b>	<b>1479700000</b>
Note					

**Ordering data**

	60 V UC	120 V UC	230 V UC	120 V AC RC	230 V AC RC
<b>Control side</b>					
Rated control voltage	60 V UC ± 10 %	120 V UC ± 10 %	230 V UC ± 5 %	120 V AC ± 10 %	230 V AC ± 5 %
Rated current AC / DC	8 mA / 6.1 mA	3.5 mA / 3.5 mA	4 mA / 4 mA	5.5 mA /	10 mA /
Power rating	480 mVA / 360 mW	420 mVA / 420 mW	920 mVA / 920 mW	0.6 VA	2.3 VA
Status indicator	Green LED	Green LED	Green LED	Green LED	Green LED
Protective circuit	Rectifier	Rectifier	Rectifier	Rectifier, RC element	Rectifier, RC element

Ordering data					
PUSH IN connection Type	TRP 60VUC 1CO 16A	TRP 120VUC 1CO 16A	TRP 230VUC 1CO 16A	TRP 120VAC RC 1CO 16A	TRP 230VAC RC 1CO 16A
Order No.	<b>2617970000</b>	<b>2618280000</b>	<b>2618260000</b>	<b>2618270000</b>	<b>2618190000</b>
Screw connection Type	TRS 60VUC 1CO 16A	TRS 120VUC 1CO 16A	TRS 230VUC 1CO 16A	TRS 120VAC RC 1CO 16A	TRS 230VAC RC 1CO 16A
Order No.	<b>1479710000</b>	<b>1479730000</b>	<b>1479740000</b>	<b>1479750000</b>	<b>1479760000</b>
Note					

1 CO contact

Variable-voltage input

- Space-saving, 12.8 mm wide
- 16 A AgNi contact
- Internal cross-connection of the output terminals
- PUSH IN and screw connection
- Multi-voltage input: 24...230 V UC in one module

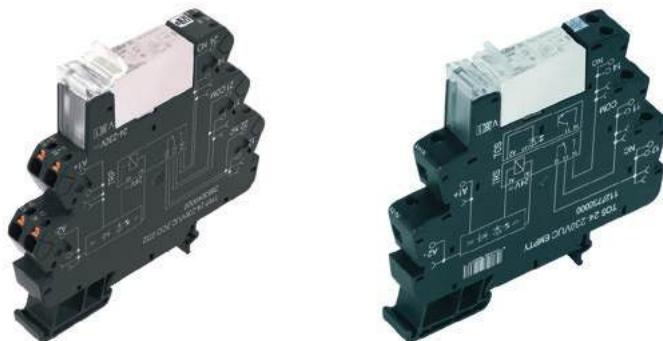

B

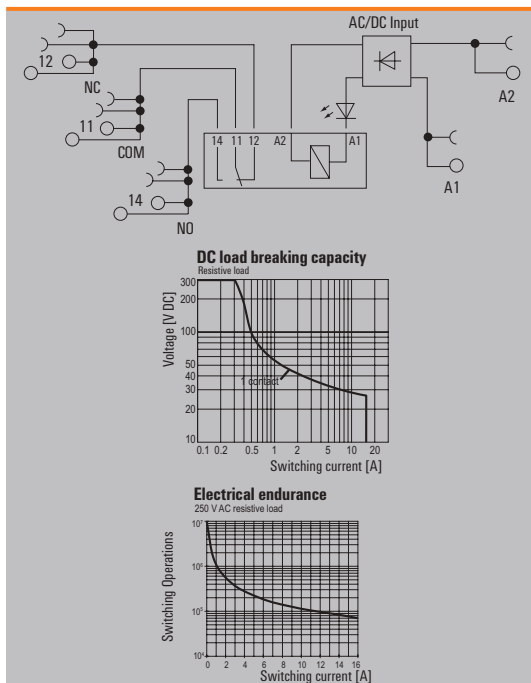

Technical data

Load side		
Rated switching voltage / Continuous current	250 V AC / 16 A	
Max. switching voltage, AC	250 V	
Inrush current	30 A / 4 s	
Min. switching power	10 mA @ 10 V, 100 mA @ 5 V	
Contact type	1 CO contact (AgNi)	
Mechanical service life	30 x 10 <sup>6</sup> switching cycles	
Max. switching frequency at rated load	0.1 Hz	
General data		
Ambient temperature (operational)	-40 °C...60 °C	
Storage temperature	-40 °C...85 °C	
Humidity	5-95% relative humidity, T <sub>0</sub> = 40°C, without condensation	
Approvals	CE; cULus; DETNORVER; UKCA	
Insulation coordinates		
Rated voltage	300 V	
Impulse withstand voltage		
Dielectric strength for control side - load side	3.51 kV <sub>eff</sub> / 1 min.	
Dielectric strength of neighbouring contacts		
Dielectric strength to mounting rail	3.51 kV <sub>eff</sub> / 1 min.	
Clearance and creepage distances for control side - load side	≥ 6 mm	
Overvoltage category	III	
Pollution degree	2	
Dimensions		
	<b>PUSH IN</b>	<b>Screw connection</b>
Clamping range (nominal / min. / max.)	mm <sup>2</sup> 1.5 / 0.14 / 2.5	1.5 / 0.14 / 2.5
Depth x width x height	mm 87.8 / 12.8 / 89.4	87.8 / 12.8 / 89.6
<b>Note</b>	Accessories and dimensional drawings: refer to the TERMSERIES Accessories page. Further approvals and technical data can be found at <a href="http://eshop.weidmuller.com">eshop.weidmuller.com</a>	

Ordering data

Control side	24 V - 230 V UC
Rated control voltage	24...230 V UC ± 10 %
Rated current AC / DC	23.5 mA @ 24 V AC, 4.5 mA @ 230 V AC / 22.5 mA @ 24 V DC, 2.0 mA @ 230 V DC
Power rating	540 mW @ 24 V DC, 460 mW @ 230 V DC, 565 mVA @ 24 V AC, 1.0 VA @ 230 V AC
Status indicator	Green LED
Protective circuit	Rectifier
Approvals	CE; cULus; DETNORVER; UKCA

Ordering data	
PUSH IN connection	Type TRP 24-230VUC 1CO 16A ED2
Order No.	<b>2663120000</b>
Screw connection	Type TRS 24-230VUC 1CO 16A ED2
Order No.	<b>2662960000</b>
Note	



1 NO contact, inrush power HC

- Space-saving, 12.8 mm wide
- 16 A AgSnO contact
- Internal cross-connection of the output terminals
- Especially for capacitive loads
- PUSH IN and screw connection
- Multi-voltage input: 24...230 V UC in one module

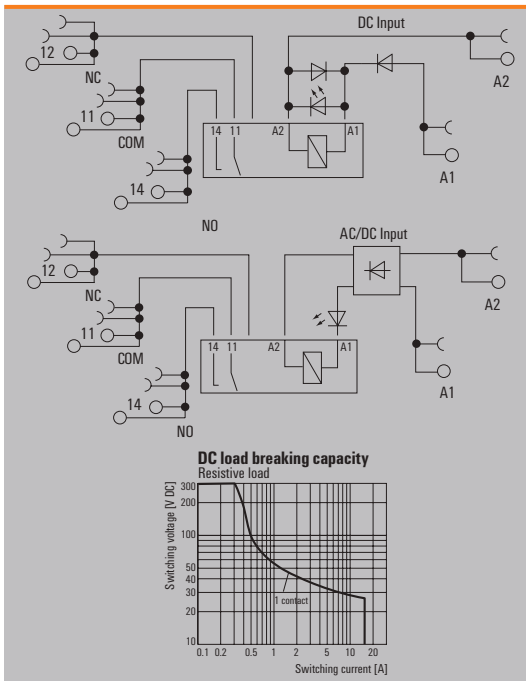
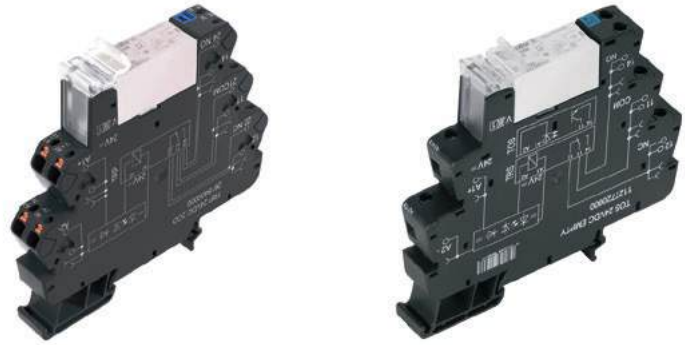

Technical data

Load side	
Rated switching voltage / Continuous current	250 V AC / 16 A
Max. switching voltage, AC	250 V
Inrush current	80 A / 20 ms
Min. switching power	1 W
Contact type	1 NO contact (AgSnO)
Mechanical service life	10 x 10 <sup>6</sup> switching cycles
Max. switching frequency at rated load	0.1 Hz
General data	
Ambient temperature (operational)	-40 °C...60 °C
Storage temperature	-40 °C...85 °C
Humidity	5-95% relative humidity, T <sub>0</sub> = 40°C, without condensation
Approvals	CE; cULus; DETNORVER; UKCA
Insulation coordinates	
Rated voltage	300 V
Impulse withstand voltage	
Dielectric strength for control side - load side	3.51 kV <sub>eff</sub> / 1 min.
Dielectric strength of neighbouring contacts	
Dielectric strength to mounting rail	3.51 kV <sub>eff</sub> / 1 min.
Clearance and creepage distances for control side - load side	≥ 6 mm
Overvoltage category	III
Pollution degree	2
Dimensions	
Clamping range (nominal / min. / max.)	mm <sup>2</sup> 1.5 / 0.14 / 2.5
Depth x width x height	mm 87.8 / 12.8 / 89.4
Note	
Accessories and dimensional drawings: refer to the TERMSERIES Accessories page. Further approvals and technical data can be found at <a href="http://eshop.weidmueller.com">eshop.weidmueller.com</a>	

Ordering data

Control side	24 V DC	24 - 230 V UC
Rated control voltage	24 V DC ± 20 %	24...230 V UC ± 10 %
Rated current AC / DC	/ 22.0 mA	23.5 mA @ 24 V AC, 4.5 mA @ 230 V AC / 22.5 mA @ 24 V DC, 2.0 mA @ 230 V DC
Power rating	530 mW	540 mW @ 24 V DC, 460 mW @ 230 V DC, 565 mVA @ 24 V AC, 1.0 VA @ 230 V AC
Status indicator	Green LED	Green LED
Protective circuit	Free-wheeling diode, Reverse polarity protection	Rectifier
Approvals	CE; cULus; DETNORVER; UKCA	CE; cULus; DETNORVER; UKCA

Ordering data		
PUSH IN connection Type	TRP 24VDC 1NO HC	TRP 24-230VUC 1NO HC ED2
Order No.	<b>2618090000</b>	<b>2663130000</b>
Screw connection Type	TRS 24VDC 1NO HC	TRS 24-230VUC 1NO HC ED2
Order No.	<b>1479780000</b>	<b>2662970000</b>
Note		

**1 NO contact, inrush power HCP**

- Space-saving, only 12.8 mm wide
- 16 A AgSnO contact + leading tungsten contact
- Internal cross-connection of the output terminals
- Especially for capacitive loads
- PUSH IN and screw connection
- Multi-voltage input: 24...230 V UC in one module

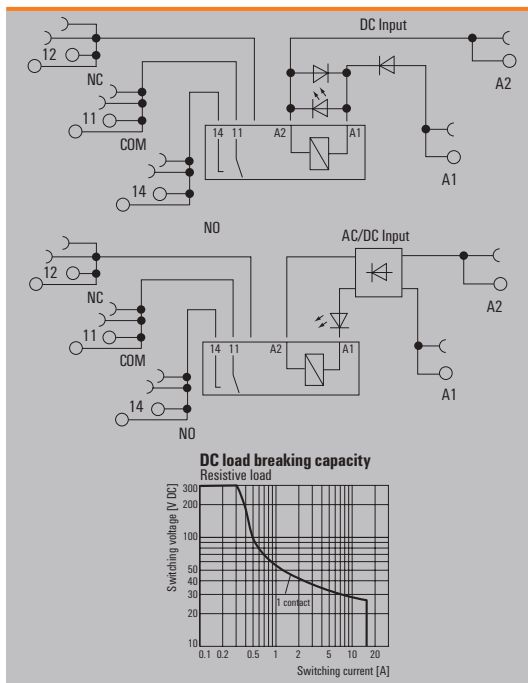
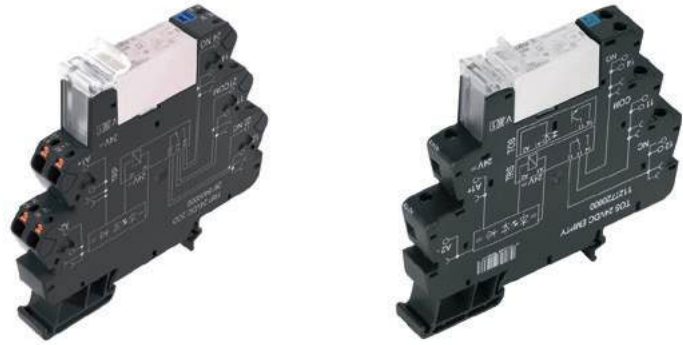

**Technical data**

Load side	
Rated switching voltage / Continuous current	250 V AC / 16 A
Max. switching voltage, AC	250 V
Inrush current	165 A / 20 ms, 800 A / 200 µs
Min. switching power	1 W
Contact type	1 NO contact (AgSnO + W)
Mechanical service life	5 x 10 <sup>6</sup> switching cycles
Max. switching frequency at rated load	0.1 Hz
General data	
Ambient temperature (operational)	-40 °C...60 °C
Storage temperature	-40 °C...85 °C
Humidity	5-95% relative humidity, T <sub>0</sub> = 40°C, without condensation
Approvals	CE; cULus; DETNORVER; UKCA
Insulation coordinates	
Rated voltage	300 V
Impulse withstand voltage	6 kV (1.2/50 µs)
Dielectric strength for control side - load side	1.2 kV <sub>eff</sub> / 5 s
Dielectric strength of neighbouring contacts	
Dielectric strength to mounting rail	4 kV <sub>eff</sub> / 1 Min.
Clearance and creepage distances for control side - load side	≥ 6 mm
Overvoltage category	III
Pollution degree	2
Dimensions	
Clamping range (nominal / min. / max.)	mm <sup>2</sup> 1.5 / 0.14 / 2.5
Depth x width x height	mm 87.8 / 12.8 / 89.4
Note	
Accessories and dimensional drawings: refer to the TERMSERIES Accessories page. Further approvals and technical data can be found at <a href="http://eshop.weidmueller.com">eshop.weidmueller.com</a>	

**Ordering data**

	24 V DC	24 V - 230 V UC
<b>Control side</b>		
Rated control voltage	24 V DC ± 20 %	24...230 V UC ± 10 %
Rated current AC / DC	/ 22.0 mA	23.5 mA @ 24 V AC, 4.5 mA @ 230 V AC / 22.5 mA @ 24 V DC, 2.0 mA @ 230 V DC
Power rating	530 mW	540 mW @ 24 V DC, 460 mW @ 230 V DC, 565 mVA @ 24 V AC, 1.0 VA @ 230 V AC
Status indicator	Green LED	Green LED
Protective circuit	Free-wheeling diode, Reverse polarity protection	Rectifier
Approvals	CE; cULus; DETNORVER; UKCA	CE; cULus; DETNORVER; UKCA

Ordering data		
PUSH IN connection Type	TRP 24VDC 1NO HCP	TRP 24-230VUC 1NO HCP ED2
Order No.	<b>2617930000</b>	<b>2663140000</b>
Screw connection Type	TRS 24VDC 1NO HCP	TRS 24-230VUC 1NO HCP ED2
Order No.	<b>1479810000</b>	<b>2662980000</b>
<b>Note</b>		

**2 CO contacts**

**AC/DC/UC coil**

- Space saving, just 12.8 mm modular width
- AgNi contact
- PUSH IN and screw connection

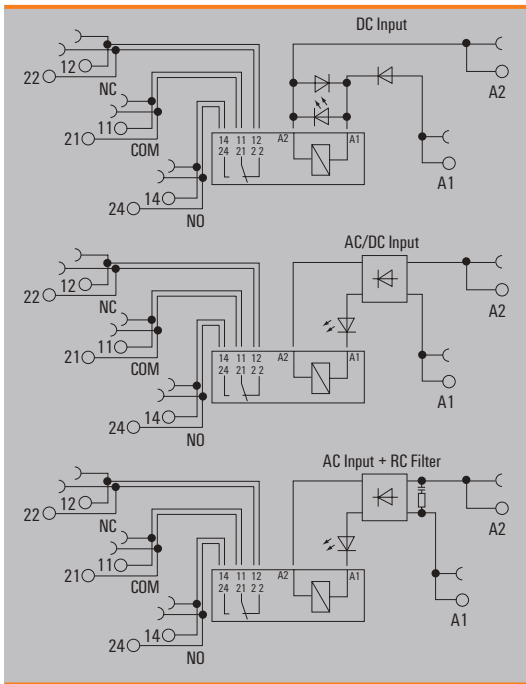

**Technical data**

Load side	
Rated switching voltage / Continuous current	250 V AC / 8 A
Max. switching voltage, AC	250 V
Inrush current	15 A / 4 s
Min. switching power	1 mA @ 24 V, 10 mA @ 10 V, 100 mA @ 5 V
Contact type	2 CO contact (AgNi)
Mechanical service life	30 x 10 <sup>6</sup> switching cycles
Max. switching frequency at rated load	0.1 Hz
General data	
Ambient temperature (operational)	-40 °C...60 °C
Storage temperature	-40 °C...85 °C
Humidity	5-95% relative humidity, T <sub>90</sub> = 40°C, without condensation
Approvals	CE; cULus; DETNORVER; UKCA
Insulation coordinates	
Rated voltage	300 V
Impulse withstand voltage	6 kV (1.2/50 µs)
Dielectric strength for control side - load side	3.51 kV <sub>eff</sub> / 1 min.
Dielectric strength of neighbouring contacts	2.5 kV <sub>eff</sub> / 1 Min.
Dielectric strength to mounting rail	4 kV <sub>eff</sub> / 1 Min.
Clearance and creepage distances for control side - load side	≥ 6 mm
Overvoltage category	III
Pollution degree	2

Dimensions	PUSH IN		Screw connection
Clamping range (nominal / min. / max.)	mm <sup>2</sup>	1.5 / 0.14 / 2.5	1.5 / 0.14 / 2.5
Depth x width x height	mm	87.8 / 12.8 / 89.4	87.8 / 12.8 / 89.6
<b>Note</b>	Accessories and dimensional drawings: refer to the TERMSERIES Accessories page. Further approvals and technical data can be found at <a href="http://eshop.weidmueller.com">eshop.weidmueller.com</a>		

**Applications**

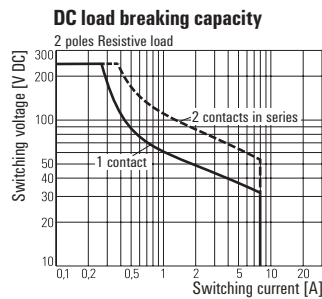
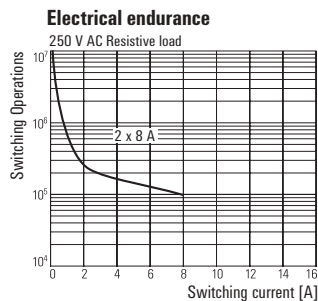

**2 CO contacts**  
**AC/DC/UC coil**

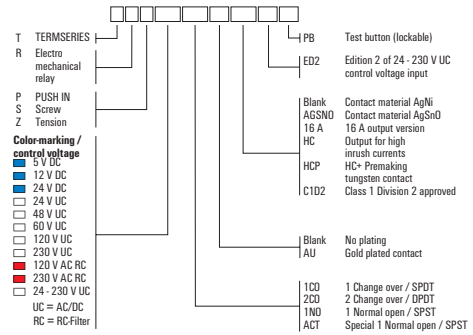

**Ordering data**

Control side	5 V DC	12 V DC	24 V DC	24 V UC	48 V UC
Rated control voltage	5 V DC ± 20 %	12 V DC ± 20 %	24 V DC ± 20 %	24 V UC ± 10 %	48 V UC ± 10 %
Rated current AC / DC	/ 70 mA	/ 33 mA	/ 20.5 mA	16 mA / 14 mA	9 mA / 7 mA
Power rating	400 mW	400 mW	495 mW	390 mVA / 350 mW	340 mW / 0.4 VA
Status indicator	Green LED	Green LED	Green LED	Green LED	Green LED
Protective circuit	Free-wheeling diode, Reverse polarity protection	Free-wheeling diode, Reverse polarity protection	Free-wheeling diode, Reverse polarity protection	Rectifier	Rectifier

Ordering data					
PUSH IN connection Type	TRP 5VDC 2CO	TRP 12VDC 2CO	TRP 24VDC 2CO	TRP 24VUC 2CO	TRP 48VUC 2CO
Order No.	<b>2614840000</b>	<b>2618550000</b>	<b>2618400000</b>	<b>2618320000</b>	<b>2618520000</b>
Screw connection Type	TRS 5VDC 2CO	TRS 12VDC 2CO	TRS 24VDC 2CO	TRS 24VUC 2CO	TRS 48VUC 2CO
Order No.	<b>1123470000</b>	<b>1123480000</b>	<b>1123490000</b>	<b>1123500000</b>	<b>1123510000</b>
Note					

**Ordering data**

Control side	60 V UC	120 V UC	230 V UC	120 V AC RC	230 V AC RC
Rated control voltage	60 V UC ± 10 %	120 V UC ± 10 %	230 V UC ± 5 %	120 V AC ± 10 %	230 V AC ± 5 %
Rated current AC / DC	8.3 mA / 6.0 mA	3.5 mA / 3.5 mA	5.5 mA / 4.4 mA	5.5 mA /	8.8 mA /
Power rating	360 mW, 500 mVA	420 mVA / 420 mW	1 W, 1.2 VA	0.6 VA	2.1 VA
Status indicator	Green LED	Green LED	Green LED	Green LED	Green LED
Protective circuit	Rectifier	Rectifier	Rectifier	Rectifier, RC element	Rectifier, RC element

Ordering data					
PUSH IN connection Type	TRP 60VUC 2CO	TRP 120VUC 2CO	TRP 230VUC 2CO	TRP 120VAC RC 2CO	TRP 230VAC RC 2CO
Order No.	<b>2618290000</b>	<b>2618570000</b>	<b>2618440000</b>	<b>2618470000</b>	<b>2618330000</b>
Screw connection Type	TRS 60VUC 2CO	TRS 120VUC 2CO	TRS 230VUC 2CO	TRS 120VAC RC 2CO	TRS 230VAC RC 2CO
Order No.	<b>1123520000</b>	<b>1123530000</b>	<b>1123540000</b>	<b>1123550000</b>	<b>1123570000</b>
Note					

**2 CO contacts**  
**multi-voltage input**

- Space saving, just 12.8 mm modular width
- AgNi contact
- PUSH IN and screw connection
- Multi-voltage input: 24...230 V UC in one module



**B**

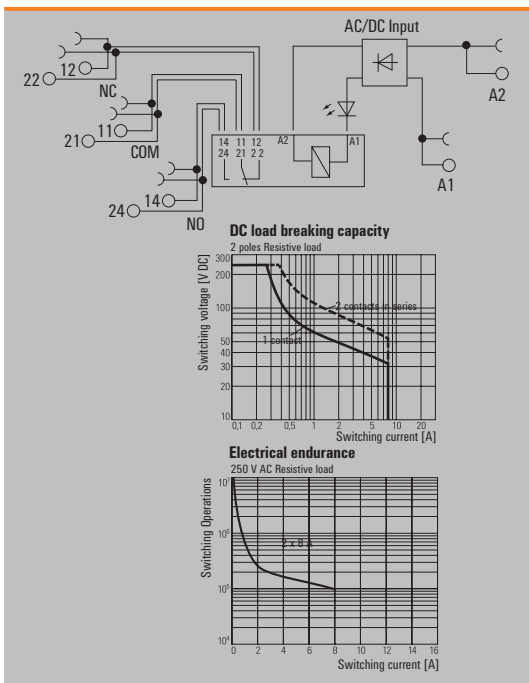

**Technical data**

Load side		
Rated switching voltage / Continuous current	250 V AC / 8 A	
Max. switching voltage, AC	250 V	
Inrush current	15 A / 4 s	
Min. switching power	1 mA @ 24 V, 10 mA @ 10 V, 100 mA @ 5 V	
Contact type	2 CO contact (AgNi)	
Mechanical service life	30 x 10 <sup>6</sup> switching cycles	
Max. switching frequency at rated load	0.1 Hz	
General data		
Ambient temperature (operational)	-40 °C...60 °C	
Storage temperature	-40 °C...85 °C	
Humidity	5-95% relative humidity, T <sub>0</sub> = 40°C, without condensation	
Approvals	CE; cULus; DETNORVER; UKCA	
Insulation coordinates		
Rated voltage	300 V	
Impulse withstand voltage	≥ 6 mm	
Dielectric strength for control side - load side	3.51 kV <sub>eff</sub> / 1 min.	
Dielectric strength of neighbouring contacts	3.51 kV <sub>eff</sub> / 1 min.	
Clearance and creepage distances for control side - load side	≥ 6 mm	
Overvoltage category	III	
Pollution degree	2	
Dimensions		
	<b>PUSH IN</b>	<b>Screw connection</b>
Clamping range (nominal / min. / max.)	mm <sup>2</sup> 1.5 / 0.14 / 2.5	1.5 / 0.14 / 2.5
Depth x width x height	mm 87.8 / 12.8 / 89.4	87.8 / 12.8 / 89.6
Note		
Accessories and dimensional drawings: refer to the TERMSERIES Accessories page. Further approvals and technical data can be found at <a href="http://eshop.weidmueller.com">eshop.weidmueller.com</a>		

**Ordering data**

Control side	
Rated control voltage	24...230 V UC ± 10 %
Rated current AC / DC	23.5 mA @ 24 V AC, 4.5 mA @ 230 V AC / 22.5 mA @ 24 V DC, 2.0 mA @ 230 V DC
Power rating	540 mW @ 24 V DC, 460 mW @ 230 V DC, 565 mVA @ 24 V AC, 1.0 VA @ 230 V AC
Status indicator	Green LED
Protective circuit	Rectifier
Approvals	CE; cULus; DETNORVER; UKCA

**24 V - 230 V UC**

Ordering data	
PUSH IN connection	Type TRP 24-230VUC 2CO ED2
Order No.	<b>2663040000</b>
Screw connection	Type TRS 24-230VUC 2CO ED2
Order No.	<b>2662880000</b>
Note	



**2 CO contact with hard gold-plated contacts**  
**AC/DC/UC coil**

- Space saving, just 12.8 mm modular width
- AgNi contact with gold plating
- PUSH IN and screw connection



**B**

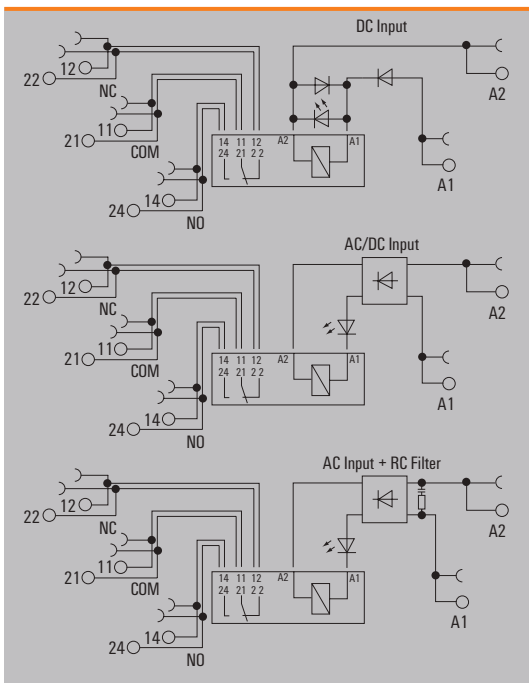

**Technical data**

Load side			
Rated switching voltage / Continuous current	250 V AC / 8 A		
Max. switching voltage, AC	250 V		
Inrush current	15 A / 4 s		
Min. switching power	1 mA @ 1 V		
Contact type	2 CO contact (AgNi gold-plated)		
Mechanical service life	30 x 10 <sup>6</sup> switching cycles		
Max. switching frequency at rated load	0.1 Hz		
General data			
Ambient temperature (operational)	-40 °C...60 °C		
Storage temperature	-40 °C...85 °C		
Humidity	5-95% relative humidity, T <sub>0</sub> = 40°C, without condensation		
Approvals	CE; cULus; DETNORVER; UKCA		
Insulation coordinates			
Rated voltage	300 V		
Impulse withstand voltage	6 kV (1.2/50 µs)		
Dielectric strength for control side - load side	3.51 kV <sub>eff</sub> / 1 min.		
Dielectric strength of neighbouring contacts	2.5 kV <sub>eff</sub> / 1 Min.		
Dielectric strength to mounting rail	4 kV <sub>eff</sub> / 1 Min.		
Clearance and creepage distances for control side - load side	≥ 6 mm		
Overvoltage category	III		
Pollution degree	2		
Dimensions			
Clamping range (nominal / min. / max.)	mm <sup>2</sup>	<b>PUSH IN</b>	<b>Screw connection</b>
		1.5 / 0.14 / 2.5	1.5 / 0.14 / 2.5
Depth x width x height	mm	87.8 / 12.8 / 89.4	87.8 / 12.8 / 89.6
Note			
Accessories and dimensional drawings: refer to the TERMSERIES Accessories page. Further approvals and technical data can be found at <a href="http://eshop.weidmueller.com">eshop.weidmueller.com</a>			

**Applications**

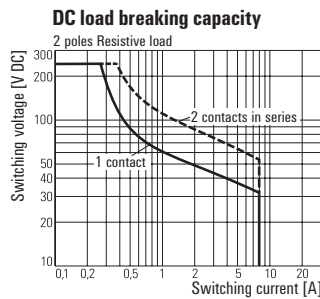
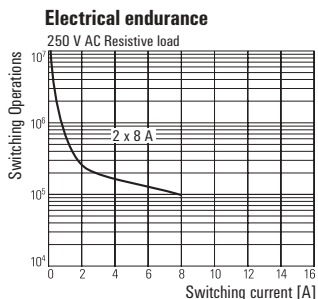

**2 CO contact with hard gold-plated contacts**  
**AC/DC/UC coil**

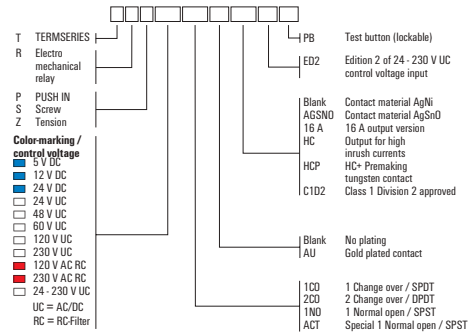

**Ordering data**

Control side	5 V DC	12 V DC	24 V DC	24 V UC	48 V UC
Rated control voltage	5 V DC ± 20 %	12 V DC ± 20 %	24 V DC ± 20 %	24 V UC ± 10 %	48 V UC ± 10 %
Rated current AC / DC	/ 70 mA	/ 33 mA	/ 20.5 mA	16 mA / 14 mA	9 mA / 7 mA
Power rating	400 mW	400 mW	495 mW	390 mVA / 350 mW	340 mW / 0.4 VA
Status indicator	Green LED	Green LED	Green LED	Green LED	Green LED
Protective circuit	Free-wheeling diode, Reverse polarity protection	Free-wheeling diode, Reverse polarity protection	Free-wheeling diode, Reverse polarity protection	Rectifier	Rectifier

Ordering data					
PUSH IN connection Type	TRP 5VDC 2CO AU	TRP 12VDC 2CO AU	TRP 24VDC 2CO AU	TRP 24VUC 2CO AU	TRP 48VUC 2CO AU
Order No.	<b>2618580000</b>	<b>2618310000</b>	<b>2618530000</b>	<b>2618540000</b>	<b>2618560000</b>
Screw connection Type	TRS 5VDC 2CO AU	TRS 12VDC 2CO AU	TRS 24VDC 2CO AU	TRS 24VUC 2CO AU	TRS 48VUC 2CO AU
Order No.	<b>1123710000</b>	<b>1123720000</b>	<b>1123730000</b>	<b>1123740000</b>	<b>1123750000</b>
Note					

**Ordering data**

Control side	60 V UC	120 V UC	230 V UC	120 V AC RC	230 V AC RC
Rated control voltage	60 V UC ± 10 %	120 V UC ± 10 %	230 V UC ± 5 %	120 V AC ± 10 %	230 V AC ± 5 %
Rated current AC / DC	8.3 mA / 6.0 mA	3.5 mA / 3.5 mA	5.5 mA / 4.4 mA	5.5 mA /	8.8 mA /
Power rating	360 mW, 500 mVA	420 mVA / 420 mW	1 W, 1.2 VA	0.6 VA	2.1 VA
Status indicator	Green LED	Green LED	Green LED	Green LED	Green LED
Protective circuit	Rectifier	Rectifier	Rectifier	Rectifier, RC element	Rectifier, RC element

Ordering data					
PUSH IN connection Type	TRP 60VUC 2CO AU	TRP 120VUC 2CO AU	TRP 230VUC 2CO AU	TRP 120VAC RC 2CO AU	TRP 230VAC RC 2CO AU
Order No.	<b>2618360000</b>	<b>2618590000</b>	<b>2618300000</b>	<b>2618490000</b>	<b>2618500000</b>
Screw connection Type	TRS 60VUC 2CO AU	TRS 120VUC 2CO AU	TRS 230VUC 2CO AU	TRS 120VAC RC 2CO AU	TRS 230VAC RC 2CO AU
Order No.	<b>1123770000</b>	<b>1123780000</b>	<b>1123790000</b>	<b>1123800000</b>	<b>1123810000</b>
Note					

**2 CO contact with hard gold-plated contacts  
multi-voltage input**

- Space saving, just 12.8 mm modular width
- AgNi contact
- PUSH IN and screw connection
- Multi-voltage input: 24...230 V UC in one module



B

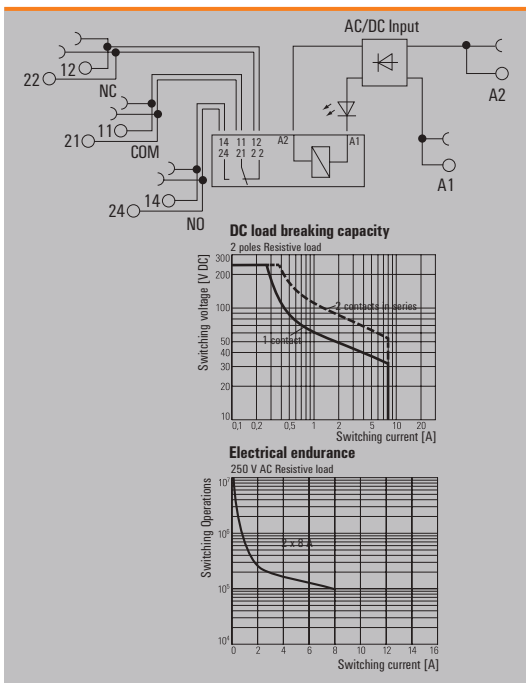

**Technical data**

Load side	
Rated switching voltage / Continuous current	250 V AC / 8 A
Max. switching voltage, AC	250 V
Inrush current	15 A / 4 s
Min. switching power	1 mA @ 1 V
Contact type	2 CO contact (AgNi gold-plated)
Mechanical service life	30 x 10 <sup>6</sup> switching cycles
Max. switching frequency at rated load	0.1 Hz
General data	
Ambient temperature (operational)	-40 °C...60 °C
Storage temperature	-40 °C...85 °C
Humidity	5-95% relative humidity, T <sub>0</sub> = 40°C, without condensation
Approvals	CE; cULus; DETNORVER; UKCA
Insulation coordinates	
Rated voltage	300 V
Impulse withstand voltage	
Dielectric strength for control side - load side	3.51 kV <sub>eff</sub> / 1 min.
Dielectric strength of neighbouring contacts	
Dielectric strength to mounting rail	3.51 kV <sub>eff</sub> / 1 min.
Clearance and creepage distances for control side - load side	≥ 6 mm
Overvoltage category	III
Pollution degree	2
Dimensions	
Clamping range (nominal / min. / max.)	mm <sup>2</sup> 1.5 / 0.14 / 2.5
Depth x width x height	mm 87.8 / 12.8 / 89.4
	mm 87.8 / 12.8 / 89.6
Note	
Accessories and dimensional drawings: refer to the TERMSERIES Accessories page. Further approvals and technical data can be found at <a href="http://eshop.weidmueller.com">eshop.weidmueller.com</a>	

**Ordering data**

Control side	
Rated control voltage	24...230 V UC ± 10 %
Rated current AC / DC	23.5 mA @ 24 V AC, 4.5 mA @ 230 V AC / 22.5 mA @ 24 V DC, 2.0 mA @ 230 V DC
Power rating	540 mW @ 24 V DC, 460 mW @ 230 V DC, 565 mVA @ 24 V AC, 1.0 VA @ 230 V AC
Status indicator	Green LED
Protective circuit	Rectifier
Approvals	CE; cULus; DETNORVER; UKCA

Ordering data	
PUSH IN connection	Type TRP 24-230VUC 2CO AU ED2
	Order No. <b>2663050000</b>
Screw connection	Type TRS 24-230VUC 2CO AU ED2
	Order No. <b>2662890000</b>
Note	



**2 CO AgNi**  
with test button

- Space-saving, only 12.8 mm wide
- AgNi contact
- For capacitive and inductive loads
- PUSH IN and screw connection
- With test button



**B**

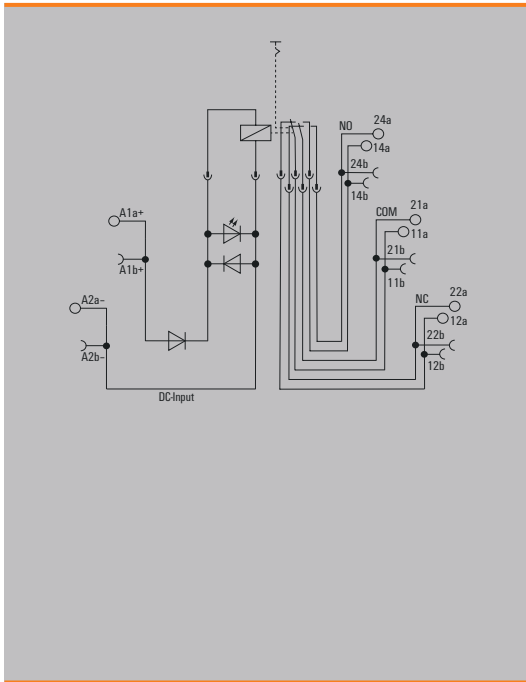

**Technical data**

Load side	
Rated switching voltage / Continuous current	250 V AC / 8 A
Max. switching voltage, AC	250 V
Inrush current	30 A / 4 s
Min. switching power	100 mA @ 10 V
Contact type	2 CO contact (AgNi)
Mechanical service life	5 x 10 <sup>6</sup> switching cycles
Max. switching frequency at rated load	0.1 Hz
General data	
Ambient temperature (operational)	-40 °C...60 °C
Storage temperature	-40 °C...70 °C
Humidity	5...85 % rel. humidity, no condensation
Approvals	CE; cULus
Insulation coordinates	
Rated voltage	300 V
Impulse withstand voltage	6 kV (1.2/50 µs)
Dielectric strength for control side - load side	2.5 kV <sub>eff</sub> / 1 Min.
Dielectric strength of neighbouring contacts	
Dielectric strength to mounting rail	4 kV <sub>eff</sub> / 1 Min.
Clearance and creepage distances for control side - load side	≥ 5.5 mm
Overvoltage category	III
Pollution degree	2

Dimensions		PUSH IN	Screw connection
Clamping range (nominal / min. / max.)	mm <sup>2</sup>	1.5 / 0.14 / 2.5	1.5 / 0.14 / 2.5
Depth x width x height	mm	97.5 / 12.8 / 89.4	97.5 / 12.8 / 89.6

**Note**

**2 CO AgNi**  
with test button

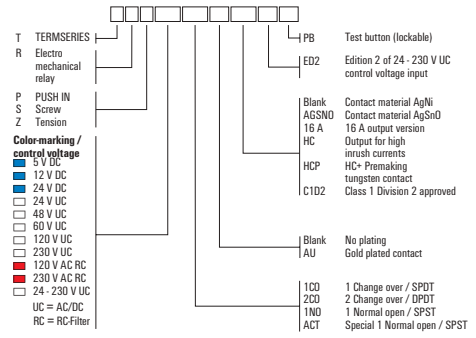

**Ordering data**

Control side	24 V DC	24 V UC	120 V UC	230 V UC
Rated control voltage	19.2 V...24 V...28.8 V DC ± 10 %	21.6 V...24 V...26.4 V UC ± 10 %	108 V...120 V...132 V UC ± 10 %	218.5 V...230 V...241.5 V UC ± 5 %
Rated current AC / DC	/ 16.7 mA	/ 16.7 mA	/ 4.3 mA	/ 4.3 mA
Power rating	495 mW	410 mW	456 mW	
Status indicator	Green LED	Green LED	Green LED	Green LED
Protective circuit	Free-wheeling diode, Reverse polarity protection	Free-wheeling diode, Reverse polarity protection	Free-wheeling diode, Reverse polarity protection	Free-wheeling diode, Reverse polarity protection

Ordering data				
Type	TRP 24VDC 2CO PB	TRP 24VUC 2CO PB	TRP 120VUC 2CO PB	TRP 230VUC 2CO PB
Order No.	<b>2988340000</b>	<b>2988350000</b>	<b>2988360000</b>	<b>2988370000</b>
Type	TRS 24VDC 2CO PB	TRS 24VUC 2CO PB	TRS 120VUC 2CO PB	TRS 230VUC 2CO PB
Order No.	<b>2988440000</b>	<b>2988450000</b>	<b>2988460000</b>	<b>2988470000</b>
Note				

**2 CO AgNi**  
with test button  
**Multi-voltage input**

- Space-saving, only 12.8 mm wide
- AgNi contact
- For capacitive and inductive loads
- PUSH IN and screw connection
- Multi-voltage input: 24...230 V UC in one module
- With test button

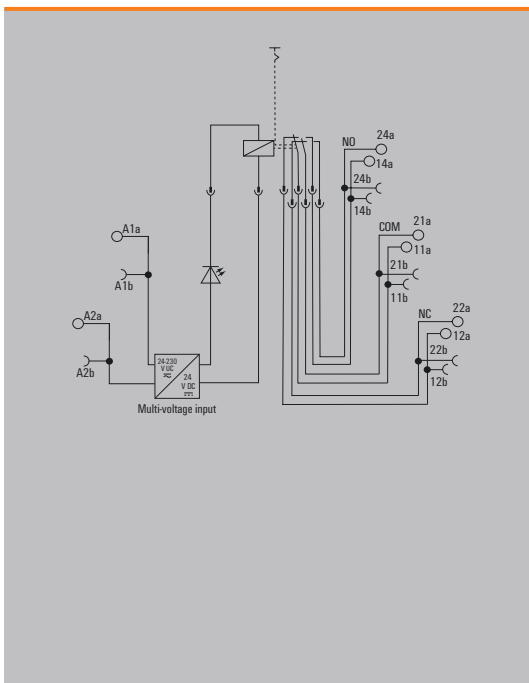

**Technical data**

Load side	
Rated switching voltage / Continuous current	250 V AC / 8 A
Max. switching voltage, AC	250 V
Inrush current	30 A / 4 s
Min. switching power	100 mA @ 10 V
Contact type	2 CO contact (AgNi)
Mechanical service life	5 x 10 <sup>6</sup> switching cycles
Max. switching frequency at rated load	0.1 Hz
General data	
Ambient temperature (operational)	-40 °C...60 °C
Storage temperature	-40 °C...70 °C
Humidity	5...85 % rel. humidity, no condensation
Approvals	CE; cULus
Insulation coordinates	
Rated voltage	300 V
Impulse withstand voltage	6 kV (1.2/50 µs)
Dielectric strength for control side - load side	2.5 kV <sub>eff</sub> / 1 Min.
Dielectric strength of neighbouring contacts	
Dielectric strength to mounting rail	4 kV <sub>eff</sub> / 1 Min.
Clearance and creepage distances for control side - load side	≥ 5.5 mm
Overvoltage category	III
Pollution degree	2

Dimensions	PUSH IN	Screw connection
Clamping range (nominal / min. / max.)	mm <sup>2</sup> 1.5 / 0.14 / 2.5	1.5 / 0.14 / 2.5
Depth x width x height	mm 97.5 / 12.8 / 89.4	97.5 / 12.8 / 89.6

**Note**

**Ordering data**

Control side	24 - 230 V UC
Rated control voltage	21.6...253 V UC ± 10 %
Rated current AC / DC	/ 16.7 mA
Power rating	600 mVA @ 24 V AC
Status indicator	Green LED
Protective circuit	Free-wheeling diode, Reverse polarity protection
Approvals	CE; cULus

Ordering data	
Type	TRP 24-230VUC 2CO ED2 PB
Order No.	<b>2988380000</b>
Type	TRS 24-230VUC 2CO ED2 PB
Order No.	<b>2988480000</b>

**Note**



## TERMSERIES TIMER – timer function

### Complete modules

- Space-saving, 6.4 mm wide
- 3 time functions
- Complete module with 1 CO relay (AgSnO)
- PUSH IN and screw connection

### TR T 24 V DC 1CO M3

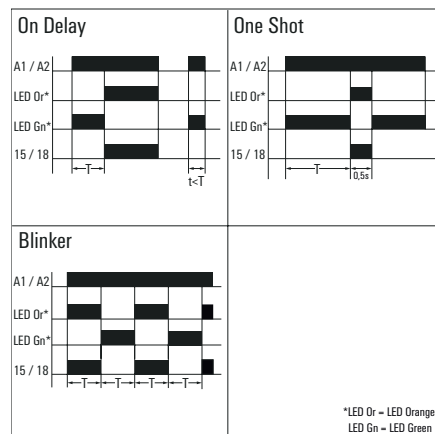
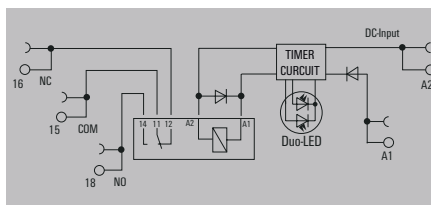
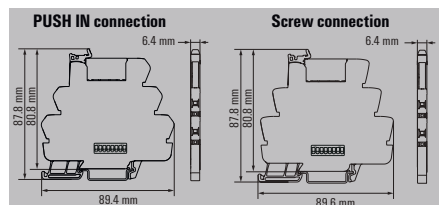

### Technical data

Control side	
Rated control voltage	24 V DC ± 20 %
Power rating	280 mW
Status indicator	Duo-LED orange: relay output on, Green duo-LED lit: supply voltage on, Green duo-LED flashes: incorrect configuration, no function
Repeat accuracy	± 1 %
Basic accuracy	≤ 5 % (of scale-end value)
Setting tolerance	5 %
Min. pulse duration	50 ms
Time ranges	0.01 s - 0.1 s, 0.1 s - 1 s, 1 s - 10 s, 10 s - 100 s
Max. reset time after voltage interruption	50
Load side	
Rated switching voltage	250 V AC
Max. switching voltage, AC	250 V
Max. switching voltage, DC	250 V
Continuous current	6 A
AC switching capacity (resistive), max.	1500 VA
DC switching capacity (resistive), max.	144 W @ 24 V
Max. switching frequency at rated load	0.1 Hz
Contact type	1 CO contact (AgSnO)
Mechanical service life	5 x 10 <sup>6</sup> switching cycles
General data	
Ambient temperature (operational)	-20 °C...60 °C
Storage temperature	-40 °C...85 °C
Humidity	5-95% relative humidity, T <sub>a</sub> = 40 °C, without condensation
Version	
Resistance to vibration EN 61812-1	
Approvals	CE; cULus; DETNORVER; UKCA
Insulation coordinates	
Rated voltage	250 V
Clearance and creepage distances for control side - load side	≥ 6 mm
Dielectric strength for control side - load side	4 kV <sub>eff</sub> / 1 Min.
Impulse withstand voltage	6 kV (1.2/50 μs)
Protection degree	IP20
Dimensions	
Clamping range (nominal / min. / max.)	mm <sup>2</sup>
Depth x width x height	mm
<b>Note</b>	

Type	Qty.	Order No.
TRS T 24VDC 1CO M3	10	2639560000
TRP T 24VDC 1CO M3	10	2639730000

### Ordering data

	Screw connection
	PUSH IN connection

### Note

Further approvals and technical data can be found at [eshop.weidmueller.com](http://eshop.weidmueller.com)

### Accessories

<b>Note</b>	Accessories: refer to the TERMSERIES Accessories page.
-------------	--

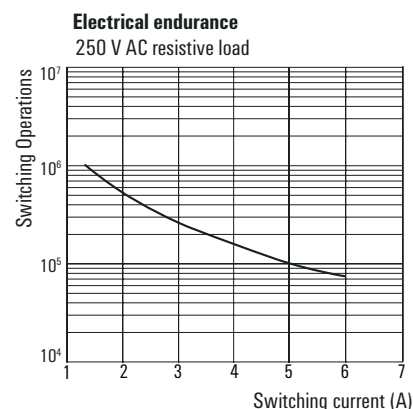
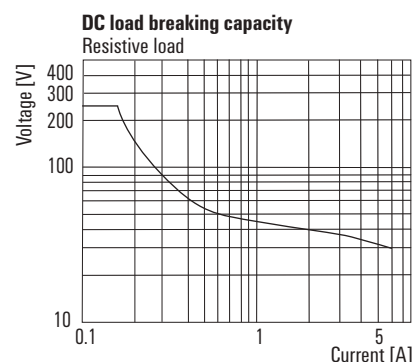

**Empty socket**

- Space-saving, 6.4 mm wide
- 3 time functions
- Empty sockets for electromechanical relays and solid-state relays
- PUSH IN and screw connection

**TR T 24 V DC 1CO M3 EMPTY**

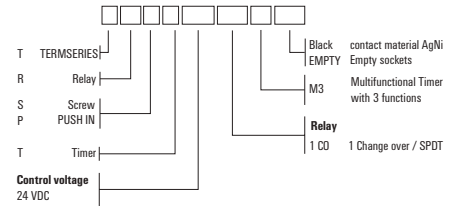
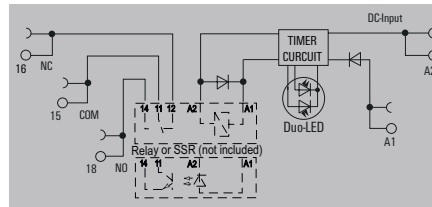
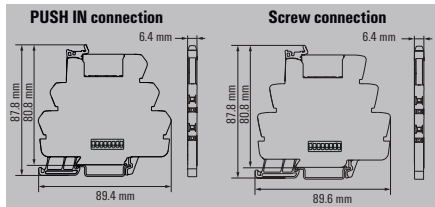

**Technical data**

**Control side**

Rated control voltage  
Power rating  
Status indicator

Repeat accuracy  
Basic accuracy  
Setting tolerance  
Min. pulse duration  
Time ranges  
Max. reset time after voltage interruption

**Load side**

Rated switching voltage  
Max. switching voltage, AC  
Max. switching voltage, DC  
Continuous current

**General data**

Ambient temperature (operational)  
Storage temperature  
Humidity  
Version  
Resistance to vibration EN 61812-1  
Approvals

**Insulation coordinates**

Rated voltage  
Clearance and creepage distances for control side - load side  
Dielectric strength for control side - load side  
Impulse withstand voltage  
Protection degree

**Dimensions**

Clamping range (nominal / min. / max.) mm<sup>2</sup>  
Depth x width x height mm

**Note**

**Ordering data**

Screw connection  
PUSH IN connection

**Note**

**Accessories**

**Note**

24 V DC ± 20 %

Duo-LED orange: relay output on, Green duo-LED lit: supply voltage on, Green duo-LED flashes: incorrect configuration, no function

± 1 %  
≤ 5% (of scale-end value)  
5 %  
50 ms  
0.01 s - 0.1 s, 0.1 s - 1 s, 1 s - 10 s, 10 s - 100 s  
50

250 V AC  
250 V  
250 V  
10 A

-20 °C...60 °C  
-40 °C...85 °C  
5-95% relative humidity, T<sub>a</sub> = 40°C, without condensation  
Empty socket

CE; cURus; DETNORVER; UKCA

250 V  
≥ 6 mm  
4 kV<sub>eff</sub> / 1 Min.  
6 kV (1.2/50 µs)  
IP20

PUSH IN connection	Screw connection
1.5 / 0.14 / 2.5	1.5 / 0.14 / 2.5
87.8 / 6.4 / 89.4	87.8 / 6.4 / 89.6

Type	Qty.	Order No.
TRS T 24VDC 1CO M3 EMPTY	10	2639720000
TRP T 24VDC 1CO M3 EMPTY	10	2639740000

Further approvals and technical data can be found at [eshop.weidmueller.com](http://eshop.weidmueller.com)

Accessories: refer to the TERMSERIES Accessories page.

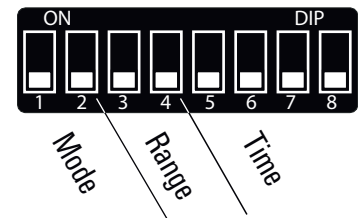

■ = On (DIP-switch turned to ON-position)

Mode	1	2
On Delay	■	■
One Shot	■	
Blinker		■

Range	3	4
10-100s	■	■
1-10s	■	
0.1-1s		■
10-100ms		

Time	5	6	7	8
0.1				
0.2				■
0.3			■	
0.4			■	■
0.5		■		
0.6		■	■	
0.7		■	■	
0.8		■	■	■
0.9	■			
1.0	■			■

**TERMSERIES FG**

- Complete module with relay
- Space-saving 12.8 mm width
  - AgNi contact
  - Bright shining status LED
  - With protective circuitry
  - PUSH IN and screw connection

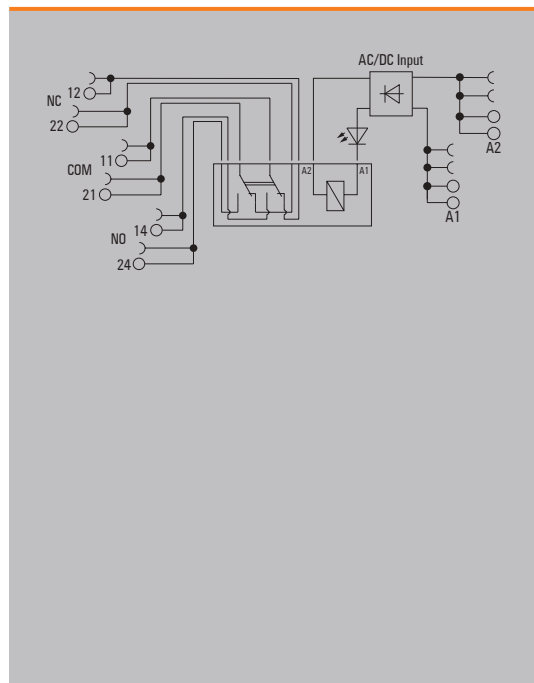

**Technical data**

Load side	
Rated switching voltage / Continuous current	250 V AC / 6 A
Max. switching voltage, AC	250 V
Inrush current	
Min. switching power	10 mA @ 5 V
Contact type	2 CO contacts forcibly guided (EN 61810-3 type B) (AgNi)
Mechanical service life	10 x 10 <sup>6</sup> switching cycles
Max. switching frequency at rated load	0.1 Hz
General data	
Ambient temperature (operational)	-25 °C...60 °C
Storage temperature	-25 °C...70 °C
Humidity	5...85 %, no condensation
Approvals	CE; cULus; UKCA
Insulation coordinates	
Rated voltage	300 V
Impulse withstand voltage	
Dielectric strength for control side - load side	3.51 kV <sub>eff</sub> / 1 min.
Dielectric strength of neighbouring contacts	2.21 kV <sub>eff</sub> / 1 min.
Dielectric strength to mounting rail	3.51 kV <sub>eff</sub> / 1 min.
Clearance and creep distances for control side - load side	≥ 6 mm
Overvoltage category	III
Pollution degree	2
Dimensions	
Clamping range (nominal / min. / max.)	mm <sup>2</sup> 1.5 / 0.14 / 2.5
Depth x width x height	mm 97.5 / 12.8 / 89.6
Note	
Accessories and dimensional drawings: refer to the TERMSERIES Accessories page. Further approvals and technical data can be found at <a href="http://eshop.weidmueller.com">eshop.weidmueller.com</a>	

**Applications**

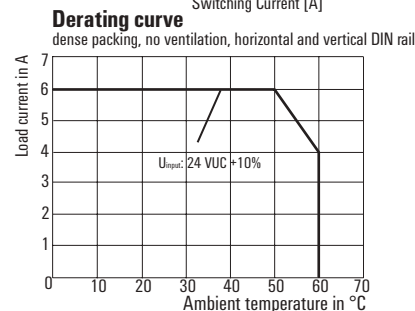
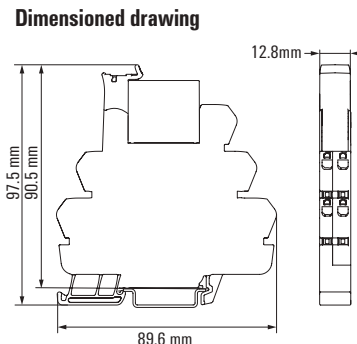
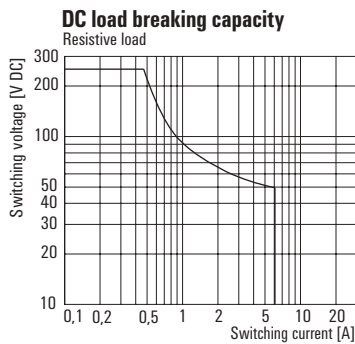
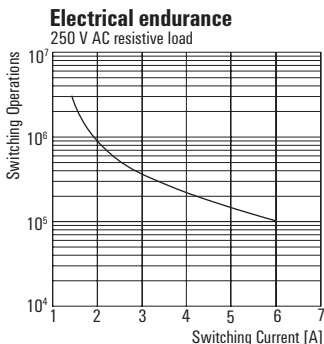

TERMSERIES FG

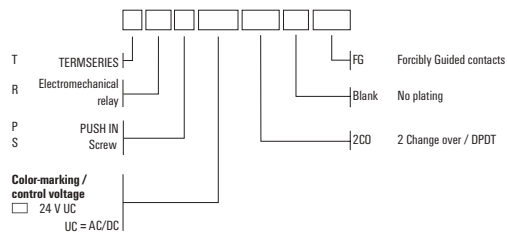

Ordering data

Control side		24 V UC
Rated control voltage		24 V UC ±10 %
Rated current AC / DC		24.4 mA / 23.5 mA
Power rating		585 mVA, 565 mW
Status indicator		Green LED
Protective circuit		Rectifier

Ordering data		
PUSH IN connection	Type	TRP 24VUC 2CO FG
	Order No.	<b>2706430000</b>
Screw connection	Type	TRS 24VUC 2CO FG
	Order No.	<b>2706290000</b>

Ordering data		
Spare relay	Type	RCH424024FG
	Order No.	<b>2723360000</b>

Note		

**Solid-state relay, 3...48 V DC / 100 mA**

**Output versions**

- Space saving, just 6.4 mm modular width
- 100 mA DC Output current
- PUSH IN and screw connection

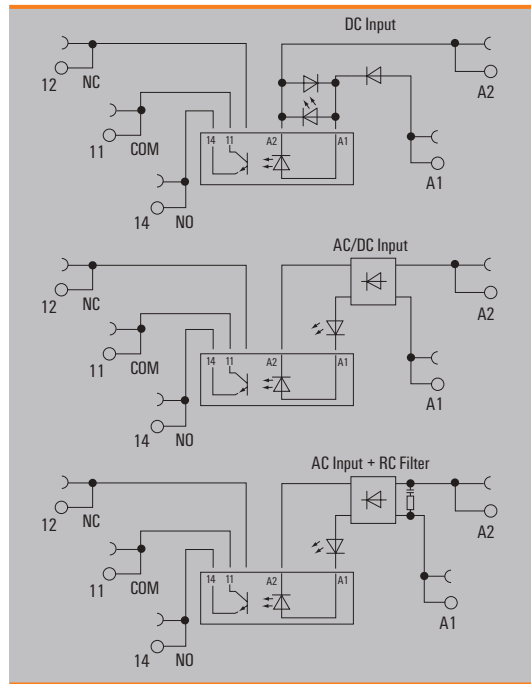
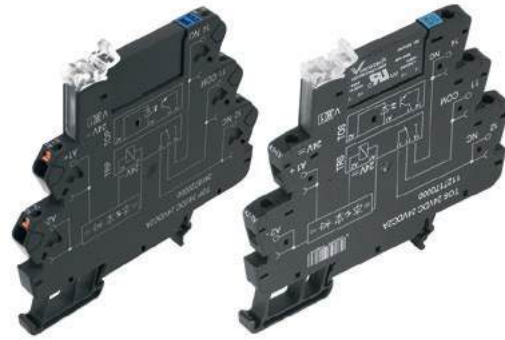

**Technical data**

Load side	
Rated switching voltage	3... 48 V DC
Continuous current	0.1 A
Inrush current	
Contact type	1 NO contact (Bipolar transistor)
Voltage drop at max. load	≤ 1 V
Leakage current	<10 µA
Short-circuit-proof / Protective circuit, load side	No / Free-wheeling diode

General data	
Ambient temperature (operational)	-20 °C...60 °C
Storage temperature	-40 °C...70 °C
Humidity	5-95% relative humidity, T <sub>90</sub> = 40°C, without condensation
Approvals	CE; cULus; DETNORVER; UKCA

Insulation coordinates	
Rated voltage	300 V
Impulse withstand voltage	6 kV (1.2/50 µs)
Dielectric strength for control side - load side	2.5 kV <sub>eff</sub>
Dielectric strength to mounting rail	4 kV <sub>eff</sub> / 1 Min.
Clearance and creepage distances for control side - load side	≥ 5.5 mm
Overvoltage category	III
Pollution degree	2

Dimensions	PUSH IN connection	Screw connection
Clamping range (nominal / min. / max.)	mm <sup>2</sup> 1.5 / 0.14 / 2.5	1.5 / 0.14 / 2.5
Depth x width x height	mm 87.8 / 6.4 / 89.4	87.8 / 6.4 / 89.6

**Note** Accessories and dimensional drawings: refer to the TERMSERIES Accessories page. Further approvals and technical data can be found at [eshop.weidmueller.com](http://eshop.weidmueller.com)

Solid-state relay, 3...48 V DC / 100 mA

Output versions

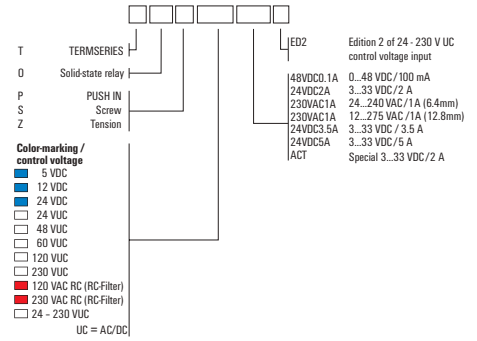

Ordering data

Control side	5 V DC	12 V DC	24 V DC	24 V UC	48 V UC
Rated control voltage	5 V DC $\pm 20\%$	12 V DC $\pm 20\%$	24 V DC $\pm 20\%$	24 V UC $\pm 10\%$	48 V UC $\pm 10\%$
Nominal control current	7 mA DC ( $\pm 20\%$ )	5 mA DC ( $\pm 20\%$ )	10 mA DC $\pm 20\%$	10 mA AC $\pm 20\%$ , 6 mA DC ( $\pm 20\%$ )	8 mA AC ( $\pm 20\%$ ), 7 mA DC ( $\pm 20\%$ )
Power rating	35 mW	112 mW	280 mW	154 mW	290 mVA / 192 mW
max. switching frequency (DC control voltage)	10 Hz	10 Hz	300 Hz	100 Hz	100 Hz
max. switching frequency (AC control voltage)				3 Hz	3 Hz
Status indicator	Green LED	Green LED	Green LED	Green LED	Green LED
Protective circuit	Free-wheeling diode, Reverse polarity protection	Rectifier	Free-wheeling diode, Reverse polarity protection	Rectifier	Rectifier

Ordering data					
PUSH IN connection Type	TOP 5VDC 48VDC0.1A	TOP 12VDC 48VDC0.1A	TOP 24VDC 48VDC0.1A	TOP 24VUC 48VDC0.1A	TOP 48VUC 48VDC0.1A
Order No.	<b>2614860000</b>	<b>2618600000</b>	<b>2618790000</b>	<b>2618640000</b>	<b>2618710000</b>
Screw connection Type	TOS 5VDC 48VDC0.1A	TOS 12VDC 48VDC0.1A	TOS 24VDC 48VDC0.1A	TOS 24VUC 48VDC0.1A	TOS 48VUC 48VDC0.1A
Order No.	<b>1126920000</b>	<b>1126930000</b>	<b>1126940000</b>	<b>1126950000</b>	<b>1126960000</b>
Note					

Ordering data

Control side	60 V UC	120 V UC	230 V UC	120 V AC RC	230 V AC RC
Rated control voltage	60 V UC $\pm 10\%$	120 V UC $\pm 10\%$	230 V UC $\pm 10\%$	120 V AC $\pm 10\%$	230 V AC $\pm 10\%$
Nominal control current	4.8 mA AC ( $\pm 10\%$ ), 2.5 mA DC ( $\pm 10\%$ )	5 mA AC ( $\pm 30\%$ ), 3 mA DC ( $\pm 30\%$ )	3.5 mA AC ( $\pm 5\%$ ), 2.9 mA DC ( $\pm 5\%$ )	7 mA AC ( $\pm 20\%$ )	9 mA AC
Power rating	150 mW, 290 mVA	0.48 VA	670 mW, 805 mVA	0.84 VA	1.9 VA
max. switching frequency (DC control voltage)	10 Hz	3 Hz	3 Hz		
max. switching frequency (AC control voltage)	3 Hz	3 Hz	3 Hz	3 Hz	3 Hz
Status indicator	Green LED	Green LED	Green LED	Green LED	Green LED
Protective circuit	Rectifier	Rectifier	Rectifier	Rectifier, RC element	Rectifier, RC element

Ordering data					
PUSH IN connection Type	TOP 60VUC 48VDC0.1A	TOP 120VUC 48VDC0.1A	TOP 230VUC 48VDC0.1A	TOP 120VAC RC 48VDC0.1A	TOP 230VAC RC 48VDC0.1A
Order No.	<b>2614880000</b>	<b>2618680000</b>	<b>2618690000</b>	<b>2618650000</b>	<b>2618620000</b>
Screw connection Type	TOS 60VUC 48VDC0.1A	TOS 120VUC 48VDC0.1A	TOS 230VUC 48VDC0.1A	TOS 120VAC RC 48VDC0.1A	TOS 230VAC RC 48VDC0.1A
Order No.	<b>1126970000</b>	<b>1126980000</b>	<b>1126990000</b>	<b>1127000000</b>	<b>1127010000</b>
Note					

**Solid-state relay, 3...48 V DC / 100 mA**

**Output versions, multi-voltage input**

- Space saving, just 6.4 mm modular width
- 100 mA DC Output current
- PUSH IN and screw connection
- Multi-voltage input: 24...230 V UC in one module

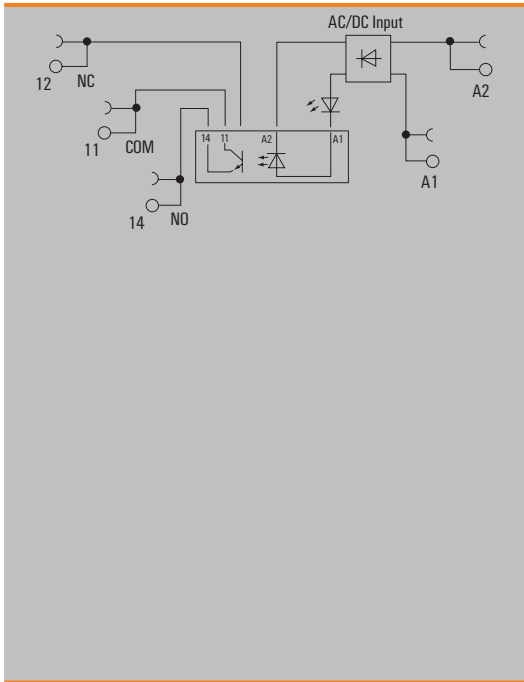

**Technical data**

Load side		
Rated switching voltage	3... 48 V DC	
Continuous current	0.1 A	
Inrush current		
Contact type	1 NO contact (Bipolar transistor)	
Voltage drop at max. load	≤ 1 V	
Leakage current	<10 µA	
Short-circuit-proof / Protective circuit, load side	No / Free-wheeling diode	
General data		
Ambient temperature (operational)	-20 °C...60 °C	
Storage temperature	-40 °C...70 °C	
Humidity	5-95% relative humidity, T <sub>0</sub> = 40°C, without condensation	
Insulation coordinates		
Rated voltage	300 V	
Impulse withstand voltage	6 kV (1.2/50 µs)	
Dielectric strength for control side - load side	3.51 kV <sub>eff</sub> / 1 min.	
Dielectric strength to mounting rail	3.51 kV <sub>eff</sub> / 1 min.	
Clearance and creepage distances for control side - load side	≥ 6 mm	
Overvoltage category	III	
Pollution degree	2	
Dimensions		
	<b>PUSH IN connection</b>	<b>Screw connection</b>
Clamping range (nominal / min. / max.)	mm <sup>2</sup> 1.5 / 0.14 / 2.5	1.5 / 0.14 / 2.5
Depth x width x height	mm 87.8 / 6.4 / 89.4	87.8 / 6.4 / 89.6
<b>Note</b>	Accessories and dimensional drawings: refer to the TERMSERIES Accessories page. Further approvals and technical data can be found at <a href="http://eshop.weidmueller.com">eshop.weidmueller.com</a>	

**Ordering data**

Control side	
Rated control voltage	24...230 V UC ±10 %
Nominal control current	11.0 mA at 24 V DC, 1.1 mA at 230 V DC, 19.0 mA at 24 V AC, 2.8 mA at 230 V AC
Power rating	265 mW @ 24 V DC, 255 mW @ 230 V DC, 455 mVA @ 24 V AC, 645 mVA @ 230 V AC
max. switching frequency (DC control voltage)	3 Hz
max. switching frequency (AC control voltage)	3 Hz
Status indicator	Green LED
Protective circuit	Rectifier
Approvals	CE; cULus; DETNORVER; UKCA

Ordering data	
PUSH IN connection	Type TOP 24-230VUC 48VDC0,1A ED2
Order No.	<b>2663070000</b>
Screw connection	Type TOS 24-230VUC 48VDC0,1A ED2
Order No.	<b>2662910000</b>

Note	

**24 V - 230 V UC**



**Solid-state relay, 3...33 V DC / 2 A**

**Output versions**

- Space saving, just 6.4 mm modular width
- 2 A DC Output current
- PUSH IN and screw connection

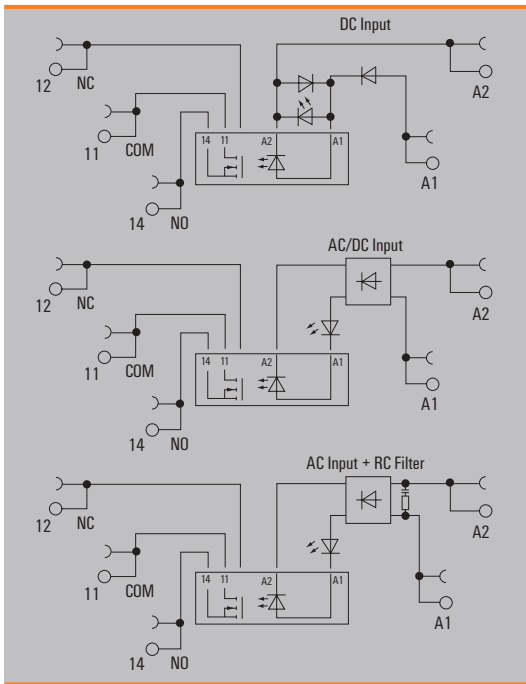

**Technical data**

Load side	
Rated switching voltage	3...33 V DC
Continuous current	2 A
Inrush current	15 A / 10 ms
Contact type	1 NO contact (MOS-FET)
Voltage drop at max. load	≤ 120 mV
Leakage current	<10 µA
Short-circuit-proof / Protective circuit, load side	No / Free-wheeling diode, Reverse polarity protection

General data	
Ambient temperature (operational)	-20 °C...60 °C
Storage temperature	-40 °C...70 °C
Humidity	5-95% relative humidity, T <sub>0</sub> = 40°C, without condensation
Approvals	CE; cULus; DETNORVER; UKCA

Insulation coordinates	
Rated voltage	300 V
Impulse withstand voltage	6 kV (1.2/50 µs)
Dielectric strength for control side - load side	2.5 kV <sub>eff</sub>
Dielectric strength to mounting rail	4 kV <sub>eff</sub> / 1 Min.
Clearance and creepage distances for control side - load side	≥ 5.5 mm
Overvoltage category	III
Pollution degree	2

Dimensions	PUSH IN connection	Screw connection
Clamping range (nominal / min. / max.)	mm <sup>2</sup> 1.5 / 0.14 / 2.5	1.5 / 0.14 / 2.5
Depth x width x height	mm 87.8 / 6.4 / 89.4	87.8 / 6.4 / 89.6

**Note** Accessories and dimensional drawings: refer to the TERMSERIES Accessories page. Further approvals and technical data can be found at [eshop.weidmueller.com](http://eshop.weidmueller.com)

Solid-state relay, 3...33 V DC / 2 A

Output versions

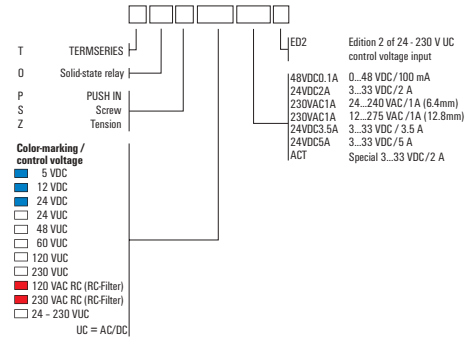

Ordering data

Control side	5 V DC	12 V DC	24 V DC	24 V UC	48 V UC
Rated control voltage	5 V DC $\pm 20\%$	12 V DC $\pm 20\%$	24 V DC $\pm 20\%$	24 V UC $\pm 10\%$	48 V UC $\pm 10\%$
Nominal control current	11.5 mA DC ( $\pm 20\%$ )	9.6 mA DC ( $\pm 20\%$ )	11.5 mA DC ( $\pm 10\%$ )	10 mA AC $\pm 20\%$ , 6 mA DC ( $\pm 20\%$ )	8 mA AC ( $\pm 20\%$ ), 7 mA DC ( $\pm 20\%$ )
Power rating	50 mW	112 mW	280 mW	154 mW	290 mVA / 192 mW
max. switching frequency (DC control voltage)	300 Hz	300 Hz	300 Hz	10 Hz	10 Hz
max. switching frequency (AC control voltage)				3 Hz	3 Hz
Status indicator	Green LED	Green LED	Green LED	Green LED	Green LED
Protective circuit	Free-wheeling diode, Reverse polarity protection	Free-wheeling diode, Reverse polarity protection	Free-wheeling diode, Reverse polarity protection	Rectifier	Rectifier

Ordering data

PUSH IN connection	Type	TOP 5VDC 24VDC2A	TOP 12VDC 24VDC2A	TOP 24VDC 24VDC2A	TOP 24VUC 24VDC2A	TOP 48VUC 24VDC2A
	Order No.	<b>2618810000</b>	<b>2618820000</b>	<b>2618720000</b>	<b>2618730000</b>	<b>2618760000</b>
Screw connection	Type	TOS 5VDC 24VDC2A	TOS 12VDC 24VDC2A	TOS 24VDC 24VDC2A	TOS 24VUC 24VDC2A	TOS 48VUC 24VDC2A
	Order No.	<b>1127140000</b>	<b>1127150000</b>	<b>1127170000</b>	<b>1127180000</b>	<b>1127190000</b>

Note

Ordering data

Control side	60 V UC	120 V UC	230 V UC	120 V AC RC	230 V AC RC
Rated control voltage	60 V UC $\pm 10\%$	120 V UC $\pm 10\%$	230 V UC $\pm 10\%$	120 V AC $\pm 10\%$	230 V AC $\pm 10\%$
Nominal control current	4.8 mA AC ( $\pm 10\%$ ), 2.5 mA DC ( $\pm 10\%$ )	4.1 mA AC ( $\pm 10\%$ ), 2.6 mA DC ( $\pm 10\%$ )	3.5 mA AC ( $\pm 5\%$ ), 2.9 mA DC ( $\pm 5\%$ )	7 mA AC ( $\pm 20\%$ )	9 mA AC
Power rating	150 mW, 290 mVA	0.49 VA, 0.31 W	670 mW, 805 mVA	0.84 VA	1.9 VA
max. switching frequency (DC control voltage)	10 Hz	10 Hz	3 Hz		
max. switching frequency (AC control voltage)	3 Hz	10 Hz	3 Hz	3 Hz	3 Hz
Status indicator	Green LED	Green LED	Green LED	Green LED	Green LED
Protective circuit	Rectifier	Rectifier	Rectifier	RC element	RC element

Ordering data

PUSH IN connection	Type	TOP 60VUC 24VDC2A	TOP 120VUC 24VDC2A	TOP 230VUC 24VDC2A	TOP 120VAC RC 24VDC2A	TOP 230VAC RC 24VDC2A
	Order No.	<b>2618970000</b>	<b>2618770000</b>	<b>2618800000</b>	<b>2618660000</b>	<b>2618670000</b>
Screw connection	Type	TOS 60VUC 24VDC2A	TOS 120VUC 24VDC2A	TOS 230VUC 24VDC2A	TOS 120VAC RC 24VDC2A	TOS 230VAC RC 24VDC2A
	Order No.	<b>1127200000</b>	<b>1127210000</b>	<b>1127220000</b>	<b>1127230000</b>	<b>1127240000</b>

Note

**Solid-state relay, 3...33 V DC / 2 A**

**Output versions, multi-voltage input**

- Space saving, just 6.4 mm modular width
- 2 A DC Output current
- PUSH IN and screw connection
- Multi-voltage input: 24...230 V UC in one module

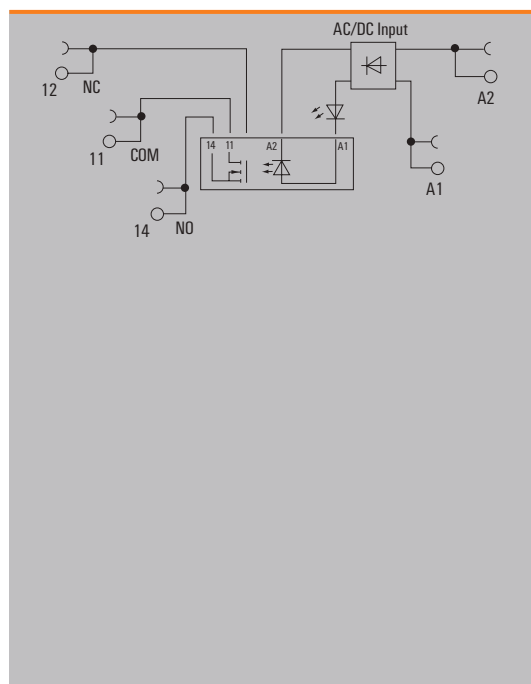

**Technical data**

Load side		
Rated switching voltage	3...33 V DC	
Continuous current	2 A	
Inrush current	15 A / 10 ms	
Contact type	1 NO contact (MOS-FET)	
Voltage drop at max. load	≤ 120 mV	
Leakage current	<10 µA	
Short-circuit-proof / Protective circuit, load side	No / Free-wheeling diode	
General data		
Ambient temperature (operational)	-20 °C...60 °C	
Storage temperature	-40 °C...70 °C	
Humidity	5-95% relative humidity, T <sub>0</sub> = 40°C, without condensation	
Insulation coordinates		
Rated voltage	300 V	
Impulse withstand voltage	6 kV (1.2/50 µs)	
Dielectric strength for control side - load side	3.51 kV <sub>eff</sub> / 1 min.	
Dielectric strength to mounting rail	3.51 kV <sub>eff</sub> / 1 min.	
Clearance and creepage distances for control side - load side	≥ 6 mm	
Overvoltage category	III	
Pollution degree	2	
Dimensions		
	<b>PUSH IN connection</b>	<b>Screw connection</b>
Clamping range (nominal / min. / max.)	mm <sup>2</sup> 1.5 / 0.14 / 2.5	1.5 / 0.14 / 2.5
Depth x width x height	mm 87.8 / 6.4 / 89.4	87.8 / 6.4 / 89.6
<b>Note</b>	Accessories and dimensional drawings: refer to the TERMSERIES Accessories page. Further approvals and technical data can be found at <a href="http://eshop.weidmueller.com">eshop.weidmueller.com</a>	

**Ordering data**

Control side	
Rated control voltage	24...230 V UC ±10 %
Nominal control current	11.0 mA at 24 V DC, 1.1 mA at 230 V DC, 19.0 mA at 24 V AC, 2.8 mA at 230 V AC
Power rating	265 mW @ 24 V DC, 255 mW @ 230 V DC, 455 mVA @ 24 V AC, 645 mVA @ 230 V AC
max. switching frequency (DC control voltage)	3 Hz
max. switching frequency (AC control voltage)	3 Hz
Status indicator	Green LED
Protective circuit	Rectifier
Approvals	CE; cULus; DETNORVER; UKCA

**24 V - 230 V UC**

Ordering data	
PUSH IN connection	Type TOP 24-230VUC 24VDC2A ED2
Order No.	<b>2663080000</b>
Screw connection	Type TOS 24-230VUC 24VDC2A ED2
Order No.	<b>2662920000</b>
<b>Note</b>	

**Solid-state relay, 3...33 V DC / 2 A actuator versions**

- Space-saving, only 6.4 mm wide
- AgNi contact
- PUSH IN and screw connection
- 24 V DC actuator version:  
Bridgeable, potential-free connection in the output (CC)

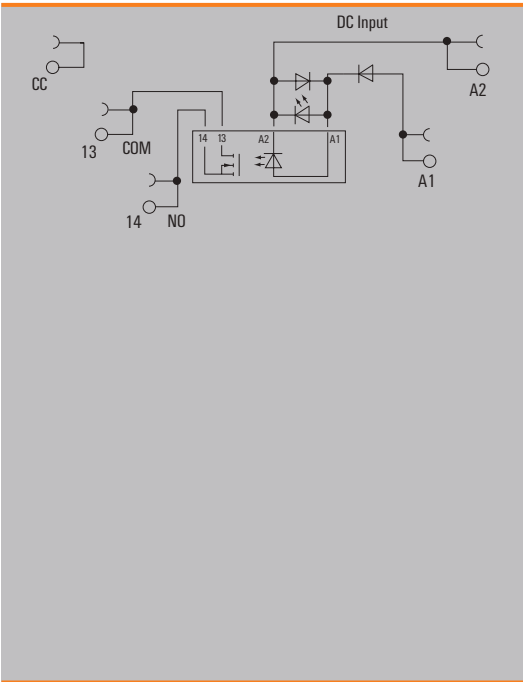

**Technical data**

Load side		
Rated switching voltage	3...33 V DC	
Continuous current	2 A	
Inrush current	15 A / 10 ms	
Contact type	1 NO contact (MOS-FET)	
Voltage drop at max. load	≤ 120 mV	
Leakage current	<10 µA	
Short-circuit-proof / Protective circuit, load side	No / Free-wheeling diode	
General data		
Ambient temperature (operational)	-20 °C...60 °C	
Storage temperature	-40 °C...70 °C	
Humidity	5-95% relative humidity, T <sub>0</sub> = 40°C, without condensation	
Approvals	CE; cULus; DETNORVER; UKCA	
Insulation coordinates		
Rated voltage	300 V	
Impulse withstand voltage	6 kV (1.2/50 µs)	
Dielectric strength for control side - load side	2.5 kV <sub>eff</sub>	
Dielectric strength to mounting rail	4 kV <sub>eff</sub> / 1 Min.	
Clearance and creepage distances for control side - load side	≥ 5.5 mm	
Overvoltage category	III	
Pollution degree	2	
Dimensions		
	<b>PUSH IN connection</b>	<b>Screw connection</b>
Clamping range (nominal / min. / max.)	mm <sup>2</sup> 1.5 / 0.14 / 2.5	1.5 / 0.14 / 2.5
Depth x width x height	mm 87.8 / 6.4 / 89.4	87.8 / 6.4 / 89.6
<b>Note</b>	Accessories and dimensional drawings: refer to the TERMSERIES Accessories page. Further approvals and technical data can be found at <a href="http://eshop.weidmueller.com">eshop.weidmueller.com</a>	

**Ordering data**

Control side		24 V DC
Rated control voltage		24 V DC ±20 %
Nominal control current		11.5 mA DC (±10 %)
Power rating		280 mW
max. switching frequency (DC control voltage)		300 Hz
max. switching frequency (AC control voltage)		
Status indicator		Green LED
Protective circuit		Free-wheeling diode, Reverse polarity protection

Ordering data		
PUSH IN connection	Type	TOP 24VDC ACT
	Order No.	<b>2618750000</b>
Screw connection	Type	TOS 24VDC ACT
	Order No.	<b>1391680000</b>
<b>Note</b>		

**Solid-state relay, 24...230 V AC / 1 A**

**Output versions**

- Space saving, just 6.4 mm modular width
- 1 A AC Output current
- PUSH IN and screw connection

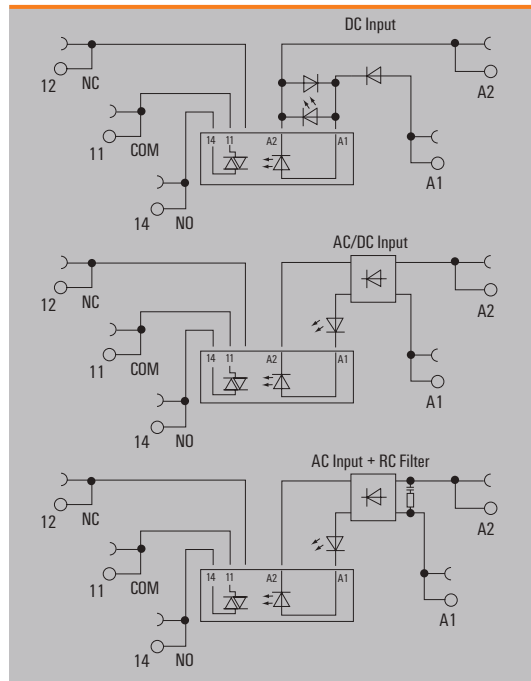
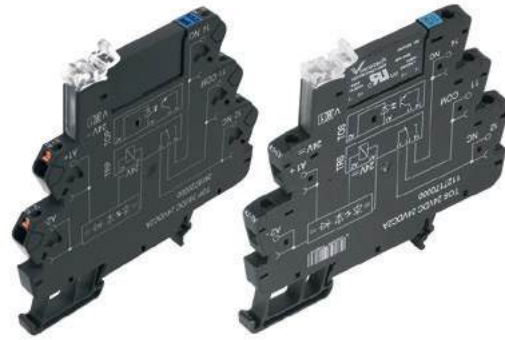

**Technical data**

Load side	
Rated switching voltage	24...240 V AC
Continuous current	1 A
Inrush current	15 A / 10 ms
Contact type	1 NO contact (Triac (zero-cross switch))
Voltage drop at max. load	≤ 1.6 V
Leakage current	<1.5 mA
Short-circuit-proof / Protective circuit, load side	No / RC element

General data	
Ambient temperature (operational)	-20 °C...60 °C
Storage temperature	-40 °C...70 °C
Humidity	5-95% relative humidity, T <sub>0</sub> = 40°C, without condensation
Approvals	CE; cULus; DETNORVER; UKCA

Insulation coordinates	
Rated voltage	300 V
Impulse withstand voltage	6 kV (1.2/50 µs)
Dielectric strength for control side - load side	2.5 kV <sub>eff</sub>
Dielectric strength to mounting rail	4 kV <sub>eff</sub> / 1 Min.
Clearance and creepage distances for control side - load side	≥ 5.5 mm
Overvoltage category	III
Pollution degree	2

Dimensions	PUSH IN connection	Screw connection
Clamping range (nominal / min. / max.)	mm <sup>2</sup> 1.5 / 0.14 / 2.5	1.5 / 0.14 / 2.5
Depth x width x height	mm 87.8 / 6.4 / 89.4	87.8 / 6.4 / 89.6

**Note** Accessories and dimensional drawings: refer to the TERMSERIES Accessories page. Further approvals and technical data can be found at [eshop.weidmueller.com](http://eshop.weidmueller.com)

Solid-state relay, 24...230 V AC / 1 A

Output versions

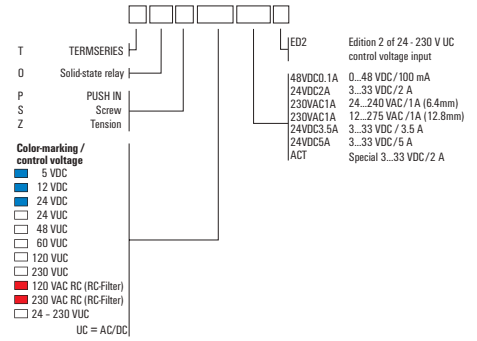

Ordering data

Control side	5 V DC	12 V DC	24 V DC	24 V UC	48 V UC
Rated control voltage	5 V DC $\pm 20\%$	12 V DC $\pm 20\%$	24 V DC $\pm 20\%$	24 V UC $\pm 10\%$	48 V UC $\pm 10\%$
Nominal control current	15 mA DC ( $\pm 20\%$ )	9.6 mA DC ( $\pm 20\%$ )	11.5 mA DC ( $\pm 10\%$ )	10 mA AC $\pm 20\%$ , 6 mA DC ( $\pm 20\%$ )	6 mA AC ( $\pm 20\%$ ), 4 mA DC ( $\pm 20\%$ )
Power rating	75 mW	112 mW	280 mW	154 mW	290 mVA / 192 mW
max. switching frequency (DC control voltage)	3 Hz	3 Hz	3 Hz	3 Hz	3 Hz
max. switching frequency (AC control voltage)				3 Hz	3 Hz
Status indicator	Green LED	Green LED	Green LED	Green LED	Green LED
Protective circuit	Free-wheeling diode, Reverse polarity protection	Free-wheeling diode, Reverse polarity protection	Free-wheeling diode, Reverse polarity protection	Rectifier	Rectifier

Ordering data

PUSH IN connection	Type	TOP 5VDC 230VAC1A	TOP 12VDC 230VAC1A	TOP 24VDC 230VAC1A	TOP 24VUC 230VAC1A	TOP 48VUC 230VAC1A
	Order No.	<b>2614850000</b>	<b>2618380000</b>	<b>2618420000</b>	<b>2618350000</b>	<b>2618460000</b>
Screw connection	Type	TOS 5VDC 230VAC1A	TOS 12VDC 230VAC1A	TOS 24VDC 230VAC1A	TOS 24VUC 230VAC1A	TOS 48VUC 230VAC1A
	Order No.	<b>1127390000</b>	<b>1127400000</b>	<b>1127410000</b>	<b>1127420000</b>	<b>1127430000</b>

Note

Ordering data

Control side	60 V UC	120 V UC	230 V UC	120 V AC RC	230 V AC RC
Rated control voltage	60 V UC $\pm 10\%$	120 V UC $\pm 10\%$	230 V UC $+5\% / -10\%$	120 V AC $\pm 10\%$	230 V AC $+5\% / -10\%$
Nominal control current	4.8 mA AC ( $\pm 10\%$ ), 2.5 mA DC ( $\pm 10\%$ )	5 mA AC ( $\pm 30\%$ ), 3 mA DC ( $\pm 30\%$ )	3.5 mA AC ( $\pm 5\%$ ), 2.9 mA DC ( $\pm 5\%$ )	7 mA AC ( $\pm 20\%$ )	8.3 mA AC ( $\pm 5\%$ )
Power rating	<300 mW	0.48 VA	0.8 VA / 660 mW	0.84 VA	2.1 VA
max. switching frequency (DC control voltage)	3 Hz	3 Hz	3 Hz	3 Hz	3 Hz
max. switching frequency (AC control voltage)	3 Hz	3 Hz	3 Hz	3 Hz	3 Hz
Status indicator	Green LED	Green LED	Green LED	Green LED	Green LED
Protective circuit	Rectifier	Rectifier	Rectifier	RC element	RC element

Ordering data

PUSH IN connection	Type	TOP 60VUC 230VAC1A	TOP 120VUC 230VAC1A	TOP 230VUC 230VAC1A	TOP 120VAC RC 230VAC1A	TOP 230VAC RC 230VAC1A
	Order No.	<b>2618370000</b>	<b>2618480000</b>	<b>2618450000</b>	<b>2618390000</b>	<b>2618430000</b>
Screw connection	Type	TOS 60VUC 230VAC1A	TOS 120VUC 230VAC1A	TOS 230VUC 230VAC1A	TOS 120VAC RC 230VAC1A	TOS 230VAC RC 230VAC1A
	Order No.	<b>1127440000</b>	<b>1127450000</b>	<b>1127470000</b>	<b>1127480000</b>	<b>1127490000</b>

Note

**Solid-state relay, 24 - 230 V AC / 1 A**

**Output versions, multi-voltage input**

- Space saving, just 6.4 mm modular width
- 1 A AC Output current
- PUSH IN and screw connection
- Multi-voltage input: 24...230 V UC in one module

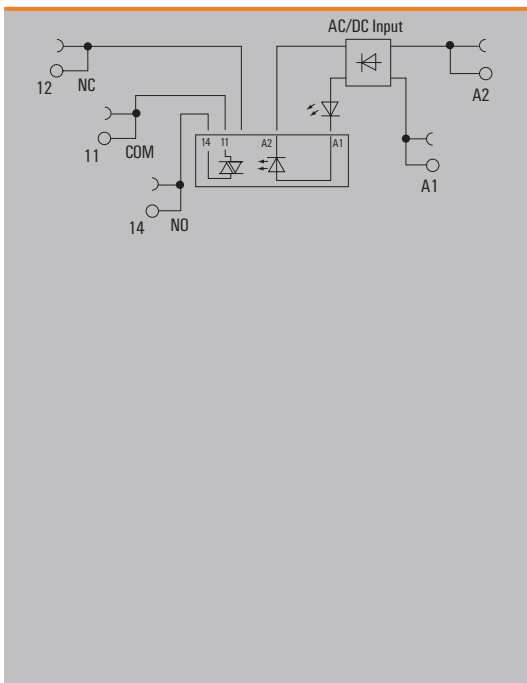

**Technical data**

Load side		
Rated switching voltage	24...240 V AC	
Continuous current	1 A	
Inrush current	15 A / 10 ms	
Contact type	1 NO contact (Triac (zero-cross switch))	
Voltage drop at max. load	≤ 1 V	
Leakage current	<1.5 mA	
Short-circuit-proof / Protective circuit, load side	No / RC element	
General data		
Ambient temperature (operational)	-20 °C...60 °C	
Storage temperature	-40 °C...70 °C	
Humidity	5-95% relative humidity, T <sub>0</sub> = 40°C, without condensation	
Insulation coordinates		
Rated voltage	300 V	
Impulse withstand voltage	6 kV (1.2/50 µs)	
Dielectric strength for control side - load side	3.51 kV <sub>eff</sub> / 1 min.	
Dielectric strength to mounting rail	3.51 kV <sub>eff</sub> / 1 min.	
Clearance and creepage distances for control side - load side	≥ 6 mm	
Overvoltage category	III	
Pollution degree	2	
Dimensions		
	<b>PUSH IN connection</b>	<b>Screw connection</b>
Clamping range (nominal / min. / max.)	mm <sup>2</sup> 1.5 / 0.14 / 2.5	1.5 / 0.14 / 2.5
Depth x width x height	mm 87.8 / 6.4 / 89.4	87.8 / 6.4 / 89.6
<b>Note</b>	Accessories and dimensional drawings: refer to the TERMSERIES Accessories page. Further approvals and technical data can be found at <a href="http://eshop.weidmueller.com">eshop.weidmueller.com</a>	

**Ordering data**

Control side	
Rated control voltage	24...230 V UC ±10 %
Nominal control current	11.0 mA at 24 V DC, 1.1 mA at 230 V DC, 19.0 mA at 24 V AC, 2.8 mA at 230 V AC
Power rating	265 mW @ 24 V DC, 255 mW @ 230 V DC, 455 mVA @ 24 V AC, 645 mVA @ 230 V AC
max. switching frequency (DC control voltage)	3 Hz
max. switching frequency (AC control voltage)	3 Hz
Status indicator	Green LED
Protective circuit	Rectifier
Approvals	CE; cULus; DETNORVER; UKCA

**24 V - 230 V UC**

Ordering data	
PUSH IN connection	Type TOP 24-230VUC 230VAC1A ED2
Order No.	<b>2663090000</b>
Screw connection	Type TOS 24-230VUC 230VAC1A ED2
Order No.	<b>2662930000</b>

Note	



**Solid-state relay, 0...33 V DC / 3.5 A**

**Output versions**

- Space saving, just 12.8 mm modular width
- 3.5 A DC Output current
- Internal cross connection of the output terminals
- PUSH IN and screw connection
- Multi-voltage input: 24...230 V UC in one module

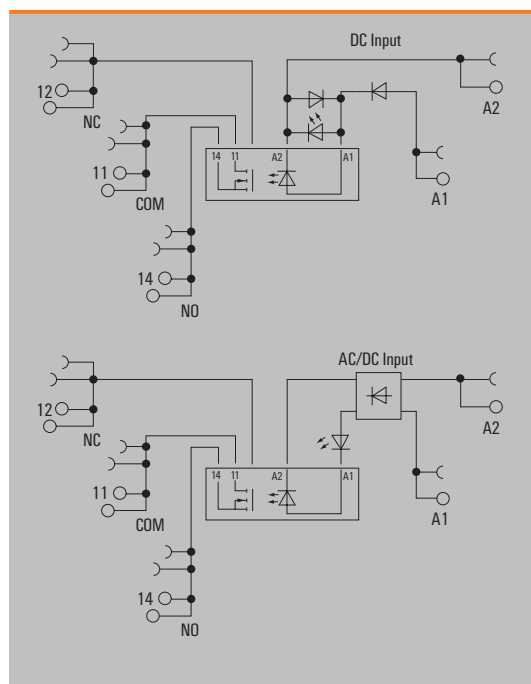

**Technical data**

Load side	
Rated switching voltage	3...33 V DC
Continuous current	3.5 A
Inrush current	
Contact type	1 NO contact (MOS-FET)
Voltage drop at max. load	≤ 0.3 V
Leakage current	<10 µA
Short-circuit-proof / Protective circuit, load side	No / Free-wheeling diode
General data	
Ambient temperature (operational)	-20 °C...60 °C
Storage temperature	-40 °C...70 °C
Humidity	5-95% relative humidity, T <sub>0</sub> = 40°C, without condensation
Insulation coordinates	
Rated voltage	300 V
Impulse withstand voltage	6 kV (1.2/50 µs)
Dielectric strength for control side - load side	2.5 kV <sub>eff</sub>
Dielectric strength to mounting rail	4 kV <sub>eff</sub> / 1 Min.
Clearance and creepage distances for control side - load side	≥ 5.5 mm
Overvoltage category	III
Pollution degree	2
Dimensions	
Clamping range (nominal / min. / max.)	mm <sup>2</sup> 1.5 / 0.14 / 2.5
Depth x width x height	mm 87.8 / 12.8 / 89.4
Note	
Accessories and dimensional drawings: refer to the TERMSERIES Accessories page. Further approvals and technical data can be found at <a href="http://eshop.weidmueller.com">eshop.weidmueller.com</a>	

**Ordering data**

	24 V DC	24 V - 230 V UC
<b>Control side</b>		
Rated control voltage	24 V DC ±20 %	24...230 V UC ±10 %
Nominal control current	10 mA DC ±20 %	12.0 mA at 24 V DC, 1.1 mA at 230 V DC, 20.0 mA at 24 V AC, 3.0 mA at 230 V AC
Power rating	240 mW	290 mW @ 24 V DC, 255 mW @ 230 V DC, 480 mVA @ 24 V AC, 690 mVA @ 230 V AC
max. switching frequency (DC control voltage)	300 Hz	3 Hz
max. switching frequency (AC control voltage)		3 Hz
Status indicator	Green LED	Green LED
Protective circuit	Free-wheeling diode, Reverse polarity protection	Rectifier
Approvals	CE; cULus; DETNORVER; UKCA	CE; cULus; DETNORVER; UKCA

Ordering data			
PUSH IN connection	Type	TOP 24VDC 24VDC3.5A	TOP 24-230VUC 24VDC3.5A ED2
	Order No.	<b>2618700000</b>	<b>2663100000</b>
Screw connection	Type	TOS 24VDC 24VDC3.5A	TOS 24-230VUC 24VDC3.5A ED2
	Order No.	<b>1127630000</b>	<b>2662940000</b>
<b>Note</b>			

**Solid-state relay, 0...33 VDC / 5 A**

**Output versions**

- Space-saving, 12.8 mm wide
- 5 A DC output current
- Internal cross-connection of the output terminals
- PUSH IN and screw connection
- Multi-voltage input: 24...230 V UC in one module

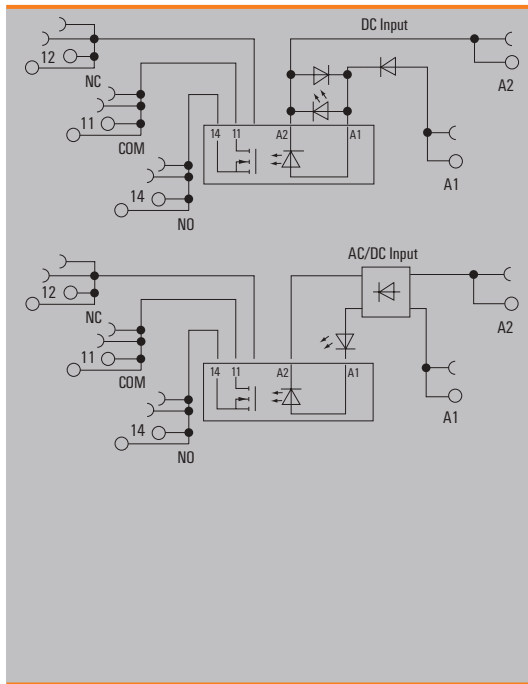

**Technical data**

Load side		
Rated switching voltage	3...33 V DC	
Continuous current	5 A	
Inrush current	15 A / 10 ms	
Contact type	1 NO contact (MOS-FET)	
Voltage drop at max. load	≤ 0.3 V	
Leakage current	<10 µA	
Short-circuit-proof / Protective circuit, load side	No / Free-wheeling diode	
General data		
Ambient temperature (operational)	-20 °C...60 °C	
Storage temperature	-40 °C...70 °C	
Humidity	5-95% relative humidity, T <sub>0</sub> = 40 °C, without condensation	
Insulation coordinates		
Rated voltage	300 V	
Impulse withstand voltage	6 kV (1.2/50 µs)	
Dielectric strength for control side - load side	2.5 kV <sub>eff</sub>	
Dielectric strength to mounting rail	4 kV <sub>eff</sub> / 1 Min.	
Clearance and creepage distances for control side - load side	≥ 5.5 mm	
Overtoltage category	III	
Pollution degree	2	
Dimensions		
	<b>PUSH IN connection</b>	<b>Screw connection</b>
Clamping range (nominal / min. / max.)	mm <sup>2</sup> 1.5 / 0.14 / 2.5	1.5 / 0.14 / 2.5
Depth x width x height	mm 87.8 / 12.8 / 89.4	87.8 / 12.8 / 89.6
<b>Note</b>	Accessories and dimensional drawings: refer to the TERMSERIES Accessories page. Further approvals and technical data can be found at <a href="http://eshop.weidmueller.com">eshop.weidmueller.com</a>	

**Ordering data**

	24 V DC	24 V - 230 V UC
<b>Control side</b>		
Rated control voltage	24 V DC ±20 %	24...230 V UC ±10 %
Nominal control current	10.8 mA DC (±10 %)	9.5 mA at 24 V DC, 1.1 mA at 230 V DC, 18 mA at 24 V AC, 3.0 mA at 230 V AC
Power rating	260 mW	230 mW @ 24 V DC, 255 mW @ 230 V DC, 430 mVA @ 24 V AC, 690 mVA @ 230 V AC
max. switching frequency (DC control voltage)	300 Hz	3 Hz
max. switching frequency (AC control voltage)		3 Hz
Status indicator	Green LED	Green LED
Protective circuit	Free-wheeling diode, Reverse polarity protection	Rectifier
Approvals	CE; cULus; DETNORVER; UKCA	CE; cULus; DETNORVER; UKCA
<b>Ordering data</b>		
PUSH IN connection Type	TOP 24VDC 24VDC5A	TOP 24-230VUC 24VDC5A ED2
Order No.	<b>2618840000</b>	<b>2663150000</b>
Screw connection Type	TOS 24VDC 24VDC5A	TOS 24-230VUC 24VDC5A ED2
Order No.	<b>1990960000</b>	<b>2662990000</b>
<b>Note</b>		

1 CO contact, cl. 1, div. 2

AC / DC / UC coil

- Space-saving, only 6.4 mm wide
- AgNi contact
- Multi-voltage input: 24...230 V UC in one module
- Screw connection



B

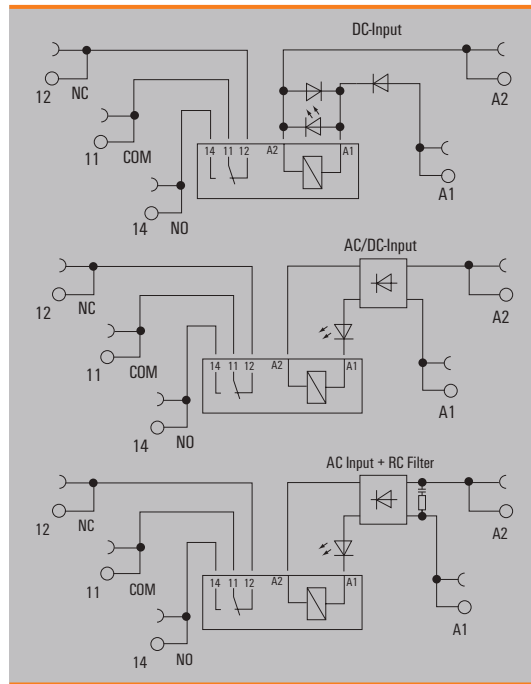

Technical data

Load side	
Rated switching voltage / Continuous current	250 V AC / 6 A
Max. switching voltage, AC	250 V
Inrush current	20 A / 20 ms
Min. switching power	1 mA @ 24 V, 10 mA @ 12 V, 100 mA @ 5 V
Contact type	1 CO contact (AgNi)
Mechanical service life	5 x 10 <sup>6</sup> switching cycles
Max. switching frequency at rated load	0.1 Hz
General data	
Ambient temperature (operational)	-40 °C...60 °C
Storage temperature	-40 °C...85 °C
Humidity	5-95% relative humidity, T <sub>0</sub> = 40°C, without condensation
Approvals	CE; cULusEX; UKCA
Insulation coordinates	
Rated voltage	300 V
Impulse withstand voltage	6 kV (1.2/50 µs)
Dielectric strength for control side - load side	4 kV <sub>eff</sub> / 1 Min.
Dielectric strength of neighbouring contacts	
Dielectric strength to mounting rail	4 kV <sub>eff</sub> / 1 Min.
Clearance and creepage distances for control side - load side	≥ 6 mm
Overvoltage category	III
Pollution degree	2
Dimensions	
Clamping range (nominal / min. / max.)	mm <sup>2</sup> 1.5 / 0.14 / 2.5
Depth x width x height	mm 87.8 / 6.4 / 89.6
Note	
Accessories and dimensional drawings: refer to the TERMSERIES Accessories page. Further approvals and technical data can be found at <a href="http://eshop.weidmueller.com">eshop.weidmueller.com</a>	

Applications

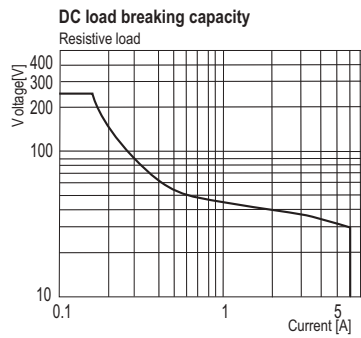
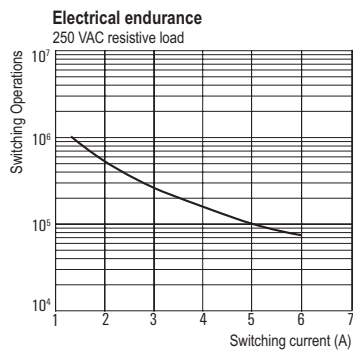

1 CO contact, cl. 1, div. 2  
AC / DC / UC coil

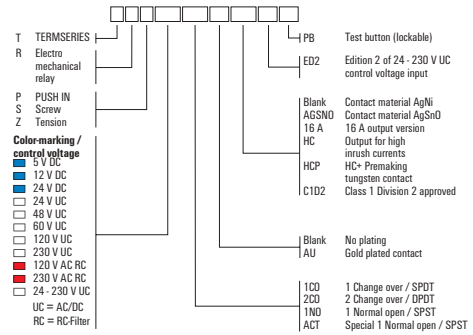

Ordering data

	12 V DC	24 V DC	24 V UC	120 V AC RC	230 V AC RC
<b>Control side</b>					
Rated control voltage	12 V DC ± 20 %	24 V DC ± 20 %	24 V UC ± 10 %	120 V AC ± 10 %	230 V AC ± 10 %
Rated current AC / DC	/ 18 mA	/ 11.5 mA	11.7 mA / 6.4 mA	7 mA /	8.5 mA /
Power rating	210 mW	280 mW	270 mVA / 154 mW	840 mVA	2 VA
Status indicator	Green LED	Green LED	Green LED	Green LED	Green LED
Protective circuit	Free-wheeling diode, Reverse polarity protection	Free-wheeling diode, Reverse polarity protection	Rectifier	Rectifier, RC element	Rectifier, RC element

Ordering data						
Screw connection	Type	TRS 12VDC 1CO C1D2	TRS 24VDC 1CO C1D2	TRS 24VUC 1CO C1D2	TRS 120VACRC 1CO C1D2	TRS 230VACRC 1CO C1D2
	Order No.	<b>1984560000</b>	<b>1984570000</b>	<b>1984580000</b>	<b>1984590000</b>	<b>1984600000</b>
	Type					
	Order No.					
Note						

Ordering data

	24...230 V UC
<b>Control side</b>	
Rated control voltage	24...230 V UC ± 10 %
Rated current AC / DC	27.1 mA AC @ 24 V AC, 4.8 mA AC @ 230 V AC / 25.6 mA DC @ 24 V DC, 2.5 mA DC @ 230 V DC
Power rating	610 mW @ 24 V DC, 650 mVA @ 24 V AC, 575 mW @ 230 V DC, 1.1 VA @ 230 V AC
Status indicator	Green LED
Protective circuit	Rectifier

Ordering data	
Screw connection	Type
	TRS 24-230VUC 1CO C1D2
	Order No.
	<b>1984610000</b>
	Type
	Order No.
Note	

1 CO contact, cl. 1, div. 2

With hard gold-plated contacts

AC / DC / UC coil

- Space-saving, only 6.4 mm wide
- AgNi contact with hard gold plating
- Multi-voltage input: 24...230 V UC in one module
- Screw connection

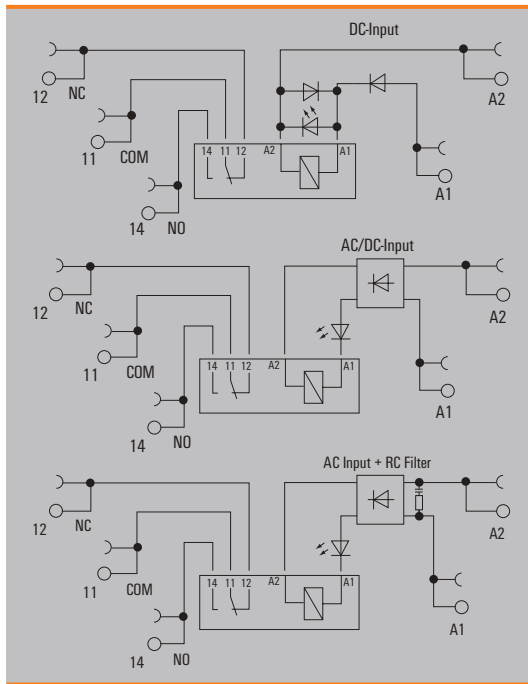

Technical data

Load side	
Rated switching voltage / Continuous current	250 V AC / 6 A
Max. switching voltage, AC	250 V
Inrush current	20 A / 20 ms
Min. switching power	1 mA @ 1 V
Contact type	1 CO contact (AgNi gold-plated)
Mechanical service life	5 x 10 <sup>6</sup> switching cycles
Max. switching frequency at rated load	0.1 Hz
General data	
Ambient temperature (operational)	-40 °C...60 °C
Storage temperature	-40 °C...85 °C
Humidity	5-95% relative humidity, T <sub>0</sub> = 40°C, without condensation
Approvals	CE; cULusEX; UKCA
Insulation coordinates	
Rated voltage	300 V
Impulse withstand voltage	6 kV (1.2/50 µs)
Dielectric strength for control side - load side	4 kV <sub>eff</sub> / 1 Min.
Dielectric strength of neighbouring contacts	
Dielectric strength to mounting rail	4 kV <sub>eff</sub> / 1 Min.
Clearance and creepage distances for control side - load side	≥ 6 mm
Overvoltage category	III
Pollution degree	2
Dimensions	
Clamping range (nominal / min. / max.)	mm <sup>2</sup> 1.5 / 0.14 / 2.5
Depth x width x height	mm 87.8 / 6.4 / 89.6
Note	
Accessories and dimensional drawings: refer to the TERMSERIES Accessories page. Further approvals and technical data can be found at <a href="http://eshop.weidmueller.com">eshop.weidmueller.com</a>	

Applications

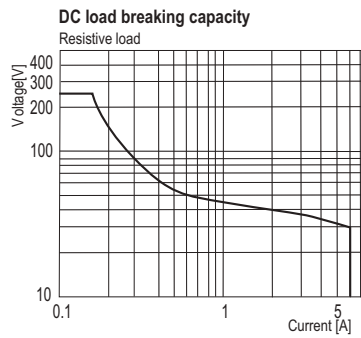
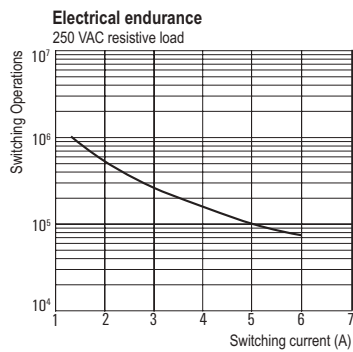

**1 CO contact, cl. 1, div. 2**  
**With hard gold-plated contacts**  
**AC / DC / UC coil**

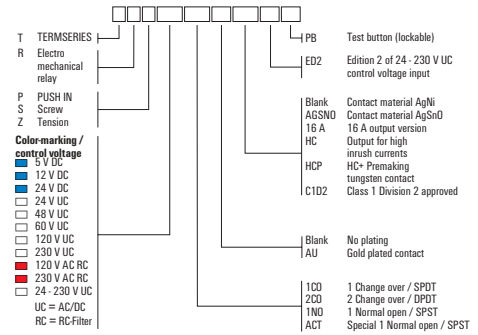

**Ordering data**

Control side	12 V DC	24 V DC	120 V AC RC	24-230 V UC
Rated control voltage	12 V DC ± 20 %	24 V DC ± 20 %	120 V AC ± 10 %	24...230 V UC ± 10 %
Rated current AC / DC	/ 18 mA	/ 11.5 mA	7 mA /	27.1 mA AC @ 24 V AC, 4.8 mA AC @ 230 V AC / 25.6 mA DC @ 24 V DC, 2.5 mA DC @ 230 V DC
Power rating	210 mW	280 mW	840 mVA	610 mW @ 24 V DC, 650 mVA @ 24 V AC, 575 mW @ 230 V DC, 1.1 VA @ 230 V AC
Status indicator	Green LED	Green LED	Green LED	Green LED
Protective circuit	Free-wheeling diode, Reverse polarity protection	Free-wheeling diode, Reverse polarity protection	Rectifier, RC element	Rectifier

Ordering data					
Screw connection	Type	TRS 12VDC 1COAU C1D2	TRS 24VDC 1COAU C1D2	TRS 120VACRC 1COAU C1D2	TRS 24-230VUC 1COAUC1D2
Order No.	Type	<b>1984620000</b>	<b>1984630000</b>	<b>1984640000</b>	<b>1984650000</b>
Order No.	Type				
Note					

# TERMSERIES accessories

## Increase productivity in control cabinet wiring

### B

Growing plant complexity and more individual production processes require higher flexibility and efficiency. Solid-state relays and relay modules from the TERMSERIES-compact and TERMSERIES can be added individually according to the application. In addition to many relay modules and solid-state relay variants, we offer you suitable supply terminals, partition plates, cross-connections and markers. This provides you with a flexible modular system for signal separation and amplification, enabling you to work better, faster and more reliably.

#### Adjustable cross-connections

Increase the flexibility of your cross-connections. The TERMSERIES CROSS-CONNECTION (TCC) enables individually adjustable cross-connections with up to 51 poles. The maximum number of pluggable poles has been increased to 32 poles. The strip material can be shortened to the required length very easily. The cross-connectors convince thanks to their easy handling and visibility as well as their universal connection possibilities. An additional bar prevents the spring from deforming during assembly.

#### Versatile partition plates

Partition plates can be used to group together signals visually, to electrically isolate modules and to insert markings for a better overview. This makes them a particularly versatile accessory. Partition plates increase the clearance and creepage distances between two modules, thus increasing the rated insulation voltage between two modules to up to 600 V. Double partition plates can be marked with WAD5 or WS10/5 markers and enable continuous cross-connections. Installation is made easier with the perforations to individually break out the cross-connection channels.

#### Comprehensive marking system

Marking in accordance with DIN EN 60204-1 is essential for the operation and maintenance of industrial plant. With our marking system we offer you a complete, perfectly coordinated product range of markers and printers. TERMSERIES products can be combined, for example, with the proven MultiCard format, which can be printed using various Weidmüller printers. On top of this are the innovative MultiMark terminal markers, which are particularly easy and precise to install thanks to their stretchable material. All markers guarantee excellent print results as well as long-lasting, resistant marking.

#### Space-saving feed-in terminals

For easy feed-in of neutral or negative potentials at the input of switched potentials at the output. Cross-connections enable space-saving connection of sensors and actuators without additional feed-through terminal blocks.

#### Precision-fit feed-through terminals

The precisely fitting terminals enable potentials to be brought from the control side to the load side and vice versa. Due to the compatibility with the TERMSERIES, there is a uniform test system with a standardised test tap.

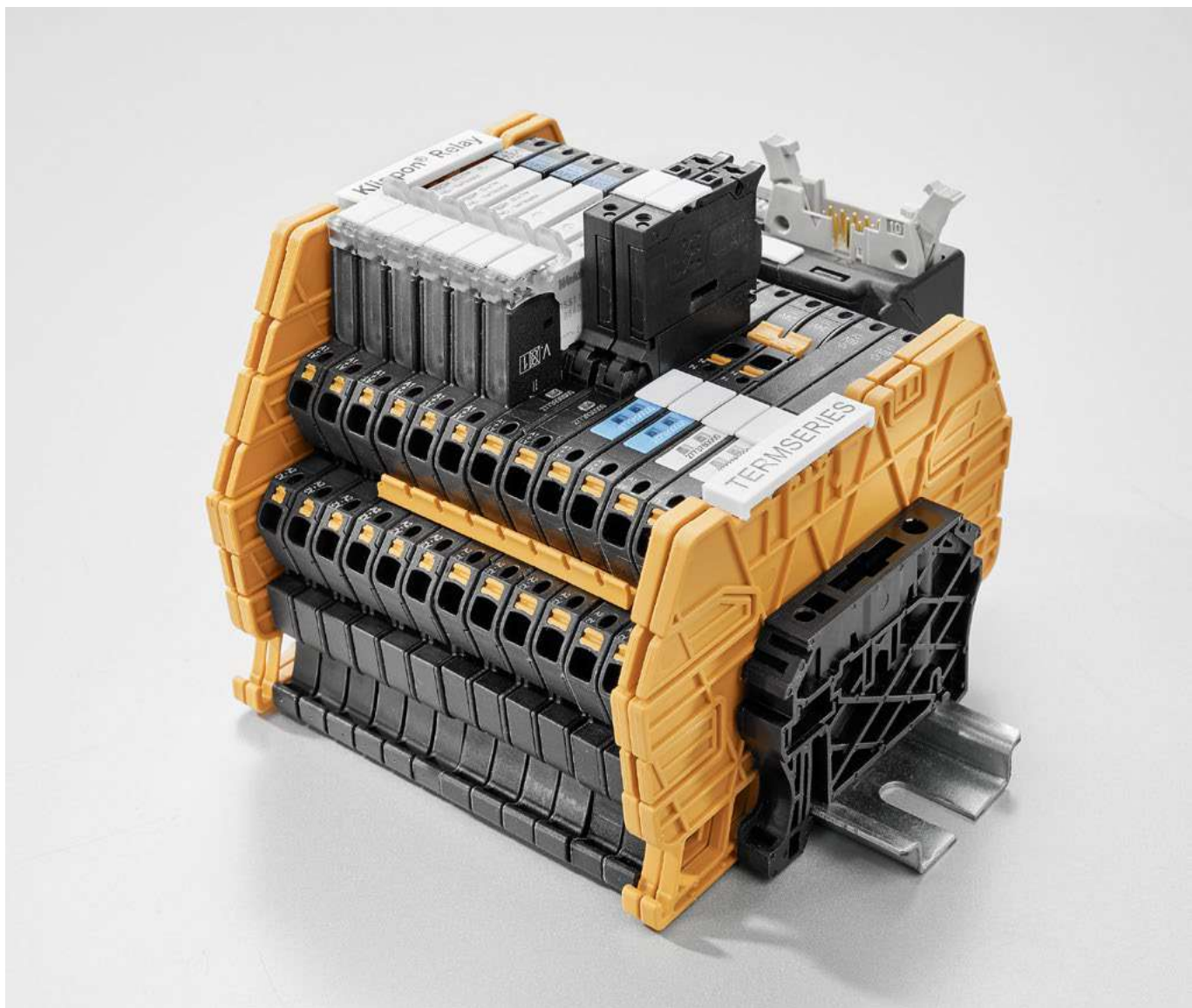

Visit our website for more information  
[www.weidmueller.com/term](http://www.weidmueller.com/term)  
[www.weidmueller.com/termcompact](http://www.weidmueller.com/termcompact)

**RCL relay module**



Similar to figure

Technical data	RSS113...	RSS112...	RS110...	RS111...
Contact type	1 CO contact (AgNi)	1 CO contact (AgNi 5uAu) <sup>1)</sup>	1 CO contact (AgSnO)	1 CO contact (AgSnO AU)
Max. switching voltage, AC	250 V	250 V	250 V	250 V
Max. switching voltage, DC	250 V	250 V	250 V	250 V
Rated switching voltage	6 A	6 A	6 A	6 A
	100 mA @ 5 V			
Min. switching power	10 mA @ 10 V	1 mA @ 1 V	100 mA @ 12 V	1 mA @ 1 V
	1 mA @ 24 V			
Mechanical service life	5 x 10 <sup>6</sup>	5 x 10 <sup>6</sup>	5 x 10 <sup>6</sup>	10 x 10 <sup>6</sup>
Note				

Type	Rated control voltage	Rated current DC	Order No.	Order No.	Order No.	Order No.
RSS...005	5 V DC	34 mA	4061580000	1174540000	1984100000	
RSS...012	12 V DC	14 mA	4061610000	1220670000	1984110000	
RSS...024	24 V DC	7 mA	4060120000	4061590000	1984090000	
RSS...060	60 V DC	3 mA	4061630000	4061600000	1984120000	
RSS...024F	24 V DC	7 mA	1454430000			
RSS...24T (with test button)	24 V DC	7 mA				2851620000
RSS...24Y	24 V DC	7 mA	2851640000		2851640000	

**RCL relay module**



Similar to figure

Technical data	RCL424...	RCL425...
Contact type	2 CO contact (AgNi)	2 CO contact (AgNi 5uAu) <sup>1)</sup>
Max. switching voltage, AC	250 V	250 V
Max. switching voltage, DC	250 V	250 V
Rated switching voltage	8 A	8 A
	100 mA @ 5 V	
Min. switching power	10 mA @ 12 V	1 mA @ 1 V
	1 mA @ 24 V	
Mechanical service life	30 x 10 <sup>6</sup>	30 x 10 <sup>6</sup>
Note		

Type	Rated control voltage	Rated current DC	Order No.	Order No.
RCL...005	5 V DC	80 mA	8693790000	1174490000
RCL...012	12 V DC	33 mA	4058560000	4074580000
RCL...024	24 V DC	16 mA	4058570000	4058580000
RCL...048	48 V DC	8 mA	4058750000	1201230000
RCL...060	60 V DC	6 mA	4058760000	1201260000
RCL...110	110 V DC	3 mA	4058590000	8828370000

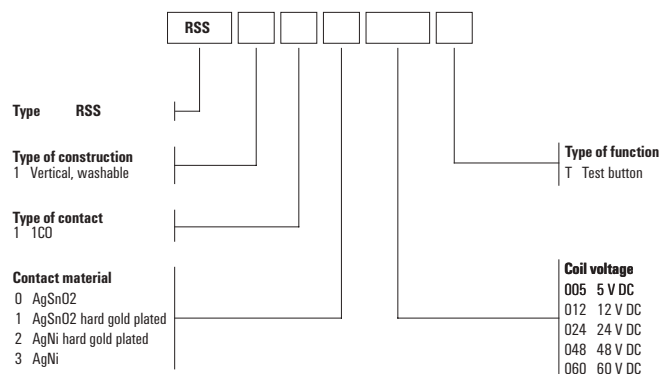

**Small solid-state relay**



Technical data	SSS...24 V 0,1 A DC	SSS...24 V 2 A DC	SSS...230 V 1 A AC
Contact type	1 NO contact (Bipolar transistor)	1 NO contact (MOS-FET)	Contact type 1 NO contact (Triac (zero-cross switch))
Rated switching voltage	0...48 V DC	0...24 V DC	24...240 V AC
Continuous current	100 mA DC	2 A	1 A
Min. switching current	500 µA	5 mA	20 mA
Voltage drop at max. load	≤ 1 V	≤ 120 mV	≤ 1 V
Leakage current	< 10 µA	< 10 µA	< 1.5 mA
Dielectric strength for control side - load side	2.5 kV <sub>eff</sub>	2.5 kV <sub>eff</sub>	2.5 kV <sub>eff</sub>
Operating temperature	-20 °C...60 °C	-20 °C...60 °C	-20 °C...60 °C
Storage temperature	-40 °C...70 °C	-40 °C...70 °C	-40 °C...70 °C

**Similar to figure**

Note			

Type	Rated control voltage	Nominal control current	Order No.	Order No.	Order No.
SSS 5 V...	5 V DC	4 mA DC	4064320000	-	-
SSS 24 V...	24 V DC	7 mA DC	4061180000	-	-
SSS 60 V...	60 V DC	3 mA DC	4061230000	-	-
SSS 5 V...	5 V DC	9 mA DC	-	4064310000	-
SSS 24 V...	24 V DC	7 mA DC	-	4061190000	-
SSS 60 V...	60 V DC	3 mA DC	-	4061200000	-
SSS 5 V...	5 V DC	15 mA DC	-	-	1132260000
SSS 24 V...	24 V DC	7 mA DC	-	-	4061210000
SSS 60 V...	60 V DC	3 mA DC	-	-	4061220000

**Solid-state relay**



Technical data	SSR.../0-35 V DC 3,5 A	SSR.../0-35VDC 5A	SSR.../12-275 V AC 1 A
Contact type	1 NO contact (MOS-FET)	1 NO contact (MOS-FET)	Contact type 1 NO contact (Triac (zero-cross switch))
Rated switching voltage	0...33 V DC	0...35 V DC	12...275 V AC
Continuous current	3.5 A	5 A	1 A
Min. switching current	10 mA	1 mA	50 mA
Voltage drop at max. load	≤ 0.3 V	≤ 0.3 V	≤ 1 V
Leakage current	< 10 µA	< 20 µA	< 1.5 mA
Dielectric strength for control side - load side	2.5 kV <sub>eff</sub>	2.5 kV <sub>eff</sub>	2.5 kV <sub>eff</sub>
Operating temperature	-20 °C...60 °C	-20 °C...80 °C	-20 °C...60 °C
Storage temperature	-40 °C...70 °C	-40 °C...100 °C	-40 °C...70 °C

**Similar to figure**

Note			

Type	Rated control voltage	Nominal control current	Order No.	Order No.	Order No.
SSR10...32 V DC/...	10...32 V DC	3...13 mA DC	1132310000	1421450000	1132290000

**Accessories**

The TERMSERIES relay sockets are fitted with internal circuitry in the input which adapts the control voltage to the coil voltage of the connected relay. It should be ensured that the voltages of the socket and the pluggable relay are compatible, since the control voltage and coil voltage are not always identical (see table below). For this reason, the coil voltage is printed on the relay sockets (refer to figure).

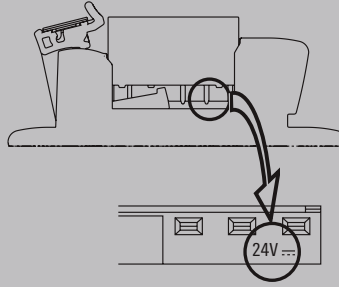

E.g.:  
A 24 V DC relay is plugged into the TERMSERIES 24 V DC socket (item no. 1123240000). The control voltage is transferred almost unchanged to the relay coil for this relay socket.  
Conversely, a 60V DC relay is plugged into the TERMSERIES 230 V AC relay socket (item no. 1123320000). The internal circuitry adapts the applied coil voltage to the control voltage.

**Empty socket 6,4 mm**



Rated control voltage	Plugable relay version	Qty.	Type / 1 CO PUSH IN	Order No.	Type / 1 CO Screw connection	Order No.
5 V DC	1	10	TRP 5VDC 1CO EMPTY	2614870000	TRS 5VDC 1CO EMPTY	1123220000
12 V DC	2	10	TRP 12VDC 1CO EMPTY	2618930000	TRS 12VDC 1CO EMPTY	1123230000
24 V DC	3	10	TRP 24VDC 1CO EMPTY	2618870000	TRS 24VDC 1CO EMPTY	1123240000
24 V UC	3	10	TRP 24VUC 1CO EMPTY	2618910000	TRS 24VUC 1CO EMPTY	1123250000
48 V UC	3	10	TRP 48VUC 1CO EMPTY	2618920000	TRS 48VUC 1CO EMPTY	1123270000
60 V UC	4	10	TRP 60VUC 1CO EMPTY	2618900000	TRS 60VUC 1CO EMPTY	1123280000
120 V UC	4	10	TRP 120VUC 1CO EMPTY	2618950000	TRS 120VUC 1CO EMPTY	1123290000
230 V UC	4	10	TRP 230VUC 1CO EMPTY	2618960000	TRS 230VUC 1CO EMPTY	1123300000
120 V AC	4	10	TRP 120VAC RC 1CO EMPTY	2618880000	TRS 120VAC RC 1CO EMPTY	1123310000
230 V AC	4	10	TRP 230VAC RC 1CO EMPTY	2618890000	TRS 230VAC RC 1CO EMPTY	1123320000
24...230 V AC / DC	3	10	TRP 24-230VUC 1CO EMPTY ED2	2663030000	TRS 24-230VUC 1CO EMPTY ED2	2662870000

Plugable relay version	Electromechanical relay	Solid-state relay
1	RSS...005	SSS 5V/...
2	RSS...012	-
3	RSS...024 / RSS...024F	SSS 24V/...
4	RSS...060	SSS 60V/...
5	RSS...24Y	
6	RSS...24T	

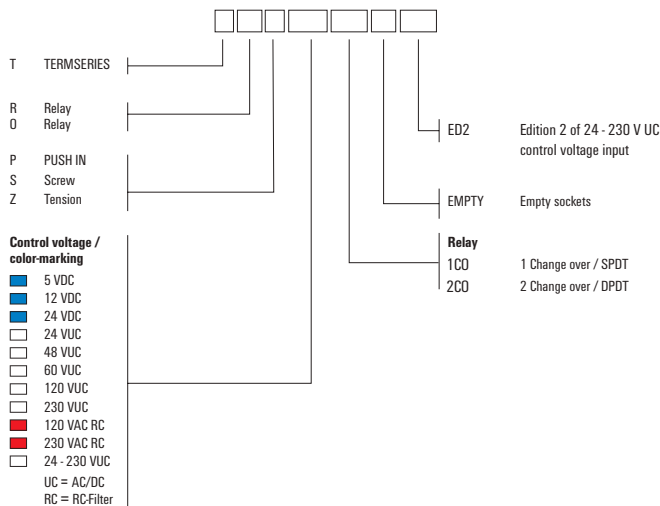

Empty socket 12,8 mm



Rated control voltage	Plugable relay version	Qty.	Type / 1 CO PUSH IN	Order No.	Type / 1 CO Screw connection	Order No.
24 V DC	1	10	TOP 24VDC EMPTY	2618740000	TOS 24VDC EMPTY	1127720000
24...230 V UC	1	10	TOP 24-230VUC EMPTY ED2	2663110000	TOS 24-230VUC EMPTY ED2	2662950000
Rated control voltage		Qty.	2 CO PUSH IN	Order No.	2 CO Screw connection	Order No.
5 V DC	2	10	TRP 5VDC 2CO EMPTY	2680850000	TRS 5VDC 2CO EMPTY	1123950000
12 V DC	3	10	TRP 12VDC 2CO EMPTY	2680960000	TRS 12VDC 2CO EMPTY	1123970000
24 V DC	4	10	TRP 24VDC 2CO EMPTY	2680970000	TRS 24VDC 2CO EMPTY	1123980000
24 V UC	4	10	TRP 24VUC 2CO EMPTY	2680980000	TRS 24VUC 2CO EMPTY	1123990000
48 V UC	5	10	TRP 48VUC 2CO EMPTY	2680990000	TRS 48VUC 2CO EMPTY	1124000000
60 V UC	6	10	TRP 60VUC 2CO EMPTY	2681000000	TRS 60VUC 2CO EMPTY	1124010000
120 V UC	7	10	TRP 120VUC 2CO EMPTY	2681010000	TRS 120VUC 2CO EMPTY	1124020000
230 V UC	7	10	TRP 230VUC 2CO EMPTY	2681020000	TRS 230VUC 2CO EMPTY	1124030000
120 V AC	7	10	TRP 120VAC RC 2CO EMPTY	2681030000	TRS 120VAC RC 2CO EMPTY	1124040000
230 V AC	7	10	TRP 230VAC RC 2CO EMPTY	2681190000	TRS 230VAC RC 2CO EMPTY	1124050000
24...230 V AC / DC	4	10	TRP 24-230VUC 2CO EMPTY ED2	2663060000	TRS 24-230VUC 2CO EMPTY ED2	2662900000

Plugable relay version	Electromechanical relay	Solid-state relay
1	RCL31024 ; RCLS3LD24W ; RCLS3TO24W	SSR 10-32VDC... ; SSR 24 VDC...
2	RCL424005 ; RCL425005	-
3	RCL424012 ; RCL425012	-
4	RCL424024 ; RCL425024	SSR 10-32VDC... ; SSR 24 VDC...
5	RCL424048 ; RCL425048	-
6	RCL424060 ; RCL425060	-
7	RCL424110 ; RCL425110	SSR 10-32VDC... ; SSR 24 VDC...

Connection data

Gauge to IEC 60947-1		Size	PUSH IN	A1 / B1	Screw connection	A1 / B1
1 conductor						
Solid H07V-U		mm <sup>2</sup>	0.14...1.5		0.14...2.5	
Finely stranded H07V-K		mm <sup>2</sup>	0.14...2.5		0.14...2.5	
... with ferrule without collar		mm <sup>2</sup>	0.14...1.5		0.25...2.5	
... with ferrule with collar		mm <sup>2</sup>	0.14...1.5		0.25...2.5	
American Wire Gauge AWG.../1		AWG	26...14		26...14	
American Wire Gauge AWG.../7		AWG	26...14		26...16	
American Wire Gauge AWG.../19		AWG	26...14		26...16	
2 conductor with same size						
Solid H07V-U		mm <sup>2</sup>			0.5...1.0	
Finely stranded H07V-K		mm <sup>2</sup>			0.5...1.0	
... with twin ferrule		mm <sup>2</sup>	0.5...1.0		0.5...1.0	
Tightening torque, max.		Nm			0.4	
Stripping length		mm	9		8	

**Pluggable cross connection**

Type	No. of poles / Pitch	Colour	Qty.	Order No.
TCC 6.4/2 OR	2 / 6.4 mm	orange	10	2556350000
TCC 6.4/10 OR	10 / 6.4 mm	orange	10	2556360000
TCC 6.4/51 OR	51 / 6.4 mm	orange	10	2556370000
TCC 12.8/26 OR	26 / 12.8 mm	orange	10	2556380000
TCC 6.4/2 BL	2 / 6.4 mm	blue	10	2556430000
TCC 6.4/10 BL	10 / 6.4 mm	blue	10	2556440000
TCC 6.4/51 BL	51 / 6.4 mm	blue	10	2556450000
TCC 12.8/26 BL	26 / 12.8 mm	blue	10	2556460000
TCC 6.4/2 RD	2 / 6.4 mm	red	10	2556390000
TCC 6.4/10 RD	10 / 6.4 mm	red	10	2556400000
TCC 6.4/51 RD	51 / 6.4 mm	red	10	2556410000
TCC 12.8/26 RD	26 / 12.8 mm	red	10	2556420000
TCC 6.4/2 BK	2 / 6.4 mm	black	10	2556470000
TCC 6.4/10 BK	10 / 6.4 mm	black	10	2556480000
TCC 6.4/51 BK	51 / 6.4 mm	black	10	2556490000
TCC 12.8/26 BK	26 / 12.8 mm	black	10	2556500000



**Supply module**

Type	Connection technology	Qty.	Order No.
TXS SUPPLY	Screw connection	10	1240780000
TXP SUPPLY	PUSH IN connection	10	2618940000
TXPL S	PUSH IN connection	1	2774100000

**Feed-through terminal**

Type	Connection technology	Qty.	Order No.
TXPL FT	PUSH IN connection	1	2774080000

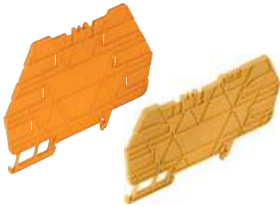
Other accessories

	Partition plate	Note	Qty.	Order No.
	TW TXS/TXZ R3.2	Partition plate 3.2 mm pitch	10	1240800000
	TXL PP	Partition plate 3.2 mm pitch	10	2774090000
	WS 10/6 MC NE WS	Markers for TERMSERIES variants with width of 6.4 mm or 12.8 mm	600	1818400000
	WS 10/12 MC NE WS	Markers for TERMSERIES variants with width of 12.8 mm	600	1905970000
	SDS 0.6X3.5X100	PUSH IN connection TERMSERIES-compact and Screw connection TERMSERIES	1	2749340000
	SDS 0.4X2.0X60	PUSH IN connection TERMSERIES	1	2749260000
	SDIS 0.6X3.5X100	PUSH IN connection TERMSERIES-compact and Screw connection TERMSERIES	1	2749810000
	SDIS 0.4X2.0X60	PUSH IN connection TERMSERIES	1	2749780000

Dimensions

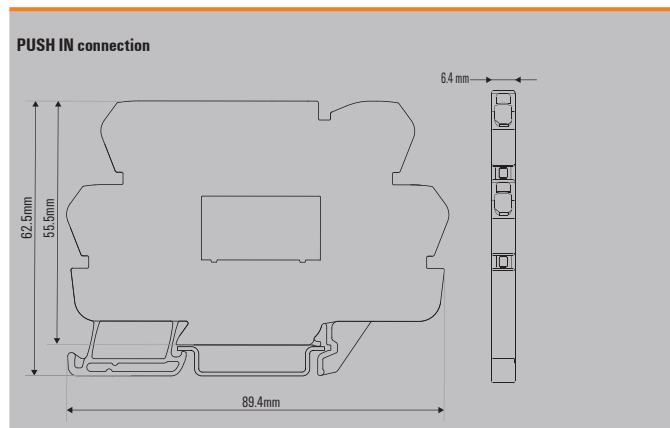
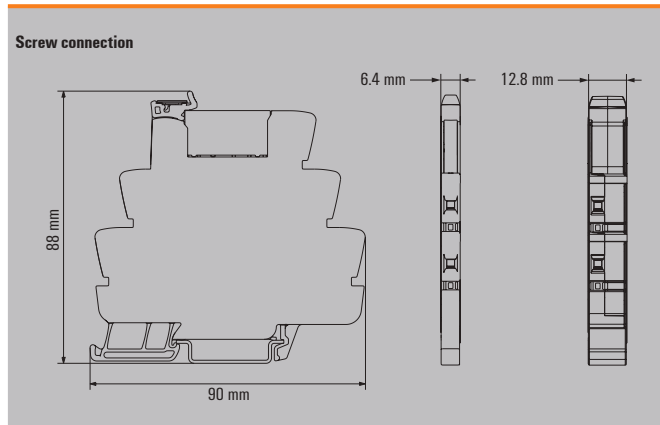
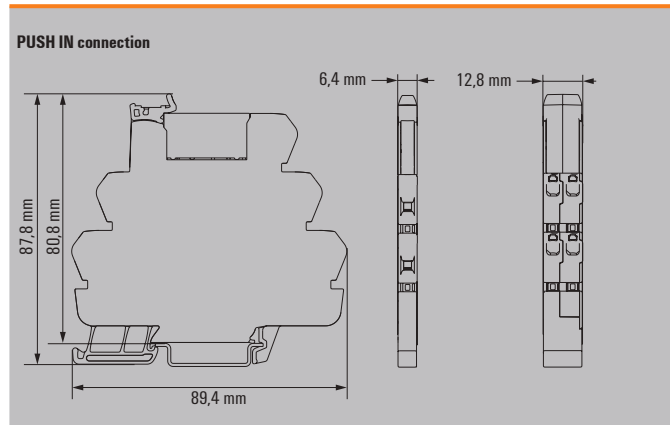

## TERMSERIES interface adapter

### Faster signal wiring with less space

## B

#### **Our adapter for TERMSERIES Relays reduces wiring times per plug-and-play**

To reduce wiring times, pre-assembled cables are used between the control system and the interface level and are simply connected to the TERMSERIES adapter. This enables throughput times in electrical cabinet building to be significantly reduced. The adapter has a universal fit and offers a genuine space advantage in interaction with the TERMSERIES-compact and TERMSERIES products with identical contours.



**Connection to a variety of controllers**

The standardized flat cable plug-in connections enables connection of all interface systems pre-assembled cable types.

**Fast supply and bridging of the auxiliary voltage**

Quick and safe supply of the auxiliary voltage as a result of the TOP connection with „PUSH IN“ technology. Simple bridging is also possible thanks to duplication of the connections.

**Reliable and unambiguous wiring**

Installation is unambiguous and safe thanks to practical marking of the connections, assignment of the contacts and the option of individual marking using MultiCard.

**Both types of logic with one device**

The potential switch for the lower level allows to use the adapter for plus and minus switching logic.

Visit our website for more information  
[www.weidmueller.com/term](http://www.weidmueller.com/term)

## TERMSERIES Interface adapters

### TERMSERIES Interface adapters

- Suitable for input and output logic
- Version for 6.4 mm TERMSERIES socket
- Supply connections (PUSH IN) in double version for supply voltage bridging
- User-friendly and clear marking
- 10-pole connecting plug according to DIN EN 60603-13

### TIA F10



### Potential change-over switch

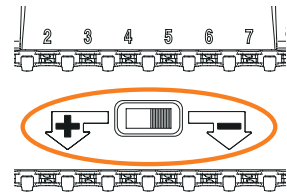

The potential change-over switch is located between contact rows of the TERMSERIES adaptor. It is used to switch the potential of the lower contact row to "+" or "-" potential of the supply voltage.

### Installation input

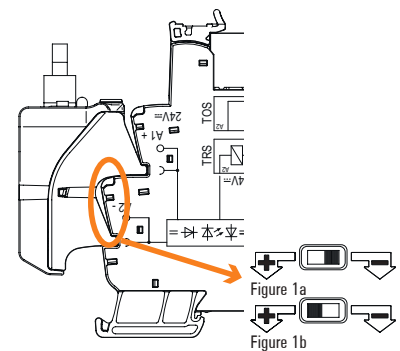

Figure 1a: **Positive-switching logic:** Potential change-over switch to "-", installation on **24 V DC input (A1/A2)**.  
 Figure 1b: **Negative-switching logic:** Potential change-over switch to "+", installation on **24 V UC input (A1/A2)**.

### Installation output

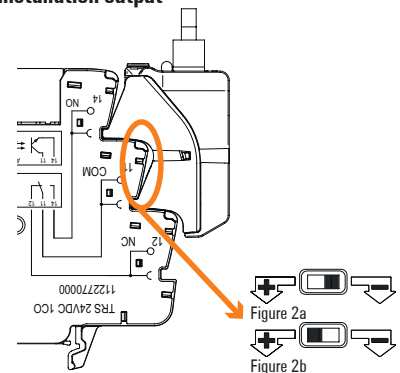
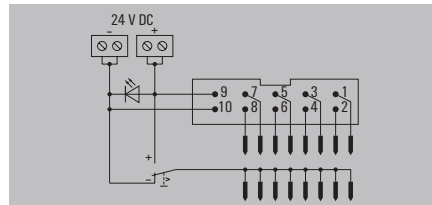

Figure 2a: **Positive-switching logic:** Potential change-over switch to "+", installation on output (11/14).  
 Figure 2b: **Negative-switching logic:** Potential change-over switch to "-", installation on output (11/14).



### Technical data

Supply	
Voltage supply	24 V DC ± 20 %
Status display	Green LED
Signals	
Rated voltage	24 V
Voltage, max.	30 V
Rated current (per signal path)	125 mA
Current (per signal path), max.	1 A
Total current of all signals, max.	1 A
Number of signal paths	8
Connection data (supply)	
Wire connection method	PUSH IN
Clamping range, rated connection, min.	0.13 mm <sup>2</sup>
Clamping range, rated connection, max.	1.5 mm <sup>2</sup>
Number of terminals	4 (+, +, -, -)
Connection data (signal)	
Plug type	10-pole plug according to DIN EN 60603-13, long locking lever
General data	
Ambient temperature (operational)	-40 °C...60 °C
Storage temperature	-40 °C...85 °C
Humidity	5...95% (indoor), T <sub>a</sub> = 40°C, without condensation
UL 94 flammability rating	V-0
Approvals	CE; cULus; DETNORVER; UKCA
Insulation coordinates	
Pollution degree	2
Overvoltage category	III
Impulse withstand voltage	1.5 kV
Rated voltage	32 V
Protection degree	IP20 in installed state
Dimensions	
Depth x width x height	62 / 51 / 43 mm
Note	

Type	Qty.	Order No.
TIA F10	1	1463520000

### Ordering data

Note	
Suitable for 6.4 mm wide TERMSERIES socket	

### Accessories

Note	
Interface cables can be found in catalogue 4.5 - PLC / DCS System Cabling & Migration Solutions	

**TERMSERIES Interface adapters**

- Suitable for input and output logic
- Version for 6.4 mm TERMSERIES socket
- User-friendly and clear marking
- 15-pole Sub-D plug-in connector according to DIN 41652 / IEC 60807

**TIA SUBD 15S**



**Potential change-over switch**

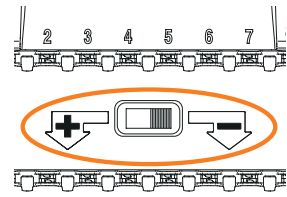

The potential change-over switch is located between contact rows of the TERMSERIES adaptor. It is used to switch the potential of the lower contact row to "+" or "-" potential of the supply voltage.

**Installation input**

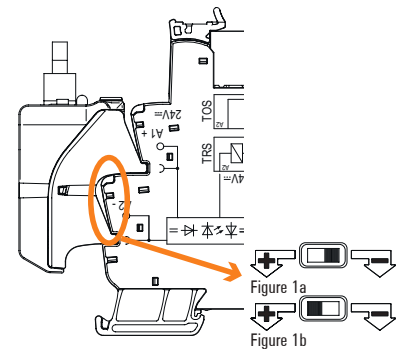

Figure 1a: **Positive-switching logic:** Potential change-over switch to "-", installation on **24 V DC input** (A1/A2).  
 Figure 1b: **Negative-switching logic:** Potential change-over switch to "+", installation on **24 V UC input** (A1/A2).

**Installation output**

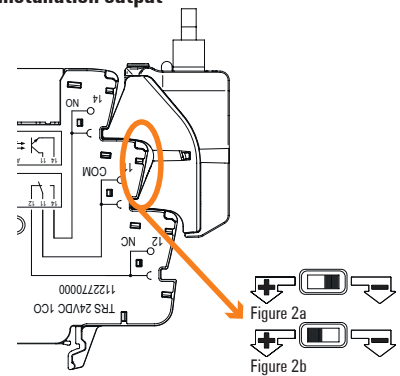
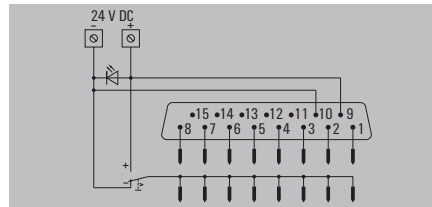

Figure 2a: **Positive-switching logic:** Potential change-over switch to "+", installation on output (11/14).  
 Figure 2b: **Negative-switching logic:** Potential change-over switch to "-", installation on output (11/14).



**Technical data**

<b>Supply</b>	
Voltage supply	24 V DC ± 20 %
Status display	Green LED
<b>Signals</b>	
Rated voltage	24 V
Voltage, max.	30 V
Rated current (per signal path)	125 mA
Current (per signal path), max.	1 A
Total current of all signals, max.	1 A
Number of signal paths	8
<b>Connection data (supply)</b>	
Wire connection method	PUSH IN
Clamping range, rated connection, min.	0.13 mm <sup>2</sup>
Clamping range, rated connection, max.	1.5 mm <sup>2</sup>
Number of terminals	2 (+,-)
<b>Connection data (signal)</b>	
Plug type	Sub-D, 15-pole, DIN 41652 / IEC 60807
<b>General data</b>	
Ambient temperature (operational)	-40 °C...60 °C
Storage temperature	-40 °C...85 °C
Humidity	5...95% (indoor), T <sub>a</sub> = 40°C, without condensation
UL 94 flammability rating	V-0
Approvals	CE; cULus; DETNORVER; UKCA
<b>Insulation coordinates</b>	
Pollution degree	2
Overvoltage category	III
Impulse withstand voltage	1.5 kV
Rated voltage	32 V
Protection degree	IP20 in installed state

<b>Dimensions</b>	
Depth x width x height	52 / 51 / 43 mm

<b>Note</b>	
-------------	--

**Ordering data**

Type	Qty.	Order No.
TIA SUBD 15S	1	1463530000

<b>Note</b>	Suitable for 6.4 mm wide TERMSERIES socket
-------------	--

**Accessories**

<b>Note</b>	Interface cables can be found in catalogue 4.5 - PLC / DCS System Cabling & Migration Solutions
-------------	---

**TERMSERIES Interface adapters**

**TERMSERIES Interface adapters**

- Suitable for input and output logic
- Version for 12.8 mm TERMSERIES socket
- Supply connections (PUSH IN) in double version for supply voltage bridging
- User-friendly and clear marking
- 10-pole connecting plug according to DIN EN 60603-13

**TIAL F10**

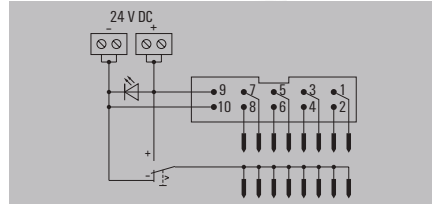

**Potential change-over switch**

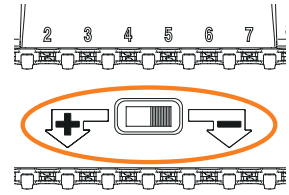

The potential change-over switch is located between contact rows of the TERMSERIES adaptor. It is used to switch the potential of the lower contact row to "+" or "-" potential of the supply voltage.

**Installation input**

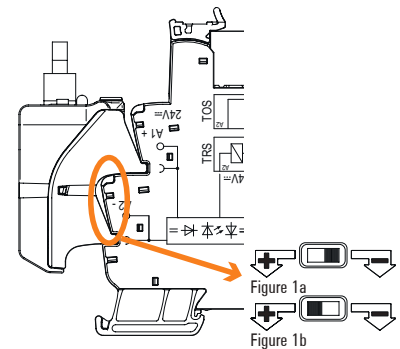

Figure 1a: **Positive-switching logic:** Potential change-over switch to "-", installation on **24 V DC input** (A1/A2).  
 Figure 1b: **Negative-switching logic:** Potential change-over switch to "+", installation on **24 V UC input** (A1/A2).

**Installation output**

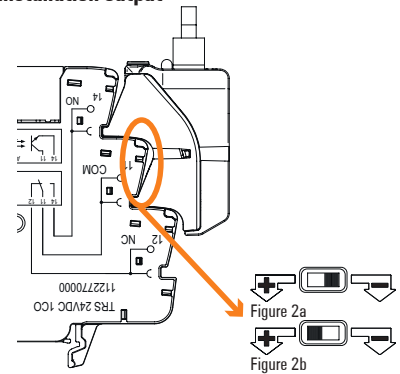

Figure 2a: **Positive-switching logic:** Potential change-over switch to "+", installation on output (11/14).  
 Figure 2b: **Negative-switching logic:** Potential change-over switch to "-", installation on output (11/14).

**Technical data**

<b>Supply</b>	
Voltage supply	24 V DC ± 20 %
Status display	Green LED
<b>Signals</b>	
Rated voltage	24 V
Voltage, max.	30 V
Rated current (per signal path)	125 mA
Current (per signal path), max.	1 A
Total current of all signals, max.	1 A
Number of signal paths	8
<b>Connection data (supply)</b>	
Wire connection method	PUSH IN
Clamping range, rated connection, min.	0.13 mm <sup>2</sup>
Clamping range, rated connection, max.	1.5 mm <sup>2</sup>
Number of terminals	4 (+, +, -, -)
<b>Connection data (signal)</b>	
Plug type	10-pole plug according to DIN EN 60603-13, long locking lever
<b>General data</b>	
Ambient temperature (operational)	-40 °C...60 °C
Storage temperature	-40 °C...85 °C
Humidity	5...95% (indoor), T <sub>a</sub> = 40°C, without condensation
UL 94 flammability rating	V-0
Approvals	CE; cULus; DETNORVER; UKCA
<b>Insulation coordinates</b>	
Pollution degree	2
Overvoltage category	III
Impulse withstand voltage	1.5 kV
Rated voltage	32 V
Protection degree	IP20 in installed state

<b>Dimensions</b>	
Depth x width x height	62 / 102 / 43 mm

<b>Note</b>	
-------------	--

**Ordering data**

Type	Qty.	Order No.
TIAL F10	1	1463540000

<b>Note</b>	Suitable for 12.8 mm wide TERMSERIES socket
-------------	---

**Accessories**

<b>Note</b>	Interface cables can be found in catalogue 4.5 - PLC / DCS System Cabling & Migration Solutions
-------------	---

**TERMSERIES Interface adapters**

- Suitable for input and output logic
- Version for 6.4 mm TERMSERIES socket
- Supply connections (PUSH IN) in double version for supply voltage bridging
- User-friendly and clear marking
- 20-pole connecting plug according to DIN EN 60603-13

**TIAL F20**



**Potential change-over switch**

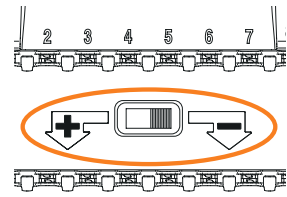

The potential change-over switch is located between contact rows of the TERMSERIES adaptor. It is used to switch the potential of the lower contact row to "+" or "-" potential of the supply voltage.

**Installation input**

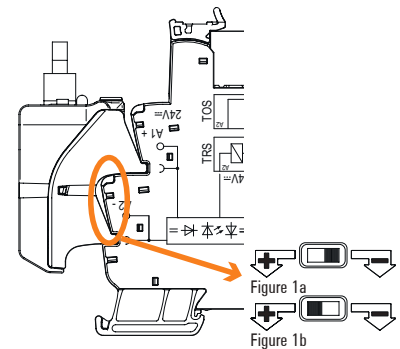

Figure 1a: **Positive-switching logic:** Potential change-over switch to "-", installation on **24 V DC input** (A1/A2).  
 Figure 1b: **Negative-switching logic:** Potential change-over switch to "+", installation on **24 V UC input** (A1/A2).

**Installation output**

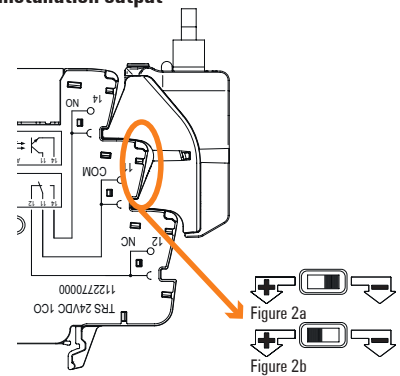
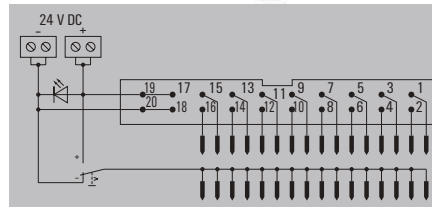

Figure 2a: **Positive-switching logic:** Potential change-over switch to "+", installation on **output** (11/14).  
 Figure 2b: **Negative-switching logic:** Potential change-over switch to "-", installation on **output** (11/14).



**Technical data**

<b>Supply</b>	
Voltage supply	24 V DC ± 20 %
Status display	Green LED
<b>Signals</b>	
Rated voltage	24 V
Voltage, max.	30 V
Rated current (per signal path)	60 mA
Current (per signal path), max.	1 A
Total current of all signals, max.	1 A
Number of signal paths	16
<b>Connection data (supply)</b>	
Wire connection method	PUSH IN
Clamping range, rated connection, min.	0.13 mm <sup>2</sup>
Clamping range, rated connection, max.	1.5 mm <sup>2</sup>
Number of terminals	4 (+, +, -, -)
<b>Connection data (signal)</b>	
Plug type	20-pole plug according to DIN EN 60603-13, long locking lever
<b>General data</b>	
Ambient temperature (operational)	-40 °C...60 °C
Storage temperature	-40 °C...85 °C
Humidity	5...95% (indoor), T <sub>v</sub> = 40°C, without condensation
UL 94 flammability rating	V-0
Approvals	CE; cULus; DETNORVER; UKCA
<b>Insulation coordinates</b>	
Pollution degree	2
Overvoltage category	III
Impulse withstand voltage	1.5 kV
Rated voltage	32 V
Protection degree	IP20 in installed state

<b>Dimensions</b>	
Depth x width x height	62 / 102 / 43 mm

<b>Note</b>	
-------------	--

**Ordering data**

Type	Qty.	Order No.
TIAL F20	1	1463550000

<b>Note</b>	Suitable for 6.4 mm wide TERMSERIES socket
-------------	--

**Accessories**

<b>Note</b>	Interface cables can be found in catalogue 4.5 - PLC / DCS System Cabling & Migration Solutions
-------------	---

## CUBESERIES – industrial relay modules from Europe

### PUSH IN and screw connections for quick installation

#### B

The CUBESERIES relay modules from Europe reliably switch small loads, decouple system parts and multiply signals in mechanical engineering as well as in process and energy technology. They impress with their durability and robust design.

They also offer relay modules with the contact versions 1 CO contact (16 A) and 2 CO contacts (8 A) from 15.6 mm width, as well as with 2 CO contacts (12 A) and 4 CO contacts (7 A) from a width of 27 mm. The relay sockets with PUSH IN and various cross-connections enable simple wiring, optimised for use in industrial automation.



#### Easy to use with screwdrivers

Both clamping points can be opened in parallel. The PUSH IN connection enables the use of industry-proven screwdrivers from 0.6 x 3.5 mm to 1.0 x 5.5 mm. This enables maintenance work to be carried out quickly and efficiently.



#### Easily accessible test points

The PUSH IN sockets have an additional test point, which makes maintenance much easier, since the pushers of the PUSH IN connections mean that there are no metal surfaces available for contacting measuring tips.



#### Variety of cross-connections

The PUSH IN sockets impress with their wide range of cross-connection options. The cross-connectors for the input side of the relay can simply be plugged in for the A1/A2 connections without covering the wire connection.

**Fast wiring with PUSH IN**

The wiring time is significantly reduced by the PUSH IN connection sockets. In addition, the pusher prevents incorrect operation of the connection.

**Lockable test buttons**

The test buttons (AC = orange, DC = blue) enable simple simulation of digital input and output signals. This allows machines and systems to be tested step by step during commissioning and maintenance.

**International approvals**

The internationally required cURus and CSA approvals enable use in systems for the American and Canadian markets.

**Extensive accessories**

Various accessories, such as the metal mounting brackets for applications subject to vibration, LED modules with red and green status LEDs and the protection modules with RC filters and varistors enable use in a wide range of applications.

**Relay modules from a width of 15.6 mm**

CUBESERIES offers relay modules from 15.6 mm width with the contact versions 1 CO contact (16 A) and 2 CO contacts (8 A), as well as with 2 CO contacts (12 A) and 4 CO contacts (7 A) from a width of 27 mm.

**Retaining clip with marker holder**

The plastic retaining clips have an ejector lever function and are fitted with a marker holder. This makes the retaining clips compatible with a wide range of marker systems on the market.

**CRI relay**

**1 CO contact, AC/DC coil**

- Versions with built-in LED or test button (AC-coil: orange, DC-coil: blue)
- Coloured housings at versions without test button (AC coil: orange, DC coil: blue)



**B**

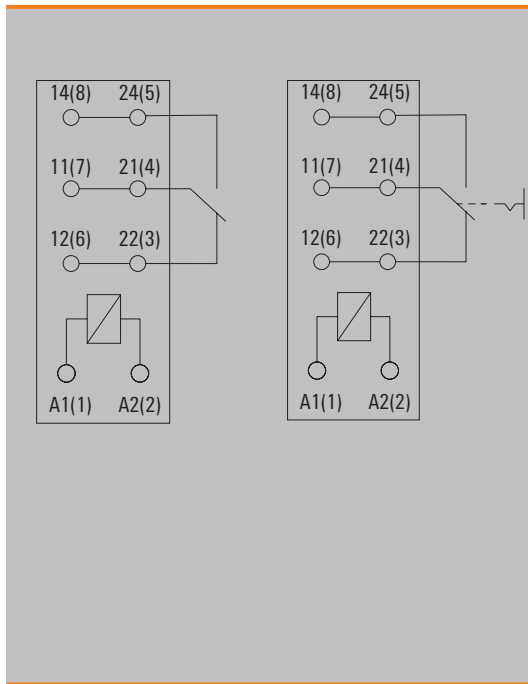

**Technical data**

Load side	
Rated switching voltage / Continuous current	250 V AC / 16 A
Max. switching voltage, AC	250 V
Min. switching power	10 mA @ 12 V, 100 mA @ 5 V
Mechanical service life	3 x 10 <sup>7</sup> switching cycles
Max. switching frequency at rated load	0.1 Hz
General data	
Ambient temperature (operational)	-20 °C...70 °C
Storage temperature	-40 °C...85 °C
Humidity	
Approvals	CSA, cURus
Insulation coordinates	
Rated voltage	250 V
Impulse withstand voltage	4 kV (1.2/50 µs)
Dielectric strength for control side - load side	5 kV <sub>eff</sub> / 1min
Dielectric strength of neighbouring contacts	
Dielectric strength to mounting rail	
Clearance and creepage distances for control side - load side	≥ 10 mm
Overtoltage category	III
Pollution degree	3
Dimensions	
Depth x width x height	see dimensioned drawing
Plug-in connection	
	see dimensioned drawing
Note	
	Further technical data can be found at <a href="http://eshop.weidmueller.com">eshop.weidmueller.com</a>

**Applications**

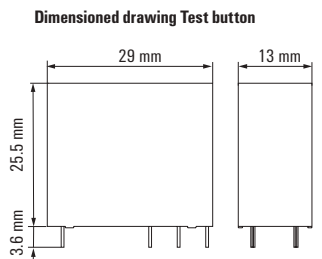
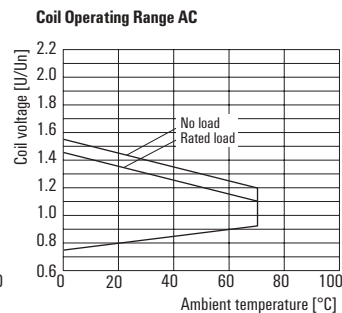
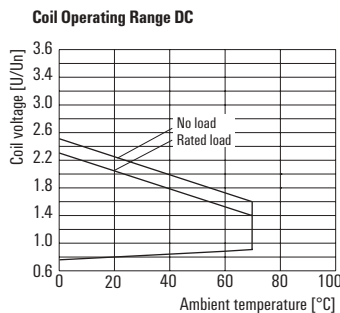
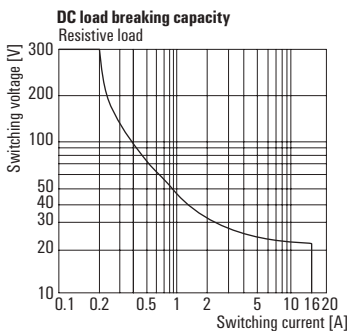
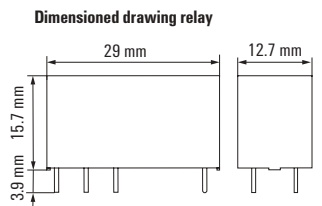
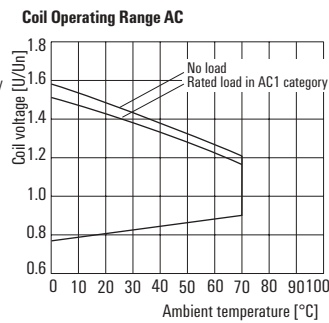
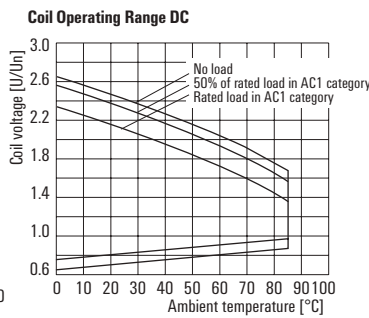
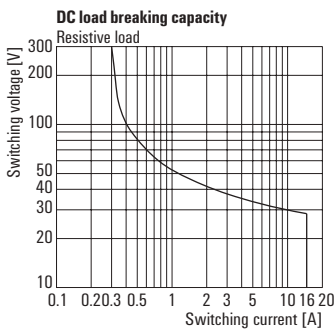

**CRI relay**  
**1 CO contact, AC/DC coil**

**Type code CUBESERIES relay versions**

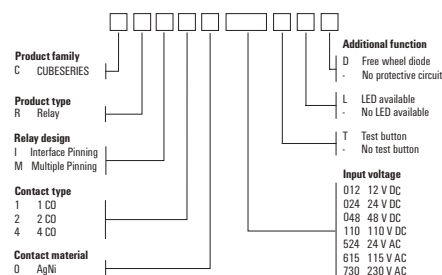

**Ordering data**

<b>Control side</b>		<b>12 V DC 1CO</b>	<b>24 V DC 1CO</b>	<b>48 V DC 1CO</b>	<b>110 V DC 1CO</b>
Rated control voltage		12 V DC	24 V DC	48 V DC	110 V DC
Rated current AC / DC		/ 33.3 mA	/ 16.7 mA	/ 8.3 mA	/ 3.5 mA
Power rating		400 mW	400 mW	400 mW	400 mW

<b>Ordering data</b>					
Standard	Type	CRI10012	CRI10024	CRI10048	CRI10110
	Order No.	<b>3052280000</b>	<b>3052290000</b>	<b>3052300000</b>	<b>3052310000</b>
with test button	Type	CRI10012T	CRI10024T	CRI10048T	CRI10110T
	Order No.	<b>3052350000</b>	<b>3052360000</b>	<b>3052370000</b>	<b>3052380000</b>
	Type				
	Order No.				
	Type				
	Order No.				

<b>Note</b>				

**Ordering data**

<b>Control side</b>		<b>24 V AC 1CO</b>	<b>115 V AC 1CO</b>	<b>230 V AC 1CO</b>
Rated control voltage		24 V AC	115 V AC	230 V AC
Rated current AC / DC		31.3 mA /	6.6 mA /	3.3 mA /
Power rating		0.75 VA	0.75 VA	0.75 VA

<b>Ordering data</b>				
Standard	Type	CRI10524	CRI10615	CRI10730
	Order No.	<b>3052320000</b>	<b>3052330000</b>	<b>3052340000</b>
with test button	Type	CRI10524T	CRI10615T	CRI10730T
	Order No.	<b>3052390000</b>	<b>3052400000</b>	<b>3052410000</b>
	Type			
	Order No.			
	Type			
	Order No.			

<b>Note</b>			

**CRI relay**

**2 CO contact, AC/DC coil**

- Versions with built-in LED or test button (AC-coil: orange, DC-coil: blue)
- Coloured housings at versions without test button (AC coil: orange, DC coil: blue)



**B**

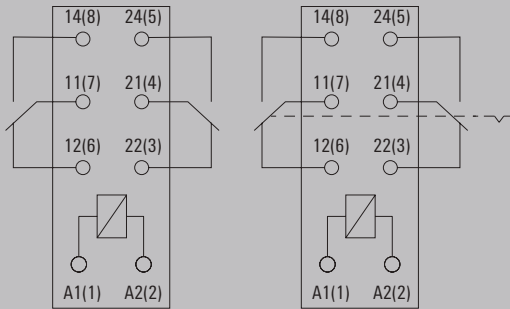

**Technical data**

Load side	
Rated switching voltage / Continuous current	250 V AC / 8 A
Max. switching voltage, AC	250 V
Min. switching power	10 mA @ 12 V, 100 mA @ 5 V
Mechanical service life	3 x 10 <sup>7</sup> switching cycles
Max. switching frequency at rated load	0.1 Hz
General data	
Ambient temperature (operational)	-20 °C...70 °C
Storage temperature	-40 °C...85 °C
Humidity	
Approvals	CSA, cURus
Insulation coordinates	
Rated voltage	250 V
Impulse withstand voltage	4 kV (1.2/50 µs)
Dielectric strength for control side - load side	5 kV <sub>eff</sub> / 1 min
Dielectric strength of neighbouring contacts	2.5 kV <sub>eff</sub> / 1 Min.
Dielectric strength to mounting rail	
Clearance and creepage distances for control side - load side	≥ 10 mm
Overvoltage category	III
Pollution degree	3
Dimensions	
Depth x width x height	see dimensioned drawing
Plug-in connection	
	see dimensioned drawing
Note	
	Further technical data can be found at <a href="http://eshop.weidmueller.com">eshop.weidmueller.com</a>

**Applications**

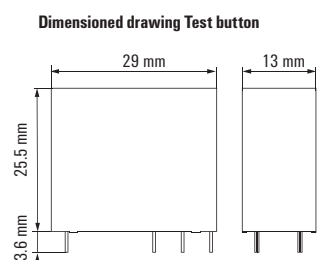
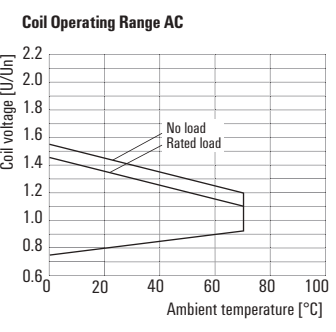
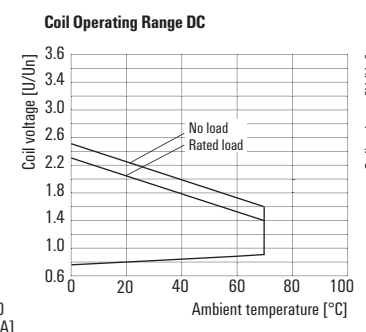
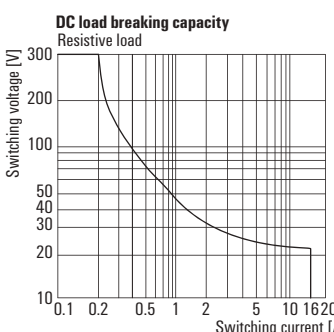
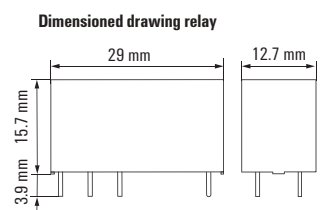
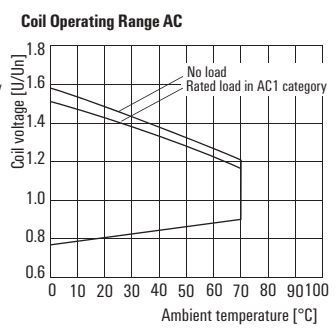
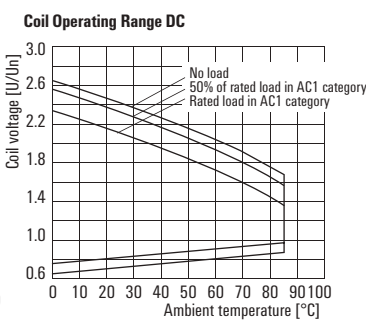
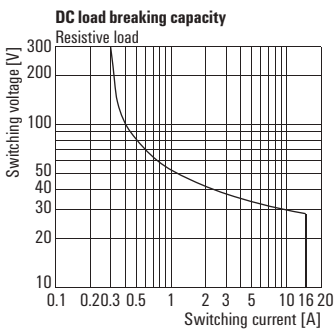

**CRI relay**  
**2 CO contact, AC/DC coil**

**Type code CUBESERIES relay versions**

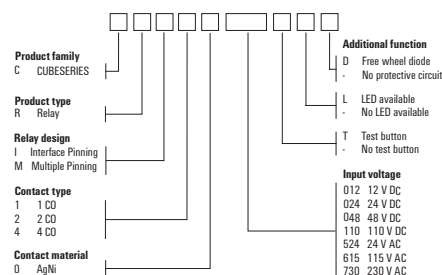

**Ordering data**

<b>Control side</b>		<b>12 V DC 2CO</b>	<b>24 V DC 2CO</b>	<b>48 V DC 2CO</b>	<b>110 V DC 2CO</b>
Rated control voltage		12 V DC	24 V DC	48 V DC	110 V DC
Rated current AC / DC		/ 33.3 mA	/ 16.7 mA	/ 8.3 mA	/ 3.5 mA
Power rating		400 mW	400 mW	400 mW	400 mW

<b>Ordering data</b>					
Standard	Type	CRI20012	CRI20024	CRI20048	CRI20110
	Order No.	<b>3052420000</b>	<b>3052430000</b>	<b>3052440000</b>	<b>3052450000</b>
with test button	Type	CRI20012T	CRI20024T	CRI20048T	CRI20110T
	Order No.	<b>3052500000</b>	<b>3052510000</b>	<b>3052520000</b>	<b>3052530000</b>
	Type				
	Order No.				
	Type				
	Order No.				

<b>Note</b>				

**Ordering data**

<b>Control side</b>		<b>24 V AC 2CO</b>	<b>115 V AC 2CO</b>	<b>230 V AC 2CO</b>
Rated control voltage		24 V AC	115 V AC	230 V AC
Rated current AC / DC		31.3 mA /	6.6 mA /	3.3 mA /
Power rating		0.75 VA	0.75 VA	0.75 VA

<b>Ordering data</b>				
Standard	Type	CRI20524	CRI20615	CRI20730
	Order No.	<b>3052460000</b>	<b>3052470000</b>	<b>3052490000</b>
with test button	Type	CRI20524T	CRI20615T	CRI20730T
	Order No.	<b>3052540000</b>	<b>3052550000</b>	<b>3052560000</b>
	Type			
	Order No.			
	Type			
	Order No.			

<b>Note</b>			

Universal range

B

Accessories for CRI relays

Socket with PUSH IN connection, 1 CO contact

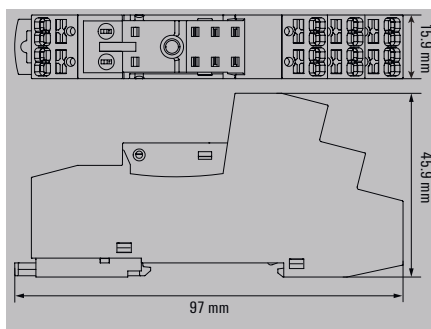

Socket with screw connection, 1 CO contact

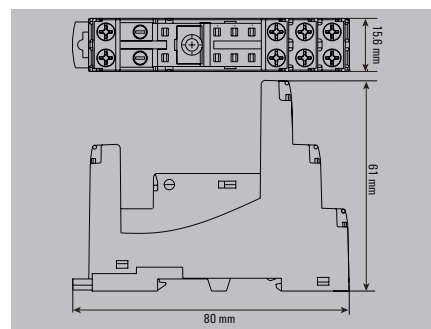

Technical data

<b>Load side</b>	
Rated switching voltage	250 V AC
Max. switching voltage, AC	300 V
Continuous current	8 A
<b>General data</b>	
Ambient temperature (operational)	-20 °C...70 °C
Storage temperature	
Approvals	CE; CSA; cURus
<b>Insulation coordinates</b>	
Protection degree	IP20
Clearance and creepage distances for control side - load side	
Dielectric strength for control side - load side	5 kV <sub>eff</sub> / 1min
Dielectric strength of neighbouring contacts	3 kV <sub>eff</sub> / 1 Min.
Impulse withstand voltage	4 kV
<b>Connection data</b>	
Clamping range (nominal / min. / max.)	1.5 / 0.5 / 1.5 mm <sup>2</sup>
Tightening torque	...
Stripping length, rated connection	10 mm
<b>Note</b>	

<b>Load side</b>		
Rated switching voltage	250 V AC	
Max. switching voltage, AC	300 V	
Continuous current	8 A	
<b>General data</b>		
Ambient temperature (operational)	-20 °C...70 °C	
Storage temperature		
Approvals	CE; CSA; cURus	
<b>Insulation coordinates</b>		
Protection degree	IP20	
Clearance and creepage distances for control side - load side		
Dielectric strength for control side - load side	5 kV <sub>eff</sub> / 1min	
Dielectric strength of neighbouring contacts	3 kV <sub>eff</sub> / 1 Min.	
Impulse withstand voltage	4 kV	
<b>Connection data</b>		
Clamping range (nominal / min. / max.)	1.5 / 0.5 / 1.5 mm <sup>2</sup>	
Tightening torque	...	
Stripping length, rated connection	10 mm	
<b>Note</b>		

<b>Load side</b>		
Rated switching voltage	250 V AC	
Max. switching voltage, AC	300 V	
Continuous current	8 A	
<b>General data</b>		
Ambient temperature (operational)	-40 °C...70 °C	
Storage temperature		
Approvals	CE; CSA; cURus	
<b>Insulation coordinates</b>		
Protection degree	IP20	
Clearance and creepage distances for control side - load side		
Dielectric strength for control side - load side	5 kV <sub>eff</sub> / 1min	
Dielectric strength of neighbouring contacts	3 kV <sub>eff</sub> / 1 Min.	
Impulse withstand voltage	6 kV	
<b>Connection data</b>		
Clamping range (nominal / min. / max.)	1.5 / / 1.5 mm <sup>2</sup>	
Tightening torque	...	
Stripping length, rated connection	10 mm	
<b>Note</b>		

Ordering data

Plug-in module on TS35 terminal rail
<b>Note</b>

Type	Qty.	Order No.
CSI P 2CO	20	3052570000

Type	Qty.	Order No.
CSI S 2CO	10	3052590000

Accessories

<b>Cross-connector</b>	
Screw connection, grey	
PUSH IN connection, red	
PUSH IN connection, blue	
PUSH IN connection, red	
PUSH IN connection, blue	
<b>Retaining clip</b>	
Plastic retaining bracket with marker holder	
Metal retaining clip for relay with test button	
Metal bracket for relay without test button	

Type	Qty.	Order No.
CXI CCS 8P GY	2	3052620000
CXI CCP 2P RD	20	3052650000
CXI CCP 2P BL	20	3052660000
CXI CCP 8P RD	10	3052690000
CXI CCP 8P BL	10	3052700000
CXI CLIP P	10	3052710000
CXI CLIP HM	10	3052640000
CXI CLIP LM	25	3052630000

Type	Qty.	Order No.
CXI CCS 8P GY	2	3052620000
CXI CCP 2P RD	20	3052650000
CXI CCP 2P BL	20	3052660000
CXI CCP 8P RD	10	3052690000
CXI CCP 8P BL	10	3052700000
CXI CLIP P	10	3052710000
CXI CLIP HM	10	3052640000
CXI CLIP LM	25	3052630000

<b>Note</b>
-------------

<b>Note</b>
-------------

<b>Note</b>
-------------



CRM relay

2 CO contact, AC/DC coil

- Coloured test buttons at versions with test buttons (AC coil: orange, DC coil: blue)
- Coloured blind plugs at versions without test buttons (AC coil: orange, DC coil: blue)
- Optional available with and without integrated green status LED
- Versions with integrated free-wheeling diode

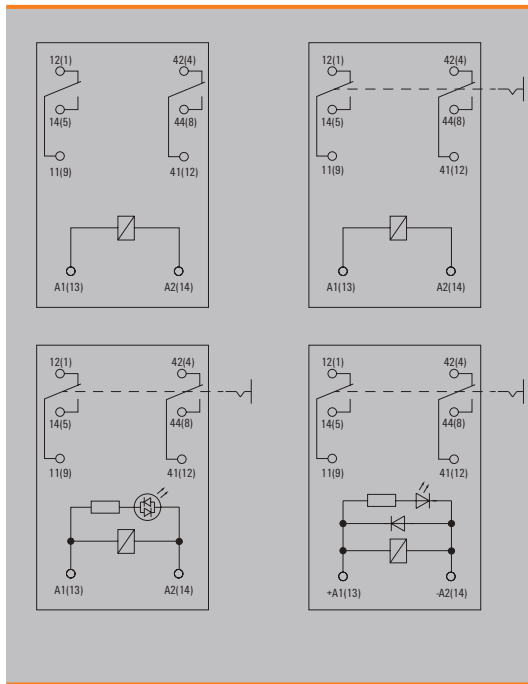

Technical data

Load side	
Rated switching voltage / Continuous current	250 V AC / 12 A
Max. switching voltage, AC	250 V
Inrush current	
Min. switching power	10 mA @ 12 V, 100 mA @ 5 V
Contact type	2 CO contact (AgNi)
Mechanical service life	2 x 10 <sup>7</sup> switching cycles
Max. switching frequency at rated load	0.1 Hz
General data	
Ambient temperature (operational)	-40 °C...70 °C
Storage temperature	-40 °C...85 °C
Humidity	25 °C / 95 % rel. humidity, no condensation
Approvals	CSA, cURus
Insulation coordinates	
Rated voltage	250 V
Impulse withstand voltage	4 kV (1.2/50 µs)
Dielectric strength for control side - load side	2.5 kV <sub>eff</sub> / 1 min
Dielectric strength of neighbouring contacts	2.5 kV <sub>eff</sub> / 1 min
Dielectric strength to mounting rail	
Clearance and creepage distances for control side - load side	
Overvoltage category	III
Pollution degree	3
Dimensions	
Depth x width x height	mm 35,5 / 21 / 27,4
Plug-in connection	
Depth x width x height	mm 35,5 / 21 / 27,4
Note	
Further technical data can be found at <a href="http://eshop.weidmueller.com">eshop.weidmueller.com</a>	

Applications

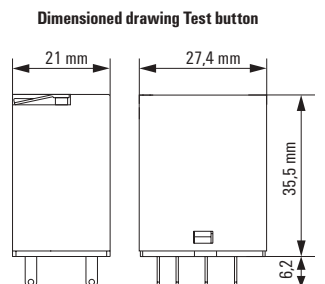
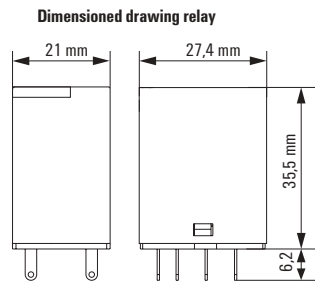
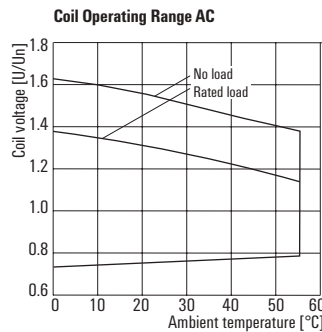
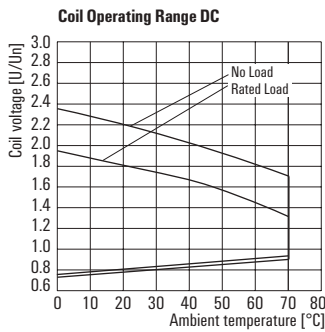
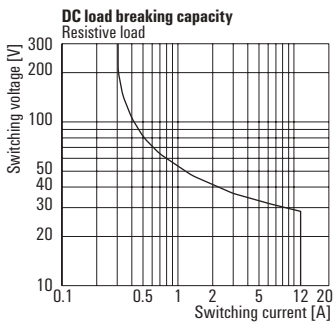

**CRM relay**  
2 CO contact, AC/DC coil

**Type code CUBESERIES relay versions**

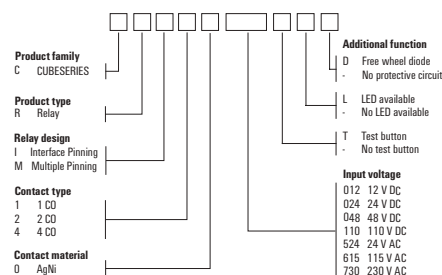

**Ordering data**

Control side	12 V DC 2CO	24 V DC 2CO	48 V DC 2CO	110 V DC 2CO
Rated control voltage	12 V DC	24 V DC	48 V DC	110 V DC
Rated current AC / DC	/ 75 mA	/ 37.8 mA	/ 18.5 mA	/ 8.3 mA
Power rating	0.9 W	0.9 W	0.9 W	0.9 W

**Ordering data**

Standard	Type	Order No.	CRM20012	CRM20024	CRM20048	CRM20110
Standard	Type	Order No.	CRM20012	CRM20024	CRM20048	CRM20110
with test button	Type	Order No.	<b>3052720000</b>	<b>3052730000</b>	<b>3052740000</b>	<b>3052750000</b>
with test button + LED	Type	Order No.	CRM20012T	CRM20024T	CRM20048T	CRM20110T
+ Free-wheel diode	Type	Order No.	<b>3052790000</b>	<b>3052800000</b>	<b>3052810000</b>	<b>3052820000</b>
	Type	Order No.	CRM20012TLD	CRM20024TLD	CRM20048TLD	CRM20110TLD
	Type	Order No.	<b>3052860000</b>	<b>3052870000</b>	<b>3052880000</b>	<b>3052890000</b>
	Type	Order No.				

Note				

**Ordering data**

Control side	24 V AC 2CO	115 V AC 2CO	230 V AC 2CO
Rated control voltage	24 V AC	115 V AC	230 V AC
Rated current AC / DC	69 mA /	14 mA /	7.1 mA /
Power rating	1.63 VA	1.63 VA	1.63 VA

**Ordering data**

Standard	Type	Order No.	CRM20524	CRM20615	CRM20730
Standard	Type	Order No.	CRM20524	CRM20615	CRM20730
with test button	Type	Order No.	<b>3052760000</b>	<b>3052770000</b>	<b>3052780000</b>
with test button + LED	Type	Order No.	CRM20524T	CRM20615T	CRM20730T
	Type	Order No.	<b>3052830000</b>	<b>3052840000</b>	<b>3052850000</b>
	Type	Order No.	CRM20524TL	CRM20615TL	CRM20730TL
	Type	Order No.	<b>3052900000</b>	<b>3052910000</b>	<b>3052920000</b>
	Type	Order No.			

Note				

CRM relay

4 CO contact, AC/DC coil

- Coloured test buttons at versions with test buttons (AC coil: orange, DC coil: blue)
- Coloured blind plugs at versions without test buttons (AC coil: orange, DC coil: blue)
- Optional available with and without integrated green status LED
- Versions with integrated free-wheeling diode

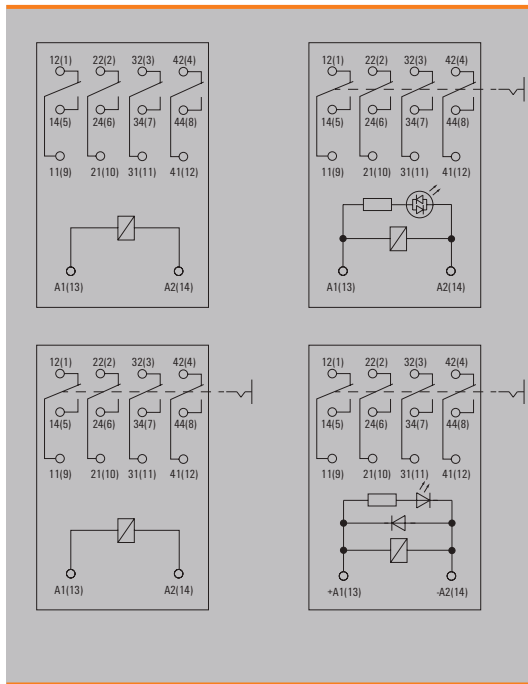

Technical data

Load side	
Rated switching voltage / Continuous current	250 V AC / 7 A
Max. switching voltage, AC	250 V
Inrush current	
Min. switching power	10 mA @ 12 V, 100 mA @ 5 V
Contact type	4 CO contact (AgNi)
Mechanical service life	2 x 10 <sup>7</sup> switching cycles
Max. switching frequency at rated load	0.1 Hz
General data	
Ambient temperature (operational)	-40 °C...70 °C
Storage temperature	-40 °C...85 °C
Humidity	25 °C / 95 % rel. humidity, no condensation
Approvals	CSA, cURus
Insulation coordinates	
Rated voltage	250 V
Impulse withstand voltage	4 kV (1.2/50 µs)
Dielectric strength for control side - load side	2.5 kV <sub>eff</sub> / 1 Min.
Dielectric strength of neighbouring contacts	2 kV <sub>eff</sub> / 1 min
Dielectric strength to mounting rail	
Clearance and creepage distances for control side - load side	
Overvoltage category	II
Pollution degree	2

Dimensions	Plug-in connection
Depth x width x height	mm 35,5 / 21 / 27,4

Note Further technical data can be found at [eshop.weidmueller.com](http://eshop.weidmueller.com)

Applications

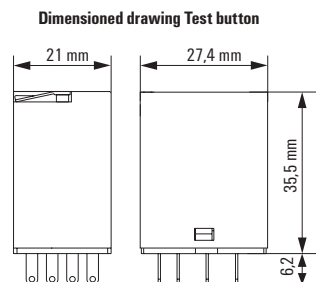
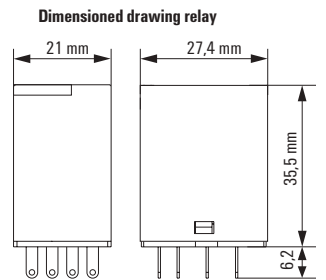
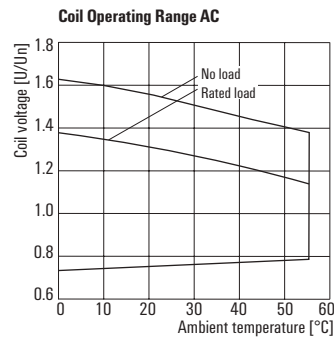
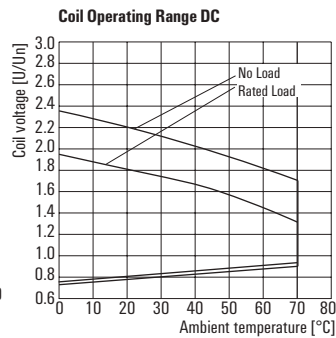
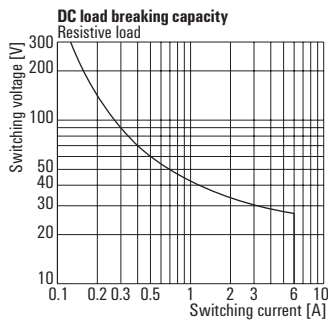

**CRM relay**  
**4 CO contact, AC/DC coil**

**Type code CUBESERIES relay versions**

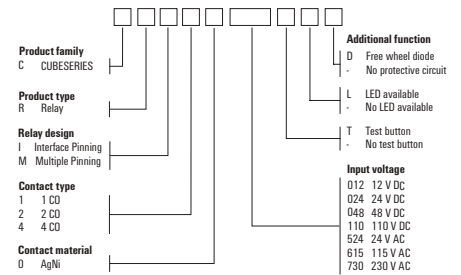

**Ordering data**

	12 V DC 4CO	24 V DC 4CO	48 V DC 4CO	110 V DC 4CO
<b>Control side</b>				
Rated control voltage	12 V DC	24 V DC	48 V DC	110 V DC
Rated current AC / DC	/ 75 mA	/ 37.8 mA	/ 18.5 mA	/ 8.3 mA
Power rating	0.9 W	0.9 W	0.9 W	0.9 W

**Ordering data**

	12 V DC 4CO	24 V DC 4CO	48 V DC 4CO	110 V DC 4CO
Standard	Type CRM40012	Type CRM40024	Type CRM40048	Type CRM40110
	Order No. <b>3052930000</b>	Order No. <b>3052940000</b>	Order No. <b>3052950000</b>	Order No. <b>3052960000</b>
with test button	Type CRM40012T	Type CRM40024T	Type CRM40048T	Type CRM40110T
	Order No. <b>3053000000</b>	Order No. <b>3053010000</b>	Order No. <b>3053020000</b>	Order No. <b>3053030000</b>
with test button + LED	Type CRM40012TLD	Type CRM40024TLD	Type CRM40048TLD	Type CRM40110TLD
+ Free-wheel diode	Order No. <b>3053070000</b>	Order No. <b>3053080000</b>	Order No. <b>3053090000</b>	Order No. <b>3053100000</b>
	Type	Type	Type	Type
	Order No.	Order No.	Order No.	Order No.

<b>Note</b>				
-------------	--	--	--	--

**Ordering data**

	24 V AC 4CO	115 V AC 4CO	230 V AC 4CO
<b>Control side</b>			
Rated control voltage	24 V AC	115 V AC	230 V AC
Rated current AC / DC	69 mA /	14 mA /	7.1 mA /
Power rating	1.63 VA	1.63 VA	1.63 VA

**Ordering data**

	24 V AC 4CO	115 V AC 4CO	230 V AC 4CO
Standard	Type CRM40524	Type CRM40615	Type CRM40730
	Order No. <b>3052970000</b>	Order No. <b>3052980000</b>	Order No. <b>3052990000</b>
with test button	Type CRM40524T	Type CRM40615T	Type CRM40730T
	Order No. <b>3053040000</b>	Order No. <b>3053050000</b>	Order No. <b>3053060000</b>
with test button + LED	Type CRM40524TL	Type CRM40615TL	Type CRM40730TL
	Order No. <b>3053110000</b>	Order No. <b>3053120000</b>	Order No. <b>3053130000</b>
	Type	Type	Type
	Order No.	Order No.	Order No.

<b>Note</b>			
-------------	--	--	--

Accessories for CRM relays

Socket with  
PUSH IN connection, 4 CO contact

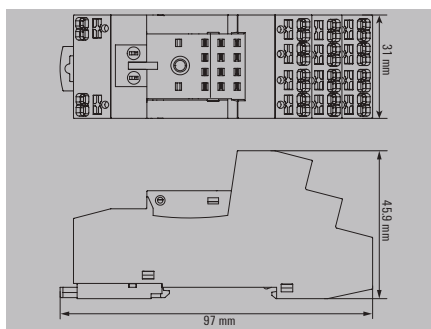

Socket with  
screw connection, 4 CO contact

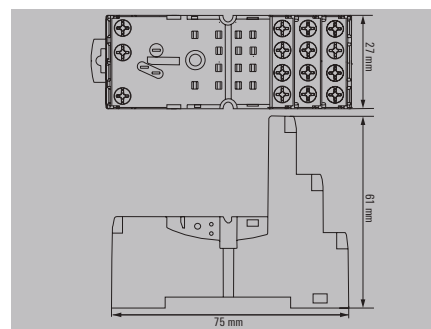

Technical data

Load side	
Rated switching voltage	250 V AC
Max. switching voltage, AC	300 V
Continuous current	8 A
General data	
Ambient temperature (operational)	-20 °C...70 °C
Approvals	CE, CSA, cURus
Insulation coordinates	
Protection degree	IP20
Dielectric strength for control side - load side	4 kV <sub>eff</sub> / 1 Min.
Dielectric strength of neighbouring contacts	3 kV <sub>eff</sub> / 1 Min.
Impulse withstand voltage	3 kV
Connection data	
Clamping range (nominal / min. / max.)	1.5 / 0.5 / 1.5 mm <sup>2</sup>
Stripping length, rated connection	8 mm
Note	

Technical data		
Rated switching voltage	250 V AC	
Max. switching voltage, AC	300 V	
Continuous current	8 A	
General data		
Ambient temperature (operational)	-20 °C...70 °C	
Approvals	CE, CSA, cURus	
Insulation coordinates		
Protection degree	IP20	
Dielectric strength for control side - load side	4 kV <sub>eff</sub> / 1 Min.	
Dielectric strength of neighbouring contacts	3 kV <sub>eff</sub> / 1 Min.	
Impulse withstand voltage	3 kV	
Connection data		
Clamping range (nominal / min. / max.)	1.5 / 0.5 / 1.5 mm <sup>2</sup>	
Stripping length, rated connection	8 mm	
Note		

Technical data		
Rated switching voltage	300 V	
Max. switching voltage, AC	300 V	
Continuous current	6 A	
General data		
Ambient temperature (operational)	-40 °C...70 °C	
Approvals	CE, CSA, cURus	
Insulation coordinates		
Protection degree	IP20	
Dielectric strength for control side - load side	4 kV <sub>eff</sub> / 1 Min.	
Dielectric strength of neighbouring contacts	3 kV <sub>eff</sub> / 1 Min.	
Impulse withstand voltage	3 kV	
Connection data		
Clamping range (nominal / min. / max.)	1.5 / / 1.5 mm <sup>2</sup>	
Stripping length, rated connection		
Note		

Ordering data

Plug-in module on TS35 terminal rail	
Note	

Type	Qty.	Order No.
CSM P 4CO	10	3053140000
Note		

Type	Qty.	Order No.
CSM S 4CO	10	3053160000
Note		

Accessories

Cross-connector	
Screw connection, grey	
PUSH IN connection, red	
PUSH IN connection, blue	
PUSH IN connection, red	
Retaining clip	
Plastic retaining bracket with marker holder	
Metal retaining clip	
2 pole jumper	
Free-wheeling diode	
Status LED + Free-wheeling diode	
Status LED	
RC element	
Varistor	
Note	

Type	Qty.	Order No.
CXM CCS 6P GY	2	3053180000
CXM CCP 2P RD	20	3053220000
CXM CCP 2P BL	20	3053230000
CXM CCP 8P RD	10	3053200000
CXM CLIP P	10	3053240000
CXM CLIP M	25	3053190000
CXX JMP 2P RD	30	3053250000
CXX JMP 2P BL	30	3053260000
CXX D 21N	20	3053270000
CXX LD 41R	20	3053290000
CXX LD 41G	20	3053310000
CXX LD 42R	20	3053320000
CXX LD 42G	20	3053340000
CXX L 61R	20	3053410000
CXX L 61G	20	3053420000
CXX RC 51	20	3053370000
CXX RC 52	20	3053390000
CXX RC 53	20	3053400000
CXX V 71	20	3053470000
CXX V 72	20	3053480000
CXX V 73	20	3053490000
Note		

Type	Qty.	Order No.
CXM CCS 6P GY	2	3053180000
CXM CCP 2P RD	20	3053220000
CXM CCP 2P BL	20	3053230000
CXM CCP 8P RD	10	3053200000
CXM CLIP P	10	3053240000
CXM CLIP M	25	3053190000
CXX JMP 2P RD	30	3053250000
CXX JMP 2P BL	30	3053260000
CXX D 21N	20	3053270000
CXX LD 41R	20	3053290000
CXX LD 41G	20	3053310000
CXX LD 42R	20	3053320000
CXX LD 42G	20	3053340000
CXX L 61R	20	3053410000
CXX L 62G	20	3053440000
CXX RC 51	20	3053370000
CXX RC 52	20	3053390000
CXX RC 53	20	3053400000
CXX V 71	20	3053470000
CXX V 72	20	3053480000
CXX V 73	20	3053490000
Note		

You can find further accessories at [eshop.weidmueller.com](http://eshop.weidmueller.com)

You can find further accessories at [eshop.weidmueller.com](http://eshop.weidmueller.com)



## D-SERIES

### Universal industrial relays with high efficiency

#### B

D-SERIES relays have been developed for universal use in industrial automation applications where high efficiency is required. They have many innovative functions and are available in a particularly large number of variants and in a wide range of designs for the most diverse applications. Thanks to various contact materials (AgNi and AgSnO etc.), D-SERIES products are suitable for low, medium and high loads. Variants with coil voltages from 5 V DC to 380 V AC enable use with every conceivable control voltage.

With relays from the D-SERIES, you can separate input and output signals reliably and benefit from many well-considered details. For example, conventional relays can simply be plugged in and fixed with a retaining clip. The clever contact series connection and a built-in blowout magnet reduce contact erosion for loads up to 220 V DC/10 A, thus extending the service life. The optional status LED plus test button ensures convenient service operations. D-SERIES relays are available in DRI and DRM versions with either sockets for PUSH IN technology or screw connection and can be supplemented with a wide range of accessories. These include markers and pluggable protective circuits with LEDs or free-wheeling diodes.

**Wide range of variants**

Thanks to the different series and designs, D-SERIES products are suitable for a wide range of industrial applications. With the DRI, DRM and DRR series in the universal range as well as the DRL, DRW and DRH series in the application range, a suitable solution is available for almost all applications.

**Solutions for special applications**

Relay modules for switching high DC loads up to 220 V DC complete the range and make the D-SERIES an all-rounder.

**Convenient relay KITS**

Our fully assembled and functionally tested relay KITS save time during installation and simplify logistics. They can each be ordered under a single item number and they reduce the number of storage locations.

**Long-lasting quality**

D-SERIES relays are extremely robust. They can be ordered with a wide range of suitable contact types for various industrial applications, which significantly extends the service life.

For further information,  
visit our website  
[www.weidmuller.com/dseries](http://www.weidmuller.com/dseries)

**D-SERIES – relay modules**

**DRI KIT with PUSH IN connection**

**1 CO contact, AC/DC coil**

- Mounted kit consisting relay, socket and retaining clip
- 100 % function tested
- 100 % check of the dielectric strenght between input - output
- Optional: test button with coloured control voltage marking (AC coil: red / DC coil: blue)
- Bright status LED (AC coil: red / DC coil: green)



**Circuit diagram**

**DC coil LED+diode**

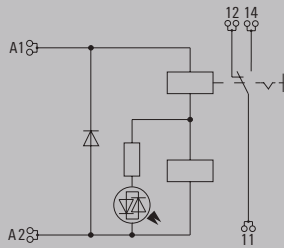

**AC coil LED:**

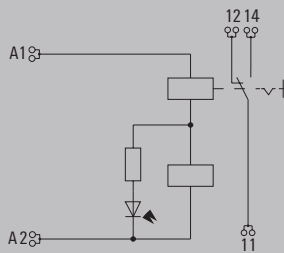

**Technical data**

Load side	
Rated switching voltage / Continuous current	250 V AC / 10 A
Max. switching voltage, AC	250 V
Min. switching power	10 mA @ 24 V, 10 mA @ 12 V, 100 mA @ 5 V
Contact type	1 CO contact (AgSnO)
Mechanical service life	10 x 10 <sup>6</sup> switching cycles
Max. switching frequency at rated load	0.1 Hz
General data	
Ambient temperature (operational)	-40 °C...55 °C
Storage temperature	-40 °C...85 °C
Humidity	35...85 % rel. humidity, no condensation
Approvals	CE, UKCA
Insulation coordinates	
Rated voltage	300 V
Impulse withstand voltage	5 kV (1.2/50 µs)
Dielectric strength for control side - load side	5 kV <sub>eff</sub> / 1min
Dielectric strength of neighbouring contacts	
Dielectric strength to mounting rail	
Clearance and creepage distances for control side - load side	≥ 3 mm
Overvoltage category	III
Pollution degree	2
Dimensions	
Clamping range (nominal / min. / max.)	mm <sup>2</sup> 1.5 / 0.14 / 1.5
Depth x width x height	see dimensioned drawing
Note	
Further technical data can be found at <a href="http://eshop.weidmueller.com">eshop.weidmueller.com</a>	

**Applications**

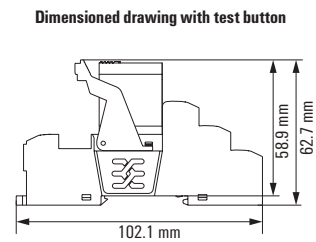
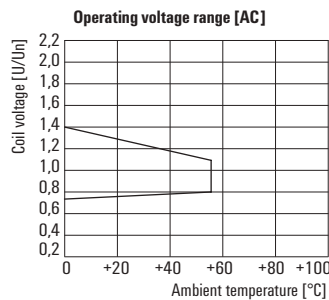
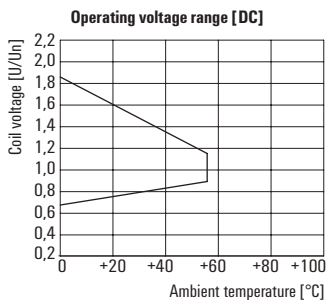
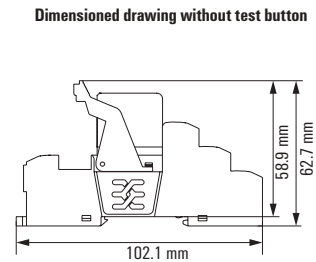
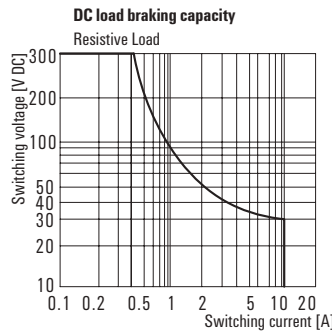
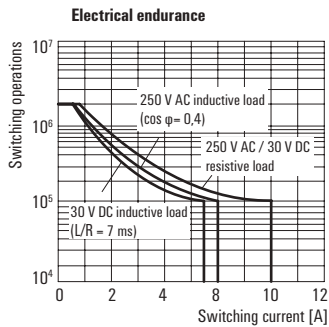

**DRI KIT with PUSH IN connection**  
**1 CO contact, AC/DC coil**

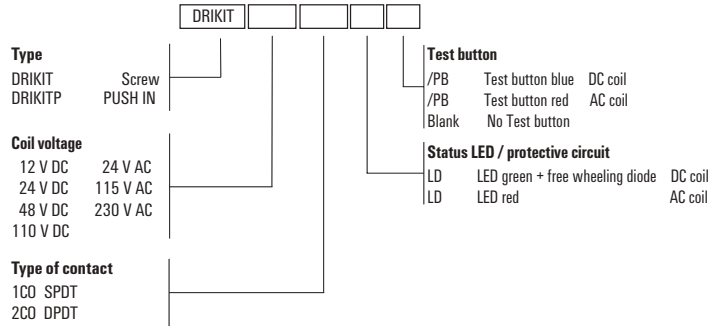

**Ordering data**

Control side	24 V DC 1CO	24 V AC 1CO	115 V AC 1CO	230 V AC 1CO
Rated control voltage	24 V DC	24 V AC	115 V AC	230 V AC
Rated current AC / DC	/ 21,8 mA	50 mA /	9,3 mA /	4,9 mA /
Power rating	530 mW	1,2 VA	1,1 VA	1,1 VA
Status indicator	Green LED	red LED	red LED	red LED
Protective circuit	Free-wheeling diode			

Ordering data		24 V DC 1CO	24 V AC 1CO	115 V AC 1CO	230 V AC 1CO
with test button	Type	DRIKITP 24VDC 1CO LD/PB	DRIKITP 24VAC 1CO LD/PB	DRIKITP115VAC 1CO LD/PB	DRIKITP230VAC 1CO LD/PB
	Order No.	<b>2576210000</b>	<b>2576250000</b>	<b>2576180000</b>	<b>2576160000</b>
without test button	Type	DRIKITP 24VDC 1CO LD	DRIKITP 24VAC 1CO LD	DRIKITP 115VAC 1CO LD	DRIKITP 230VAC 1CO LD
	Order No.	<b>2576220000</b>	<b>2576260000</b>	<b>2575980000</b>	<b>2576280000</b>
	Type				
	Order No.				
	Type				
	Order No.				

Note	24 V DC 1CO	24 V AC 1CO	115 V AC 1CO	230 V AC 1CO

**D-SERIES – relay modules**

**DRI KIT with screw connection**

**1 CO contact, AC/DC coil**

- Mounted kit consisting relay, socket and retaining clip
- 100 % function tested
- 100 % check of the dielectric strenght between input - output
- Optional: test button with coloured control voltage marking (AC coil: red / DC coil: blue)
- Bright status LED (AC coil: red / DC coil: green)



**Circuit diagram**

**DC coil LED+diode**

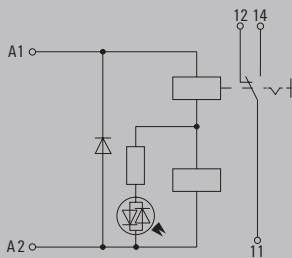

**AC coil LED:**

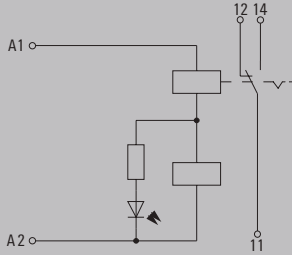

**Technical data**

Load side	
Rated switching voltage / Continuous current	250 V AC / 10 A
Max. switching voltage, AC	250 V
Min. switching power	10 mA @ 24 V, 10 mA @ 12 V, 100 mA @ 5 V
Contact type	1 CO contact (AgSnO)
Mechanical service life	10 x 10 <sup>8</sup> switching cycles
Max. switching frequency at rated load	0.1 Hz
General data	
Ambient temperature (operational)	-40 °C...55 °C
Storage temperature	-40 °C...85 °C
Humidity	35...85 % rel. humidity, no condensation
Approvals	CE, UKCA
Insulation coordinates	
Rated voltage	250 V
Impulse withstand voltage	4.8 kV (1.2/50 µs)
Dielectric strength for control side - load side	4 kV <sub>eff</sub> / 1 Min.
Dielectric strength of neighbouring contacts	
Dielectric strength to mounting rail	
Clearance and creepage distances for control side - load side	≥ 3 mm
Overvoltage category	III
Pollution degree	2
Dimensions	
Clamping range (nominal / min. / max.)	mm <sup>2</sup> 1.5 / 0.25 / 4
Depth x width x height	see dimensioned drawing
Note	
Further technical data can be found at <a href="http://eshop.weidmueller.com">eshop.weidmueller.com</a>	

**Applications**

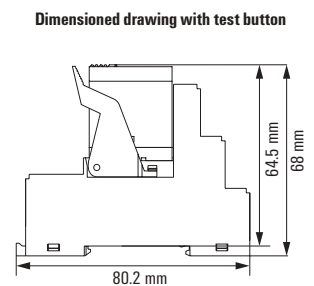
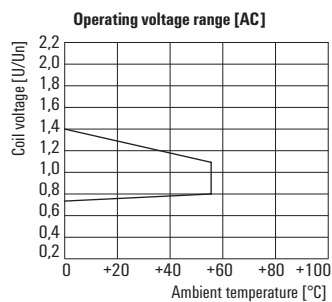
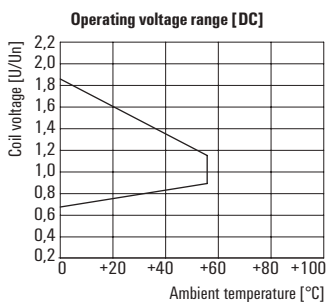
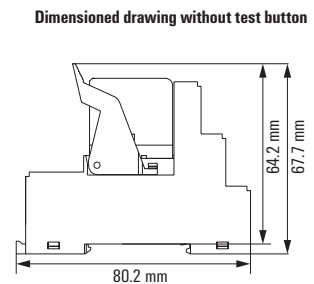
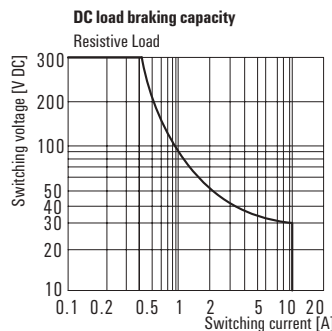
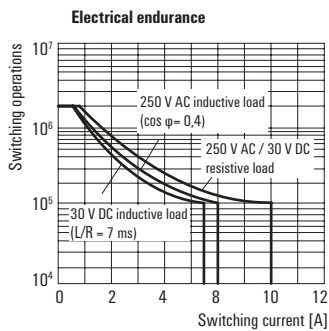

**DRI KIT with screw connection**  
**1 CO contact, AC/DC coil**

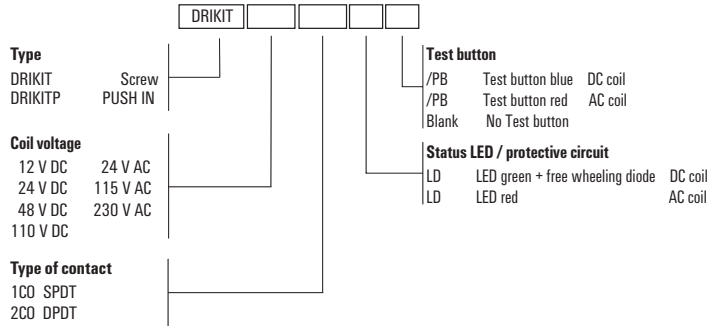

**Ordering data**

Control side	12 V DC 1CO	24 V DC 1CO	48 V DC 1CO	110 V DC 1CO
Rated control voltage	12 V DC	24 V DC	48 V DC	110 V DC
Rated current AC / DC	/ 44,4 mA	/ 21,8 mA	/ 11,2 mA	/ 4,8 mA
Power rating	530 mW	530 mW	530 mW	530 mW
Status indicator	Green LED	Green LED	Green LED	Green LED
Protective circuit	Free-wheeling diode	Free-wheeling diode	Free-wheeling diode	Free-wheeling diode

**Ordering data**

with test button	Type Order No.	DRIKIT 12VDC 1CO LD/PB <b>2476740000</b>	DRIKIT 24VDC 1CO LD/PB <b>2476750000</b>	DRIKIT 48VDC 1CO LD/PB <b>2476760000</b>	DRIKIT 110VDC 1CO LD/PB <b>2476770000</b>
without test button	Type Order No.	DRIKIT 12VDC 1CO LD <b>2476340000</b>	DRIKIT 24VDC 1CO LD <b>2476680000</b>	DRIKIT 48VDC 1CO LD <b>2476690000</b>	DRIKIT 110VDC 1CO LD <b>2476700000</b>
	Type Order No.				
	Type Order No.				

**Note**

**Ordering data**

Control side	24 V AC 1CO	115 V AC 1CO	230 V AC 1CO
Rated control voltage	24 V AC	115 V AC	230 V AC
Rated current AC / DC	50 mA /	9.3 mA /	4,9 mA /
Power rating	1.2 VA	1.1 VA	1.1 VA
Status indicator	red LED	red LED	red LED
Protective circuit			

**Ordering data**

with test button	Type Order No.	DRIKIT 24VAC 1CO LD/PB <b>2476780000</b>	DRIKIT 115VAC 1CO LD/PB <b>2476790000</b>	DRIKIT 230VAC 1CO LD/PB <b>2476800000</b>
without test button	Type Order No.	DRIKIT 24VAC 1CO LD <b>2476710000</b>	DRIKIT 115VAC 1CO LD <b>2476720000</b>	DRIKIT 230VAC 1CO LD <b>2476730000</b>
	Type Order No.			
	Type Order No.			

**Note**

**D-SERIES – relay modules**

**DRI KIT with PUSH IN connection**

**2 CO contact, AC/DC coil**

- Mounted kit consisting relay, socket and retaining clip
- 100 % function tested
- 100 % check of the dielectric strenght between input - output
- Optional: test button with coloured control voltage marking (AC coil: red / DC coil: blue)
- Bright status LED (AC coil: red / DC coil: green)



**Circuit diagram**

**DC coil LED+diode**

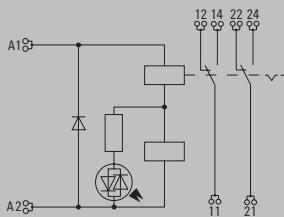

**AC coil LED:**

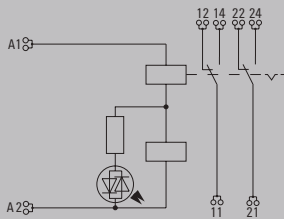

**Technical data**

Load side	
Rated switching voltage / Continuous current	250 V AC / 5 A
Max. switching voltage, AC	250 V
Min. switching power	10 mA @ 24 V, 10 mA @ 12 V, 100 mA @ 5 V
Contact type	2 CO contact (AgSnO)
Mechanical service life	10 x 10 <sup>6</sup> switching cycles
Max. switching frequency at rated load	0.1 Hz
General data	
Ambient temperature (operational)	-40 °C...55 °C
Storage temperature	-40 °C...85 °C
Humidity	35...85 % rel. humidity, no condensation
Approvals	CE, UKCA
Insulation coordinates	
Rated voltage	250 V
Impulse withstand voltage	5 kV (1.2/50 µs)
Dielectric strength for control side - load side	5 kV <sub>eff</sub> / 1min
Dielectric strength of neighbouring contacts	1.5 kV <sub>eff</sub> / 1 min.
Dielectric strength to mounting rail	
Clearance and creepage distances for control side - load side	≥ 3 mm
Overvoltage category	III
Pollution degree	2

Dimensions	PUSH IN
Clamping range (nominal / min. / max.)	mm <sup>2</sup> 1.5 / 0.14 / 1.5
Depth x width x height	see dimensioned drawing
<b>Note</b>	Further technical data can be found at <a href="http://eshop.weidmueller.com">eshop.weidmueller.com</a>

**Applications**

**Electrical endurance**

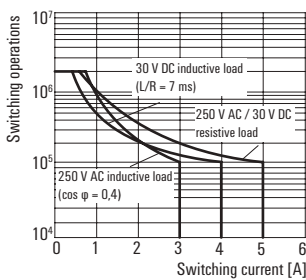

**DC load braking capacity Resistive Load**

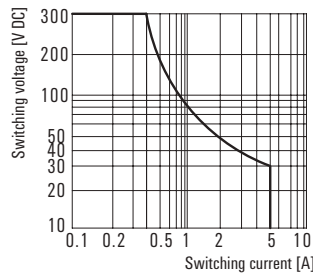

**Dimensioned drawing without test button**

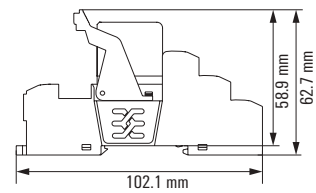

**Operating voltage range [DC]**

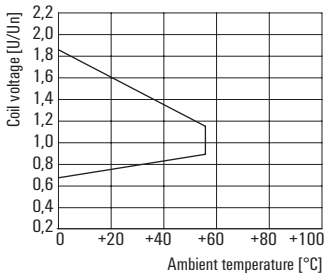

**Operating voltage range [AC]**

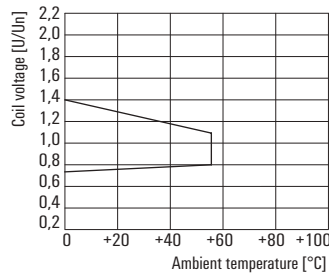

**Dimensioned drawing with test button**

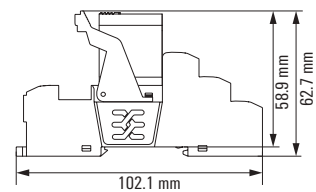

**DRI KIT with PUSH IN connection**  
**2 CO contact, AC/DC coil**

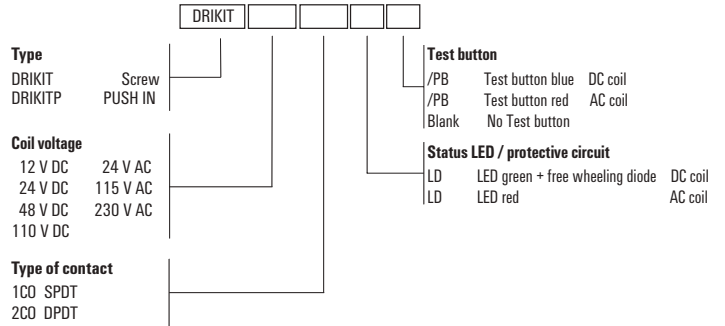

**Ordering data**

Control side	24 V DC 2CO	24 V AC 2CO	115 V AC 2CO	230 V AC 2CO
Rated control voltage	24 V DC	24 V AC	115 V AC	230 V AC
Rated current AC / DC	/ 21,8 mA	50 mA /	9,3 mA /	4,9 mA /
Power rating	530 mW	1,2 VA	1,1 VA	1,1 VA
Status indicator	Green LED	red LED	red LED	red LED
Protective circuit	Free-wheeling diode			

Ordering data		24 V DC 2CO	24 V AC 2CO	115 V AC 2CO	230 V AC 2CO
with test button	Type	DRIKITP 24VDC 2CO LD/PB	DRIKITP 24VAC 2CO LD/PB	DRIKITP 115VAC 2CO LD/PB	DRIKITP 230VAC 2CO LD/PB
	Order No.	<b>2576190000</b>	<b>2576230000</b>	<b>2576170000</b>	<b>2576150000</b>
without test button	Type	DRIKITP 24VDC 2CO LD	DRIKITP 24VAC 2CO LD	DRIKITP 115VAC 2CO LD	DRIKITP 230VAC 2CO LD
	Order No.	<b>2576200000</b>	<b>2576240000</b>	<b>2576290000</b>	<b>2576270000</b>
	Type				
	Order No.				
	Type				
	Order No.				

Note	24 V DC 2CO	24 V AC 2CO	115 V AC 2CO	230 V AC 2CO

**D-SERIES – relay modules**

**DRI KIT with screw connection**

**2 CO contact, AC/DC coil**

- Mounted kit consisting relay, socket and retaining clip
- 100 % function tested
- 100 % check of the dielectric strenght between input - output
- Optional: test button with coloured control voltage marking (AC coil: red / DC coil: blue)
- Bright status LED (AC coil: red / DC coil: green)



**Circuit diagram**

**DC coil LED+diode**

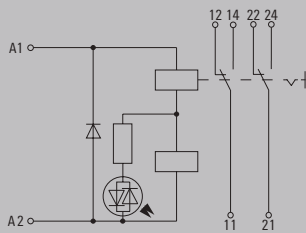

**AC coil bipolar LED:**

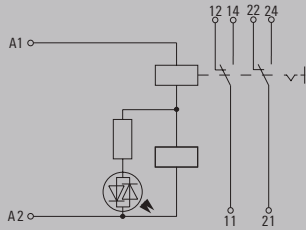

**Technical data**

Load side	
Rated switching voltage / Continuous current	250 V AC / 5 A
Max. switching voltage, AC	250 V
Min. switching power	10 mA @ 24 V, 10 mA @ 12 V, 100 mA @ 5 V
Contact type	2 CO contact (AgSnO)
Mechanical service life	10 x 10 <sup>6</sup> switching cycles
Max. switching frequency at rated load	0.1 Hz
General data	
Ambient temperature (operational)	-40 °C...55 °C
Storage temperature	-40 °C...85 °C
Humidity	35...85 % rel. humidity, no condensation
Approvals	CE, UKCA
Insulation coordinates	
Rated voltage	250 V
Impulse withstand voltage	4.8 kV (1.2/50 µs)
Dielectric strength for control side - load side	4 kV <sub>eff</sub> / 1 min
Dielectric strength of neighbouring contacts	1.5 kV <sub>eff</sub> / 1 min.
Dielectric strength to mounting rail	
Clearance and creepage distances for control side - load side	≥ 3 mm
Overvoltage category	III
Pollution degree	2
Dimensions	
Clamping range (nominal / min. / max.)	mm <sup>2</sup> 1.5 / 0.25 / 4
Depth x width x height	see dimensioned drawing
Note	
Further technical data can be found at <a href="http://eshop.weidmueller.com">eshop.weidmueller.com</a>	

**Applications**

**Electrical endurance**

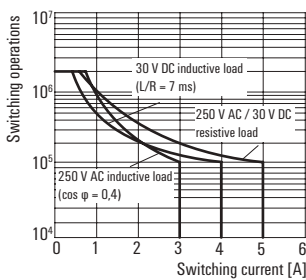

**DC load braking capacity**

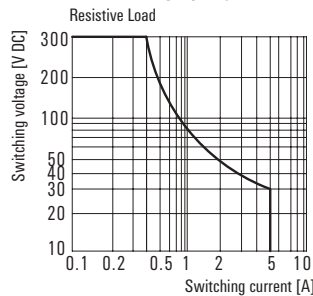

**Dimensioned drawing without test button**

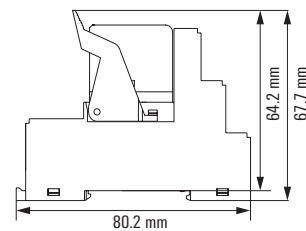

**Operating voltage range [DC]**

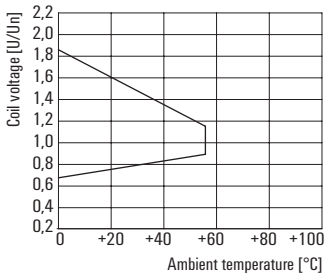

**Operating voltage range [AC]**

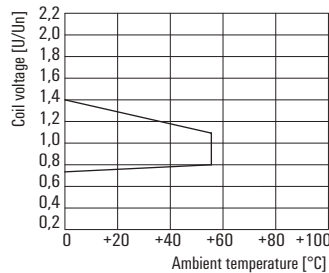

**Dimensioned drawing with test button**

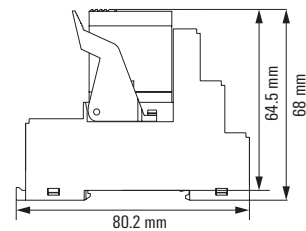

**DRI KIT with screw connection**  
**2 CO contact, AC/DC coil**

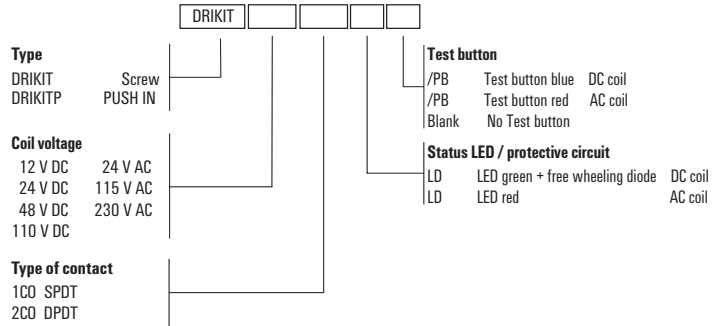

**Ordering data**

Control side	12 V DC 2CO	24 V DC 2CO	48 V DC 2CO	110 V DC 2CO
Rated control voltage	12 V DC	24 V DC	48 V DC	110 V DC
Rated current AC / DC	/ 44,4 mA	/ 21,8 mA	/ 11,2 mA	/ 4,8 mA
Power rating	530 mW	530 mW	530 mW	530 mW
Status indicator	Green LED	Green LED	Green LED	Green LED
Protective circuit	Free-wheeling diode	Free-wheeling diode	Free-wheeling diode	Free-wheeling diode

Ordering data	12 V DC 2CO	24 V DC 2CO	48 V DC 2CO	110 V DC 2CO
with test button	Type: DRIKIT 12VDC 2CO LD/PB Order No. <b>2476880000</b>	Type: DRIKIT 24VDC 2CO LD/PB Order No. <b>2476890000</b>	Type: DRIKIT 48VDC 2CO LD/PB Order No. <b>2476900000</b>	Type: DRIKIT 110VDC 2CO LD/PB Order No. <b>2476910000</b>
without test button	Type: DRIKIT 12VDC 2CO LD Order No. <b>2476810000</b>	Type: DRIKIT 24VDC 2CO LD Order No. <b>2476820000</b>	Type: DRIKIT 48VDC 2CO LD Order No. <b>2476830000</b>	Type: DRIKIT 110VDC 2CO LD Order No. <b>2476840000</b>
	Type: Order No. 	Type: Order No. 	Type: Order No. 	Type: Order No. 
	Type: Order No. 	Type: Order No. 	Type: Order No. 	Type: Order No. 

Note	12 V DC 2CO	24 V DC 2CO	48 V DC 2CO	110 V DC 2CO

**Ordering data**

Control side	24 V AC 2CO	115 V AC 2CO	230 V AC 2CO
Rated control voltage	24 V AC	115 V AC	230 V AC
Rated current AC / DC	50 mA /	9.3 mA /	4,9 mA /
Power rating	1.2 VA	1.1 VA	1.1 VA
Status indicator	red LED	red LED	red LED
Protective circuit			

Ordering data	24 V AC 2CO	115 V AC 2CO	230 V AC 2CO
with test button	Type: DRIKIT 24VAC 2CO LD/PB Order No. <b>2476920000</b>	Type: DRIKIT 115VAC 2CO LD/PB Order No. <b>2476930000</b>	Type: DRIKIT 230VAC 2CO LD/PB Order No. <b>2476940000</b>
without test button	Type: DRIKIT 24VAC 2CO LD Order No. <b>2476850000</b>	Type: DRIKIT 115VAC 2CO LD Order No. <b>2476860000</b>	Type: DRIKIT 230VAC 2CO LD Order No. <b>2476870000</b>
	Type: Order No. 	Type: Order No. 	Type: Order No. 
	Type: Order No. 	Type: Order No. 	Type: Order No. 

Note	24 V AC 2CO	115 V AC 2CO	230 V AC 2CO

DRI relay

1 CO contact, AC/DC coil

- Robust industrial plug-in connections
- Optional: latching / spring return operable test button with coloured control voltage identification (AC coil: red / DC coil: blue)
- Optional: Bright status LED (AC coil: red / DC coil: green)
- Optional: free-wheeling diode



Technical data

Load side	
Rated switching voltage / Continuous current	250 V AC / 10 A
Max. switching voltage, AC	250 V
Min. switching power	10 mA @ 24 V, 10 mA @ 12 V, 100 mA @ 5 V
Mechanical service life	10 x 10 <sup>6</sup> switching cycles
Max. switching frequency at rated load	0.1 Hz
General data	
Ambient temperature (operational)	-40 °C...55 °C
Storage temperature	-40 °C...85 °C
Humidity	35...85 % rel. humidity, no condensation
Approvals	cURus
Insulation coordinates	
Rated voltage	300 V
Impulse withstand voltage	5 kV (1.2/50 µs)
Dielectric strength for control side - load side	5 kV <sub>eff</sub> / 1min
Dielectric strength of neighbouring contacts	
Dielectric strength to mounting rail	
Clearance and creepage distances for control side - load side	≥ 4 mm
Overvoltage category	III
Pollution degree	2
Dimensions	
Depth x width x height	Flat blade connections (4.7 mm x 0.5 mm) see dimensioned drawing
Note	
Further technical data can be found at <a href="http://eshop.weidmueller.com">eshop.weidmueller.com</a>	

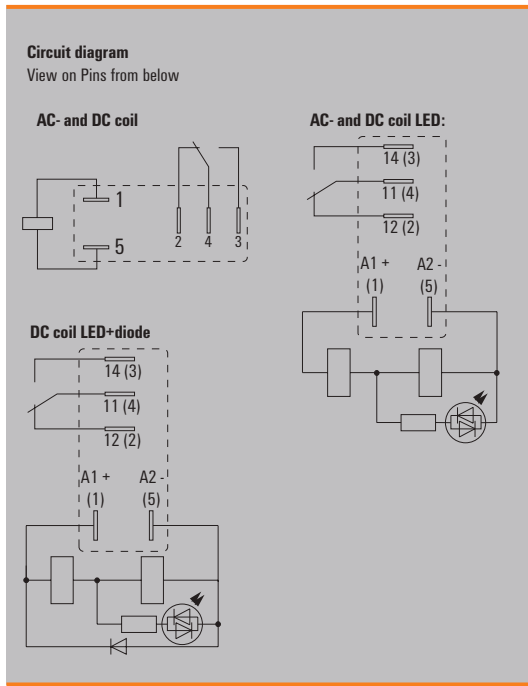

Applications

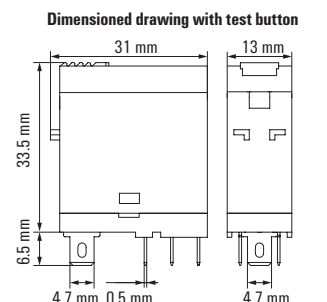
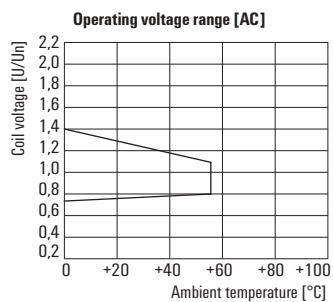
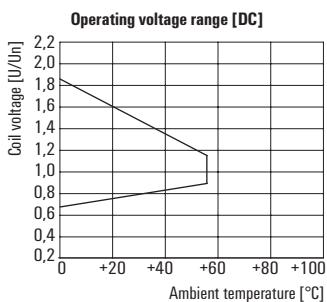
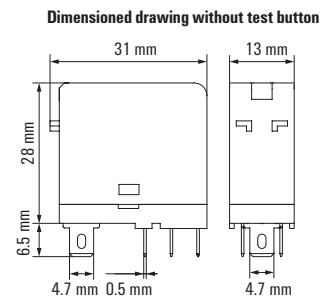
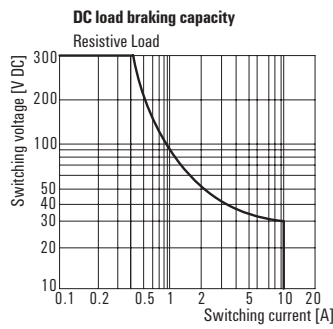
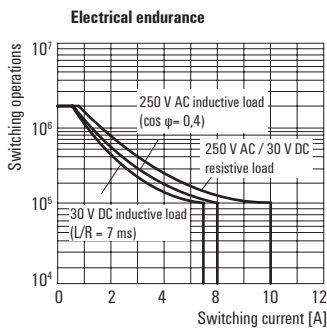

**DRI relay**  
**1 CO contact, AC/DC coil**

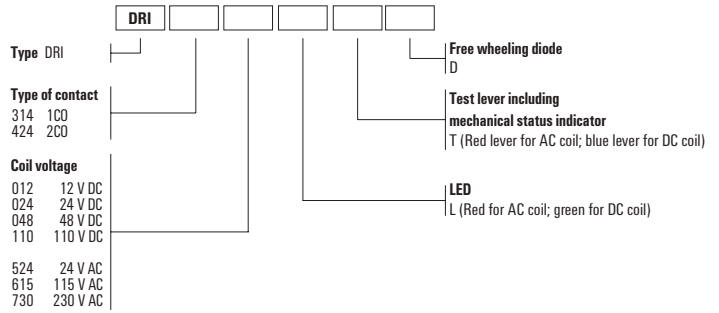

**Ordering data**

		12 V DC 1CO	24 V DC 1CO	48 V DC 1CO	110 V DC 1CO
<b>Control side</b>					
Rated control voltage		12 V DC	24 V DC	48 V DC	110 V DC
Rated current AC / DC		/ 44,4 mA	/ 21,8 mA	/ 11,2 mA	/ 4,8 mA
Power rating		530 mW	530 mW	530 mW	530 mW
<b>Ordering data</b>					
Standard	Type	DRI314012	DRI314024	DRI314048	DRI314110L
	Order No.	<b>7760056296</b>	<b>7760056297</b>	<b>7760056298</b>	<b>7760056306</b>
with LED	Type	DRI314012L	DRI314024L	DRI314048L	DRI314110LD
	Order No.	<b>7760056303</b>	<b>7760056304</b>	<b>7760056305</b>	<b>7760056313</b>
with LED + free-wheeling diode	Type	DRI314012LD	DRI314024LD	DRI314048LD	DRI314110LTD
	Order No.	<b>7760056310</b>	<b>7760056311</b>	<b>7760056312</b>	<b>7760056317</b>
with test button + LED	Type	DRI314012LTD	DRI314024LTD	DRI314048LTD	
+ Free-wheel diode	Order No.	<b>7760056314</b>	<b>7760056315</b>	<b>7760056316</b>	

<b>Note</b>					
-------------	--	--	--	--	--

**Ordering data**

		24 V AC 1CO	115 V AC 1CO	230 V AC 1 CO
<b>Control side</b>				
Rated control voltage		24 V AC	115 V AC	230 V AC
Rated current AC / DC		50 mA /	9,3 mA /	4,9 mA /
Power rating		1.2 VA	1.1 VA	1.1 VA
<b>Ordering data</b>				
Standard	Type	DRI314524	DRI314615	DRI314730
	Order No.	<b>7760056300</b>	<b>7760056301</b>	<b>7760056302</b>
with LED	Type	DRI314524L	DRI314615L	DRI314730L
	Order No.	<b>7760056307</b>	<b>7760056308</b>	<b>7760056309</b>
with test button + LED	Type	DRI314524LT	DRI314615LT	DRI314730LT
	Order No.	<b>7760056318</b>	<b>7760056319</b>	<b>7760056320</b>
	Type			
	Order No.			

<b>Note</b>				
-------------	--	--	--	--

Accessories for DRI relays

- Flat design
- DIN rail unlocked using screwdriver

Technical data

<b>Load side</b>	
Rated switching voltage	250 V AC
Max. switching voltage, AC	250 V
Continuous current	12 A
<b>General data</b>	
Ambient temperature (operational)	-40 °C...55 °C
Storage temperature	-40 °C...85 °C
Approvals	CE; cURus; UKCA
<b>Insulation coordinates</b>	
Protection degree	IP20
Clearance and creepage distances for control side - load side	≥ 3 mm
Dielectric strength for control side - load side	5 kV <sub>eff</sub> / 1min
Dielectric strength of neighbouring contacts	
Impulse withstand voltage	4.8 kV (1.2/50 µs)
<b>Connection data</b>	
Clamping range (nominal / min. / max.)	1.5 / 0.14 / 1.5 mm <sup>2</sup>
Tightening torque	...
Stripping length, rated connection	10 mm
<b>Note</b>	

Ordering data

	Plug-in module on TS35 terminal rail
<b>Note</b>	

Accessories

<b>LED module / protection modules</b>	
Free-wheeling diode 6 - 230 V DC	
LED 6 - 24 V DC green and freewheeling diode	
LED 24 - 60 V DC green and free-wheeling diode	
LED 110 - 230 V DC green and free-wheeling diode	
LED 6 - 24 V UC green	
LED 24 - 60 V UC green	
LED 110 - 230 V UC green	
RC element 110 - 230 V AC; 4.7 kΩ / 10 nF	
RC element 110 - 230 V AC; 100 Ω / 220 nF and LED green	
<b>Cross-connector</b>	
<b>Retaining clip</b>	
Plastic retaining clip	
Plastic retaining bracket with marker holder	
Metal retaining clip for relay with test button	
Metal bracket for relay without test button	
<b>Marking tags</b>	white
<b>Screwdriver</b>	
Standard, uninsulated	
Standard, insulated	

**Note**

Socket with PUSH IN connection, 1 CO contact

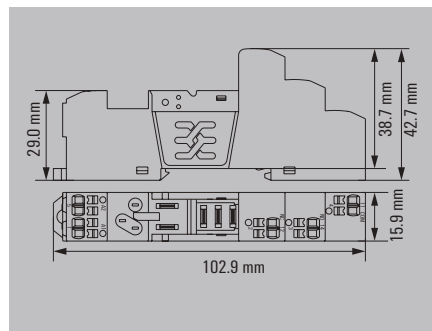

<b>Load side</b>	
Rated switching voltage	250 V AC
Max. switching voltage, AC	250 V
Continuous current	12 A
<b>General data</b>	
Ambient temperature (operational)	-40 °C...55 °C
Storage temperature	-40 °C...85 °C
Approvals	CE; cURus; UKCA
<b>Insulation coordinates</b>	
Protection degree	IP20
Clearance and creepage distances for control side - load side	≥ 3 mm
Dielectric strength for control side - load side	5 kV <sub>eff</sub> / 1min
Dielectric strength of neighbouring contacts	
Impulse withstand voltage	4.8 kV (1.2/50 µs)
<b>Connection data</b>	
Clamping range (nominal / min. / max.)	1.5 / 0.14 / 1.5 mm <sup>2</sup>
Tightening torque	...
Stripping length, rated connection	10 mm
<b>Note</b>	

Type	Qty.	Order No.
SDI 1CO P	20	7760056364

Type	Qty.	Order No.
RIM 1 6/230VDC	10	7760056169
RIM 2 6/24VDC	10	7760056015
RIM 2 24/60VDC	10	7760056016
RIM 2 110/230VDC	10	7760056017
RIM 3 6/24VUC	10	7940018457
RIM 3 24/60VUC	10	7760056018
RIM 3 110/230VUC	10	7940018455
RIM 3 110/230VAC	10	7760056014
SCM/SDI P CC	10	7760056366
SDI CLIP	10	7760056352
SDI CLIP P	10	7760056389
SDI CLIP HM	10	7760056390
SDI CLIP LM	10	7760056368
ESG 6/15 SDI MC NE WS	200	2558340000
SDS 0.4X2.5X75	1	2749320000
SDIS 0.4X2.5X75	1	2749790000

Further accessories can be found on the article at [eshop.weidmueller.com](http://eshop.weidmueller.com)

Socket with clamping yoke connection, 1 CO contact

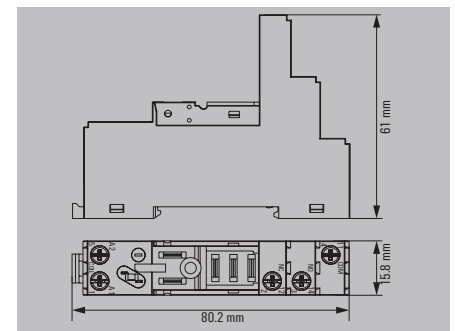

<b>Load side</b>	
Rated switching voltage	250 V AC
Max. switching voltage, AC	250 V
Continuous current	12 A
<b>General data</b>	
Ambient temperature (operational)	-40 °C...70 °C
Storage temperature	-40 °C...85 °C
Approvals	CE; cURus
<b>Insulation coordinates</b>	
Protection degree	IP20
Clearance and creepage distances for control side - load side	≥ 3 mm
Dielectric strength for control side - load side	4 kV <sub>eff</sub> / 1 Min.
Dielectric strength of neighbouring contacts	
Impulse withstand voltage	4.8 kV (1.2/50 µs)
<b>Connection data</b>	
Clamping range (nominal / min. / max.)	1.5 / 0.25 / 4 mm <sup>2</sup>
Tightening torque	0.5...0.8 Nm
Stripping length, rated connection	8 mm
<b>Note</b>	

Type	Qty.	Order No.
SDI 1CO	10	7760056350

Type	Qty.	Order No.
RIM 1 6/230VDC	10	7760056169
RIM 2 6/24VDC	10	7760056015
RIM 2 24/60VDC	10	7760056016
RIM 2 110/230VDC	10	7760056017
RIM 3 6/24VUC	10	7940018457
RIM 3 24/60VUC	10	7760056018
RIM 3 110/230VUC	10	7940018455
RIM 3 110/230VAC	10	7760056014
RIM 3 110/230VAC LED	10	7760056045
SRC-I QV S	10	1132070000
SDI CLIP	10	7760056352
SDI CLIP P	10	7760056389
SDI CLIP HM	10	7760056390
SDI CLIP LM	10	7760056368
ESG 6/15 SDI MC NE WS	200	2558340000
SDK PH1 X 80	1	2749410000
SDIK PH1 X 80	1	2749890000

Further accessories can be found on the article at [eshop.weidmueller.com](http://eshop.weidmueller.com)

**Socket with pressure clamping plate, 1 CO contact**

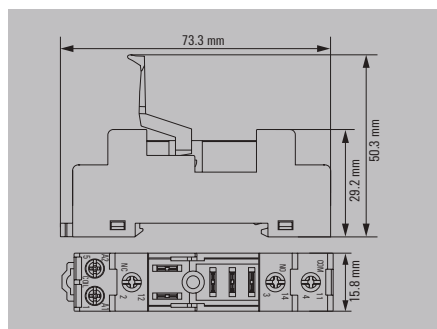

250 V AC
250 V
12 A
-40 °C...70 °C
-40 °C...85 °C
CE
IP20
≥ 3 mm
4 kV <sub>eff</sub> / 1 Min.
4.8 kV (1.2/50 μs)
1.5 / 0.5 / 2.5 mm <sup>2</sup>
0.5...0.8 Nm
8 mm

Type	Qty.	Order No.
SDI 1CO F ECO	10	7760056348

Type	Qty.	Order No.
SDK PH1 X 80	1	2749410000
SDK PH1 X 80	1	2749890000

LED and protective modules are not compatible with this base. Further accessories can be found on the article at [eshop.weidmuller.com](http://eshop.weidmuller.com)

**D-SERIES – relay modules**

**DRI relay**

**2 CO contacts, AC/DC coil**

- Robust industrial plug-in connections
- Optional: latching / spring return operable test button with coloured control voltage identification (AC coil: red / DC coil: blue)
- Optional: Bright status LED (AC coil: red / DC coil: green)
- Optional: free-wheeling diode



**Technical data**

Load side	
Rated switching voltage / Continuous current	250 V AC / 5 A
Max. switching voltage, AC	250 V
Min. switching power	10 mA @ 24 V, 10 mA @ 12 V, 100 mA @ 5 V
Mechanical service life	10 x 10 <sup>6</sup> switching cycles
Max. switching frequency at rated load	0.1 Hz
General data	
Ambient temperature (operational)	-40 °C...55 °C
Storage temperature	-40 °C...85 °C
Humidity	35...85 % rel. humidity, no condensation
Approvals	cURus
Insulation coordinates	
Rated voltage	300 V
Impulse withstand voltage	5 kV (1.2/50 µs)
Dielectric strength for control side - load side	5 kV <sub>eff</sub> / 1min
Dielectric strength of neighbouring contacts	1.5 kV <sub>eff</sub> / 1 min.
Dielectric strength to mounting rail	
Clearance and creepage distances for control side - load side	≥ 4 mm
Overvoltage category	III
Pollution degree	2
Dimensions	
Depth x width x height	Flat blade connections (2.5 mm x 0.5 mm) see dimensioned drawing
Note	
Further technical data can be found at <a href="http://eshop.weidmueller.com">eshop.weidmueller.com</a>	

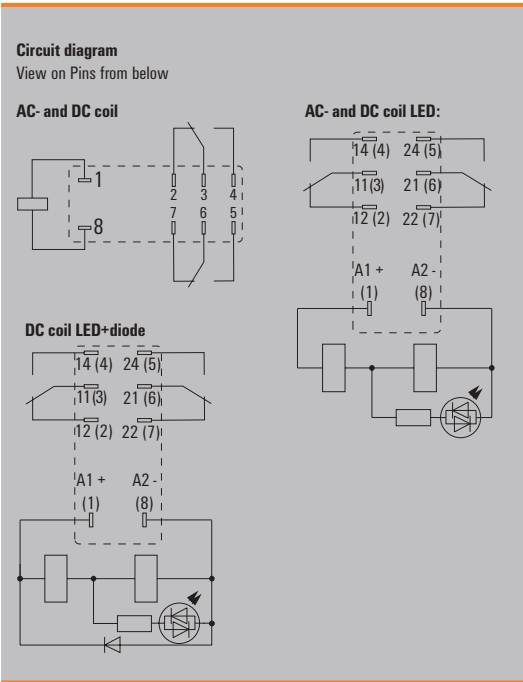

**Applications**

**Electrical endurance**

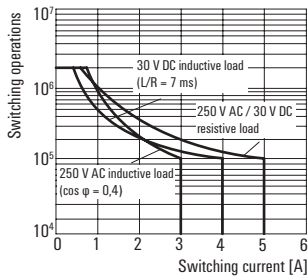

**DC load braking capacity**  
Resistive Load

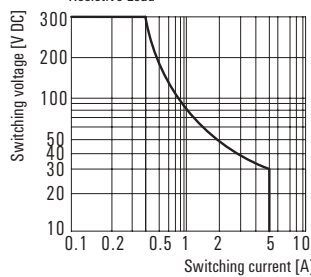

**Dimensioned drawing without test button**

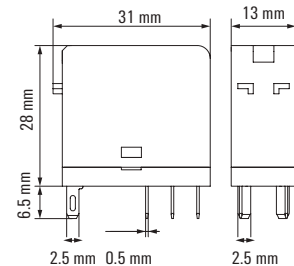

**Operating voltage range [DC]**

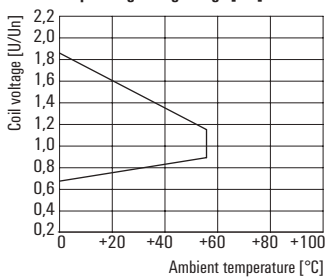

**Operating voltage range [AC]**

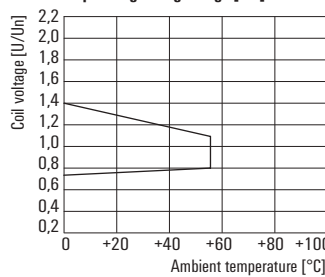

**Dimensioned drawing with test button**

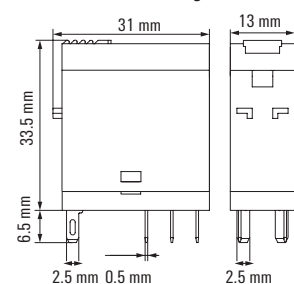

**DRI relay**  
**2 CO contacts, AC/DC coil**

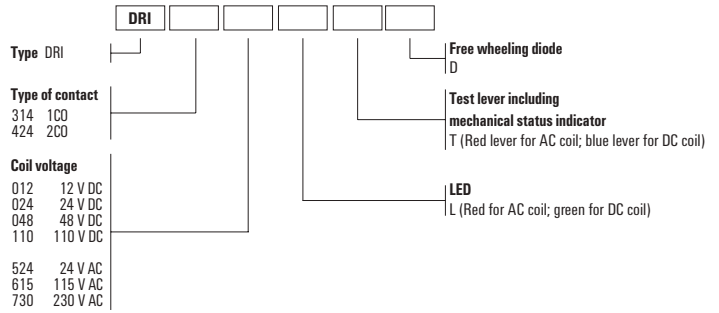

**Ordering data**

		12 V DC 2CO	24 V DC 2CO	48 V DC 2CO	110 V DC 2CO
<b>Control side</b>					
Rated control voltage		12 V DC	24 V DC	48 V DC	110 V DC
Rated current AC / DC		/ 44,4 mA	/ 21,8 mA	/ 11,2 mA	/ 4,8 mA
Power rating		530 mW	530 mW	530 mW	530 mW
<b>Ordering data</b>					
Standard	Type	DRI424012	DRI424024	DRI424048	DRI424110
	Order No.	<b>7760056321</b>	<b>7760056322</b>	<b>7760056323</b>	<b>7760056324</b>
with LED	Type	DRI424012L	DRI424024L	DRI424048L	DRI424110L
	Order No.	<b>7760056328</b>	<b>7760056329</b>	<b>7760056330</b>	<b>7760056331</b>
with LED + free-wheeling diode	Type	DRI424012LD	DRI424024LD	DRI424048LD	DRI424110LD
	Order No.	<b>7760056335</b>	<b>7760056336</b>	<b>7760056337</b>	<b>7760056338</b>
with test button + LED	Type	DRI424012LTD	DRI424024LTD	DRI424048LTD	DRI424110LTD
+ Free-wheel diode	Order No.	<b>7760056339</b>	<b>7760056340</b>	<b>7760056341</b>	<b>7760056342</b>

<b>Note</b>				
-------------	--	--	--	--

**Ordering data**

		24 V AC 2CO	115 V AC 2CO	230 V AC 2CO
<b>Control side</b>				
Rated control voltage		24 V AC	115 V AC	230 V AC
Rated current AC / DC		50 mA /	9.3 mA /	4,9 mA /
Power rating		1.2 VA	1.1 VA	1.1 VA
<b>Ordering data</b>				
Standard	Type	DRI424524	DRI424615	DRI424730
	Order No.	<b>7760056325</b>	<b>7760056326</b>	<b>7760056327</b>
with LED	Type	DRI424524L	DRI424615L	DRI424730L
	Order No.	<b>7760056332</b>	<b>7760056333</b>	<b>7760056334</b>
with test button + LED	Type	DRI424524LT	DRI424615LT	DRI424730LT
	Order No.	<b>7760056343</b>	<b>7760056344</b>	<b>7760056345</b>
	Type			
	Order No.			

<b>Note</b>			
-------------	--	--	--

Accessories for DRI relays

- Flat design
- DIN rail unlocked using screwdriver

Technical data

<b>Load side</b>	
Rated switching voltage	250 V AC
Max. switching voltage, AC	250 V
Continuous current	8 A
<b>General data</b>	
Ambient temperature (operational)	-40 °C...55 °C
Storage temperature	-40 °C...85 °C
Approvals	CE; cURus; UKCA
<b>Insulation coordinates</b>	
Protection degree	IP20
Clearance and creepage distances for control side - load side	≥ 3 mm
Dielectric strength for control side - load side	5 kV <sub>eff</sub> / 1 min
Dielectric strength of neighbouring contacts	2.5 kV <sub>eff</sub> / 1 Min.
Impulse withstand voltage	4.8 kV (1.2/50 µs)
<b>Connection data</b>	
Clamping range (nominal / min. / max.)	1.5 / 0.14 / 1.5 mm <sup>2</sup>
Tightening torque	...
Stripping length, rated connection	10 mm
<b>Note</b>	

Ordering data

	Plug-in module on TS35 terminal rail
<b>Note</b>	

Accessories

<b>LED module / protection modules</b>	
Free-wheeling diode 6 - 230 V DC	
LED 6 - 24 V DC green and freewheeling diode	
LED 24 - 60 V DC green and free-wheeling diode	
LED 110 - 230 V DC green and free-wheeling diode	
LED 6 - 24 V UC green	
LED 24 - 60 V UC green	
LED 110 - 230 V UC green	
RC element 110 - 230 V AC; 4.7 kΩ / 10 nF	
RC element 110 - 230 V AC; 100 Ω / 220 nF and LED green	
<b>Cross-connector</b>	
<b>Retaining clip</b>	
Plastic retaining clip	
Plastic retaining bracket with marker holder	
Metal retaining clip for relay with test button	
Metal bracket for relay without test button	
<b>Marking tags</b>	white
<b>Screwdriver</b>	
Standard, uninsulated	
Standard, insulated	

**Note**

Socket with PUSH IN connection, 2 CO contact

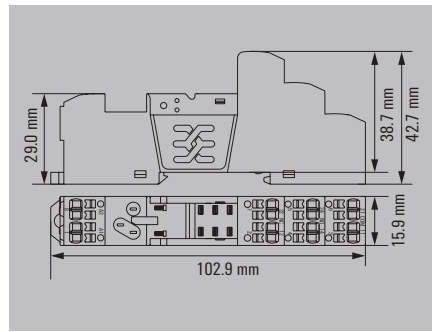

<b>Load side</b>	
Rated switching voltage	250 V AC
Max. switching voltage, AC	250 V
Continuous current	8 A
<b>General data</b>	
Ambient temperature (operational)	-40 °C...55 °C
Storage temperature	-40 °C...85 °C
Approvals	CE; cURus; UKCA
<b>Insulation coordinates</b>	
Protection degree	IP20
Clearance and creepage distances for control side - load side	≥ 3 mm
Dielectric strength for control side - load side	5 kV <sub>eff</sub> / 1 min
Dielectric strength of neighbouring contacts	2.5 kV <sub>eff</sub> / 1 Min.
Impulse withstand voltage	4.8 kV (1.2/50 µs)
<b>Connection data</b>	
Clamping range (nominal / min. / max.)	1.5 / 0.14 / 1.5 mm <sup>2</sup>
Tightening torque	...
Stripping length, rated connection	10 mm
<b>Note</b>	

Type	Qty.	Order No.
SDI 2CO P	20	7760056365

Type	Qty.	Order No.
RIM 1 6/230VDC	10	7760056169
RIM 2 6/24VDC	10	7760056015
RIM 2 24/60VDC	10	7760056016
RIM 2 110/230VDC	10	7760056017
RIM 3 6/24VUC	10	7940018457
RIM 3 24/60VUC	10	7760056018
RIM 3 110/230VUC	10	7940018455
RIM 3 110/230VAC	10	7760056014
SCM/SDI P CC	10	7760056366
SDI CLIP	10	7760056352
SDI CLIP P	10	7760056389
SDI CLIP HM	10	7760056390
SDI CLIP LM	10	7760056368
ESG 6/15 SDI MC NE WS	200	2558340000
SDS 0.4X2.5X75	1	2749320000
SDIS 0.4X2.5X75	1	2749790000

Further accessories can be found on the article at [eshop.weidmueller.com](http://eshop.weidmueller.com)

Socket with clamping yoke connection, 2 CO contacts

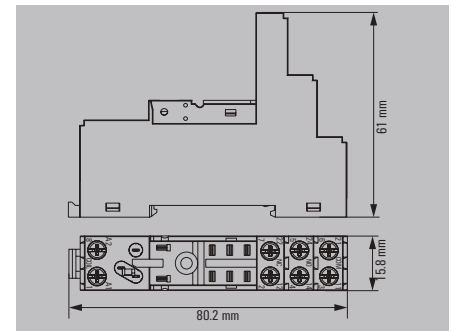

<b>Load side</b>	
Rated switching voltage	250 V AC
Max. switching voltage, AC	250 V
Continuous current	8 A
<b>General data</b>	
Ambient temperature (operational)	-40 °C...70 °C
Storage temperature	-40 °C...85 °C
Approvals	CE; cURus
<b>Insulation coordinates</b>	
Protection degree	IP20
Clearance and creepage distances for control side - load side	≥ 3 mm
Dielectric strength for control side - load side	4 kV <sub>eff</sub> / 1 Min.
Dielectric strength of neighbouring contacts	2.5 kV <sub>eff</sub> / 1 Min.
Impulse withstand voltage	4.8 kV (1.2/50 µs)
<b>Connection data</b>	
Clamping range (nominal / min. / max.)	1.5 / 0.25 / 4 mm <sup>2</sup>
Tightening torque	0.5...0.8 Nm
Stripping length, rated connection	8 mm
<b>Note</b>	

Type	Qty.	Order No.
SDI 2CO	10	7760056351

Type	Qty.	Order No.
RIM 1 6/230VDC	10	7760056169
RIM 2 6/24VDC	10	7760056015
RIM 2 24/60VDC	10	7760056016
RIM 2 110/230VDC	10	7760056017
RIM 3 6/24VUC	10	7940018457
RIM 3 24/60VUC	10	7760056018
RIM 3 110/230VUC	10	7940018455
RIM 3 110/230VAC	10	7760056014
RIM 3 110/230VAC LED	10	7760056045
SRC-I QV S	10	1132070000
SDI CLIP	10	7760056352
SDI CLIP P	10	7760056389
SDI CLIP HM	10	7760056390
SDI CLIP LM	10	7760056368
ESG 6/15 SDI MC NE WS	200	2558340000
SDK PH1 X 80	1	2749410000
SDIK PH1 X 80	1	2749890000

Further accessories can be found on the article at [eshop.weidmueller.com](http://eshop.weidmueller.com)

**Socket with pressure clamping plate, 2 CO contacts**

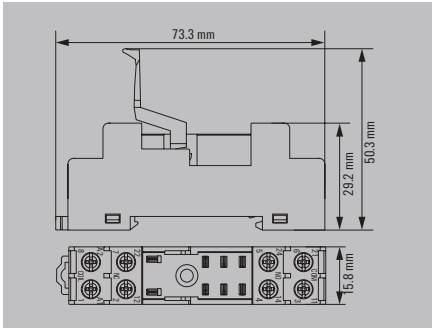

250 V AC
250 V
8 A
-40 °C...70 °C
-40 °C...85 °C
CE
IP20
≥ 3 mm
4 kV <sub>eff</sub> / 1 Min.
2.5 kV <sub>eff</sub> / 1 Min.
4.8 kV (1.2/50 μs)
1.5 / 0.5 / 2.5 mm <sup>2</sup>
0.5...0.8 Nm
8 mm

Type	Qty.	Order No.
SDI 2CO F ECO	10	<b>7760056349</b>

Type	Qty.	Order No.
SDK PH1 X 80	1	<b>2749410000</b>
SDIK PH1 X 80	1	<b>2749890000</b>

LED and protective modules are not compatible with this base. Further accessories can be found on the article at [eshop.weidmueller.com](http://eshop.weidmueller.com)

## D-SERIES – relay modules

### DRM KIT with PUSH IN connection

#### 2 CO contact

- Mounted kit consisting relay, socket and retaining clip
- 100 % function tested
- 100 % check of the dielectric strenght between input - output
- Mechanical status indicator
- Bright status LED (AC coil: red, DC coil: green)
- Optional: test button with coloured control voltage marking (AC coil: red, DC coil: blue)



## B

#### Circuit diagram

##### DC-Version

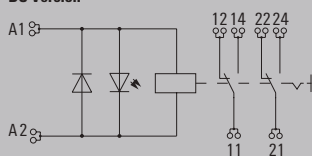

##### AC-Version

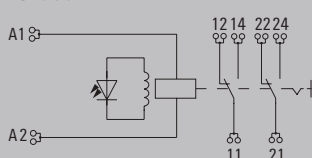

#### Technical data

Load side	
Rated switching voltage / Continuous current	250 V AC / 10 A
Max. switching voltage, AC	250 V
Min. switching power	10 mA @ 12 V, 100 mA @ 5 V
Mechanical service life	20 x 10 <sup>6</sup> switching cycles
Max. switching frequency at rated load	0.1 Hz
General data	
Ambient temperature (operational)	-40 °C...60 °C
Storage temperature	-40 °C...70 °C
Humidity	35...85 % rel. humidity, no condensation
Approvals	CE; UKCA
Insulation coordinates	
Rated voltage	250 V
Impulse withstand voltage	
Dielectric strength for control side - load side	1.8 kV <sub>eff</sub> / 1 min.
Dielectric strength of neighbouring contacts	1 kV <sub>eff</sub> / 1 min
Dielectric strength to mounting rail	
Clearance and creepage distances for control side - load side	≥ 5.5 mm
Overvoltage category	III
Pollution degree	2

Dimensions	PUSH IN
Depth x width x height	see dimensioned drawing

**Note** Further technical data can be found at [eshop.weidmueller.com](http://eshop.weidmueller.com)

### Applications

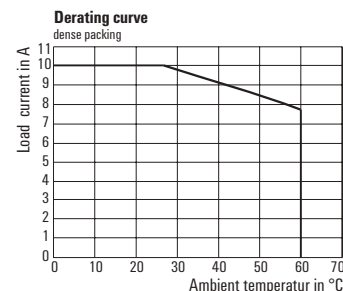
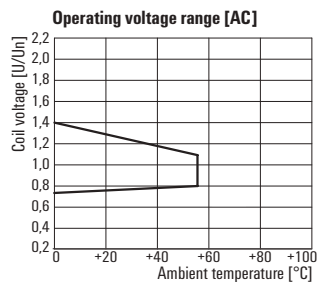
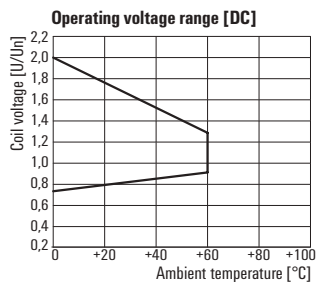
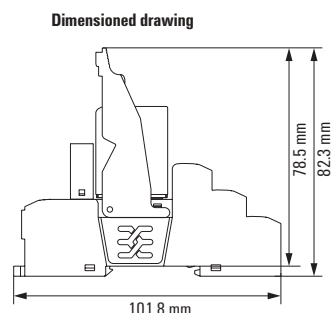
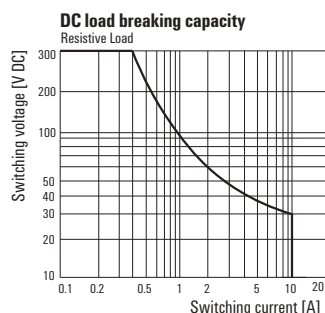
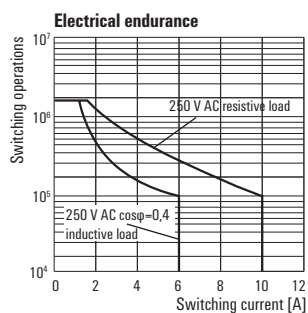

**DRM KIT with PUSH IN connection**  
**2 CO contact**

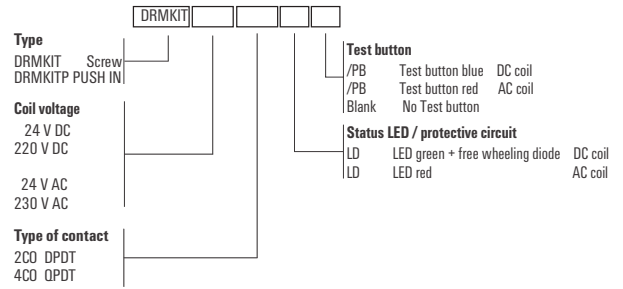

**Ordering data**

Control side	24 V DC	24 V AC	115 V AC	230 V AC
Rated control voltage	24 V DC	24 V AC	115 V AC	230 V AC
Rated current AC / DC	/ 36.9 mA	62.4 mA (50 Hz) /	12.6 mA (50 Hz), 10.8 mA (60 Hz) /	6.1 mA (50 Hz), 5.2 mA (60 Hz) /
Power rating	0.9 W	1.0...1.2VA (60HZ)	1.0...1.2VA (60HZ)	1.0...1.2VA (60HZ)
Status indicator	Green LED	red LED	red LED	red LED
Protective circuit	Free-wheeling diode			

Ordering data	24 V DC	24 V AC	115 V AC	230 V AC
with test button	Type DRMKITP 24VDC 2CO LD/PB	Type DRMKITP 24VAC 2CO LD/PB	Type DRMKITP115VAC 2CO LD/PB	Type DRMKITP230VAC 2CO LD/PB
	Order No. <b>2576120000</b>	Order No. <b>2576080000</b>	Order No. <b>2576000000</b>	Order No. <b>2576040000</b>
without test button	Type DRMKITP 24VDC 2CO LD	Type DRMKITP 24VAC 2CO LD	Type DRMKITP 115VAC 2CO LD	Type DRMKITP 230VAC 2CO LD
	Order No. <b>2576110000</b>	Order No. <b>2576070000</b>	Order No. <b>2575990000</b>	Order No. <b>2576030000</b>

Note	24 V DC	24 V AC	115 V AC	230 V AC

## D-SERIES – relay modules

### DRM KIT with screw connection

#### 2 CO contacts

- Mounted kit consisting relay, socket and retaining clip
- 100 % function tested
- 100 % check of the dielectric strenght between input - output
- Mechanical status indicator
- Bright status LED (AC coil: red, DC coil: green)
- Optional: test button with coloured control voltage marking (AC coil: red, DC coil: blue)



## B

#### Circuit diagram

##### DC-Version

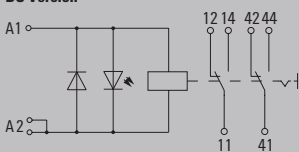

##### AC-Version

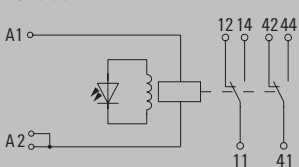

### Technical data

Load side	
Rated switching voltage / Continuous current	250 V AC / 10 A
Max. switching voltage, AC	250 V
Min. switching power	10 mA @ 12 V, 100 mA @ 5 V
Mechanical service life	20 x 10 <sup>6</sup> switching cycles
Max. switching frequency at rated load	0.1 Hz
General data	
Ambient temperature (operational)	-40 °C...60 °C
Storage temperature	-40 °C...70 °C
Humidity	
Approvals	CE; UKCA
Insulation coordinates	
Rated voltage	250 V
Impulse withstand voltage	4.8 kV (1.2/50 µs)
Dielectric strength for control side - load side	1.8 kV <sub>eff</sub> / 1 min.
Dielectric strength of neighbouring contacts	1 kV <sub>eff</sub> / 1 min
Dielectric strength to mounting rail	
Clearance and creepage distances for control side - load side	≥ 5.5 mm
Overvoltage category	III
Pollution degree	2
Dimensions	
Depth x width x height	see dimensioned drawing
Screw connection	
	see dimensioned drawing
Note	
	Further technical data can be found at <a href="http://eshop.weidmuller.com">eshop.weidmuller.com</a>

### Applications

#### Electrical endurance

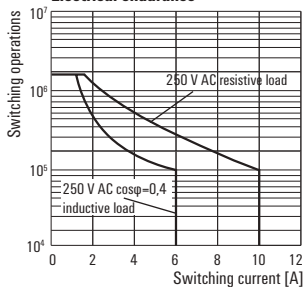

#### DC load breaking capacity

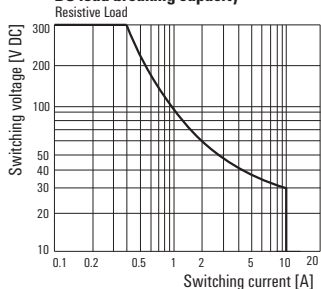

#### Dimensioned drawing

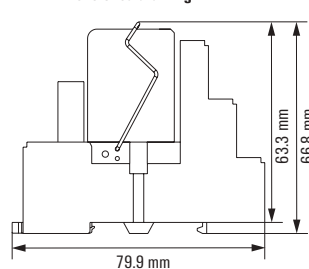

#### Operating voltage range [DC]

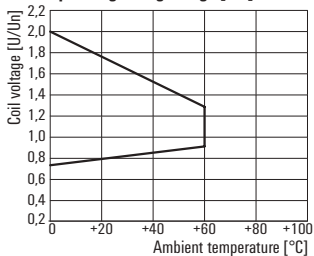

#### Operating voltage range [AC]

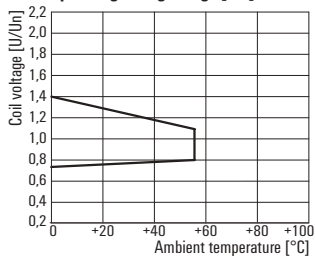

#### Derating curve

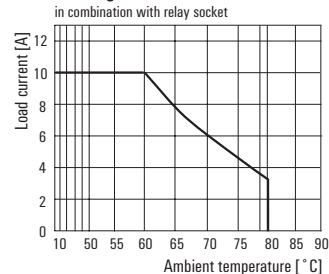

**DRM KIT with screw connection**  
**2 CO contacts**

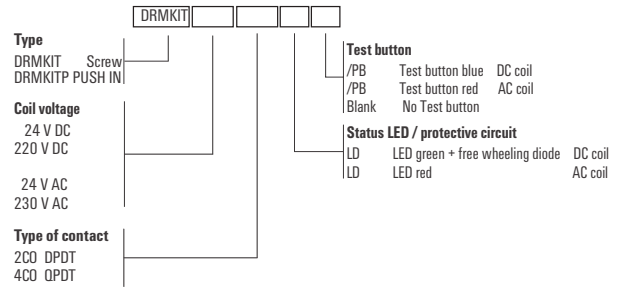

**Ordering data**

Control side	24 V DC 2CO	220 V DC 2CO	24 V AC 2CO	230 V AC 2CO
Rated control voltage	24 V DC	220 V DC	24 V AC	230 V AC
Rated current AC / DC	/ 36.9 mA	/ 5.2 mA	62.4 mA (50 Hz), 52.2 mA (60 Hz) /	6.1 mA (50 Hz), 5.2 mA (60 Hz) /
Power rating	0.9 W	1.2 W	1.0...1.2VA (60HZ)	1.0...1.2VA (60HZ)
Status indicator	Green LED	Green LED	red LED	red LED
Protective circuit	Free-wheeling diode	Free-wheeling diode		

**Ordering data**

	Type	DRMKIT 24VDC 2CO LD/PB	DRMKIT 220VDC 2CO LD/PB	DRMKIT 24VAC 2CO LD/PB	DRMKIT 230VAC 2CO LD/PB
with test button	Order No.	<b>1542460000</b>	<b>1542470000</b>	<b>1542480000</b>	<b>1542490000</b>
without test button	Order No.	<b>1542360000</b>	<b>1542370000</b>	<b>1542380000</b>	<b>1542390000</b>

Note				

**DRM KIT with PUSH IN connection**

**4 CO contact**

- Mounted kit consisting relay, socket and retaining clip
- 100 % function tested
- 100 % check of the dielectric strenght between input - output
- Mechanical status indicator
- Bright status LED (AC coil: red, DC coil: green)
- Optional: test button with coloured control voltage marking (AC coil: red, DC coil: blue)



**Circuit diagram**

**DC-Version**

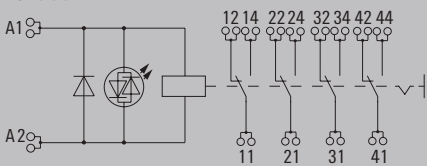

**AC-Version**

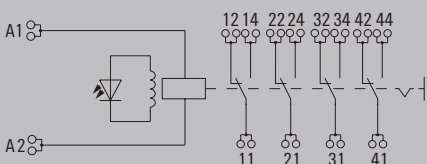

**Technical data**

Load side	
Rated switching voltage / Continuous current	250 V AC / 5 A
Max. switching voltage, AC	250 V
Min. switching power	10 mA @ 12 V, 100 mA @ 5 V
Mechanical service life	20 x 10 <sup>6</sup> switching cycles
Max. switching frequency at rated load	0.1 Hz
General data	
Ambient temperature (operational)	-40 °C...55 °C
Storage temperature	-40 °C...70 °C
Humidity	35...85 % rel. humidity, no condensation
Approvals	CE; UKCA
Insulation coordinates	
Rated voltage	250 V
Impulse withstand voltage	
Dielectric strength for control side - load side	1.8 kV <sub>eff</sub> / 1 min.
Dielectric strength of neighbouring contacts	1 kV <sub>eff</sub> / 1 min
Dielectric strength to mounting rail	
Clearance and creepage distances for control side - load side	≥ 3 mm
Overvoltage category	III
Pollution degree	2
Dimensions	
Depth x width x height	<b>PUSH IN</b> see dimensioned drawing
Note	
Further technical data can be found at <a href="http://eshop.weidmueller.com">eshop.weidmueller.com</a>	

**Applications**

**Electrical endurance**

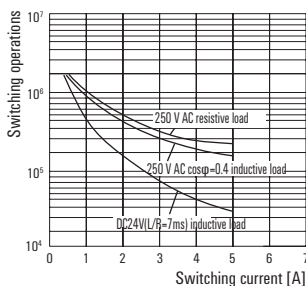

**DC load breaking capacity**

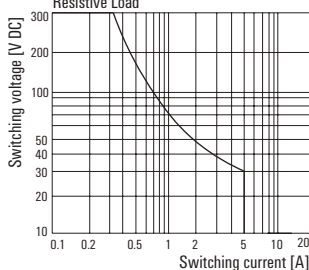

**Dimensioned drawing**

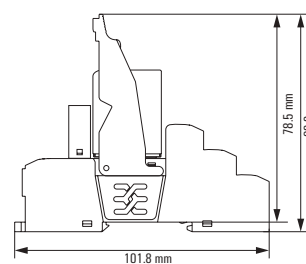

**Operating voltage range [DC]**

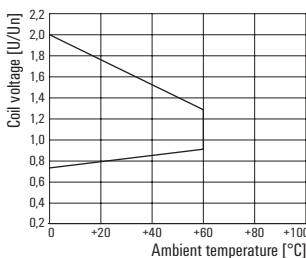

**Operating voltage range [AC]**

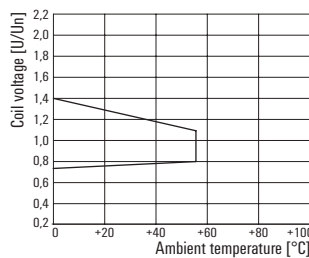

**Derating curve**

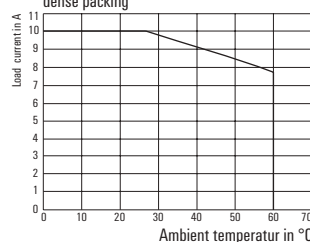

**DRM KIT with PUSH IN connection**  
**4 CO contact**

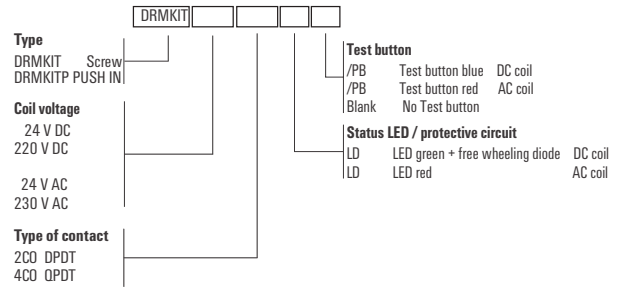

**Ordering data**

Control side	24 V DC	24 V AC	115 V AC	230 V AC
Rated control voltage	24 V DC	24 V AC	115 V AC	230 V AC
Rated current AC / DC	/ 36.9 mA	62.4 mA (50 Hz) /	12.6 mA (50 Hz), 10.8 mA (60 Hz) /	6.1 mA (50 Hz), 5.2 mA (60 Hz) /
Power rating	0.9 W	1.0...1.2VA (60HZ)	1.0...1.2VA (60HZ)	1.0...1.2VA (60HZ)
Status indicator	Green LED	red LED	red LED	red LED
Protective circuit	Free-wheeling diode			

**Ordering data**

		24 V DC	24 V AC	115 V AC	230 V AC
with test button	Type	DRMKITP 24VDC 4CO LD/PB	DRMKITP 24VAC 4CO LD/PB	DRMKITP115VAC 4CO LD/PB	DRMKITP230VAC 4CO LD/PB
	Order No.	<b>2576140000</b>	<b>2576100000</b>	<b>2576020000</b>	<b>2576060000</b>
without test button	Type	DRMKITP 24VDC 4CO LD	DRMKITP 24VAC 4CO LD	DRMKITP 115VAC 4CO LD	DRMKITP 230VAC 4CO LD
	Order No.	<b>2576130000</b>	<b>2576090000</b>	<b>2576010000</b>	<b>2576050000</b>

**Note**

--	--	--	--	--	--

**D-SERIES – relay modules**

**DRM KIT with screw connection**

**4 CO contacts**

- Mounted kit consisting relay, socket and retaining clip
- 100 % function tested
- 100 % check of the dielectric strenght between input - output
- Mechanical status indicator
- Bright status LED (AC coil: red, DC coil: green)
- Optional: test button with coloured control voltage marking (AC coil: red, DC coil: blue)



**B**

**Circuit diagram**

**DC-Version**

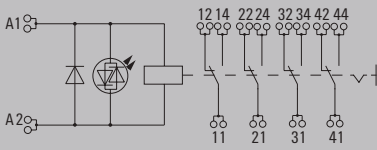

**AC-Version**

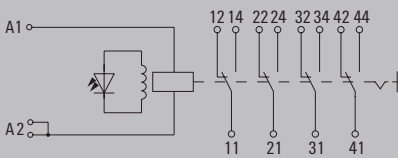

**Technical data**

Load side	
Rated switching voltage / Continuous current	250 V AC / 5 A
Max. switching voltage, AC	250 V
Min. switching power	10 mA @ 12 V, 100 mA @ 5 V
Mechanical service life	20 x 10 <sup>6</sup> switching cycles
Max. switching frequency at rated load	0.1 Hz
General data	
Ambient temperature (operational)	-40 °C...60 °C
Storage temperature	-40 °C...70 °C
Humidity	
Approvals	CE; UKCA
Insulation coordinates	
Rated voltage	250 V
Impulse withstand voltage	4.8 kV (1.2/50 µs)
Dielectric strength for control side - load side	1.8 kV <sub>eff</sub> / 1 min.
Dielectric strength of neighbouring contacts	1 kV <sub>eff</sub> / 1 min
Dielectric strength to mounting rail	
Clearance and creepage distances for control side - load side	≥ 5.5 mm
Overvoltage category	III
Pollution degree	2
Dimensions	
Depth x width x height	see dimensioned drawing
Screw connection	
	see dimensioned drawing
Note	
	Further technical data can be found at <a href="http://eshop.weidmuller.com">eshop.weidmuller.com</a>

**Applications**

**Electrical endurance**

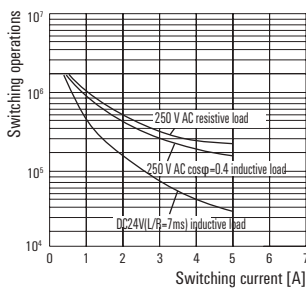

**DC load breaking capacity**

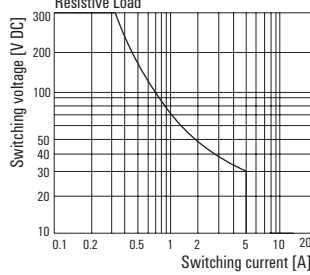

**Dimensioned drawing**

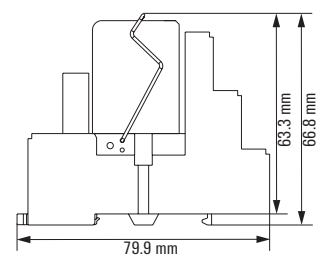

**Operating voltage range [DC]**

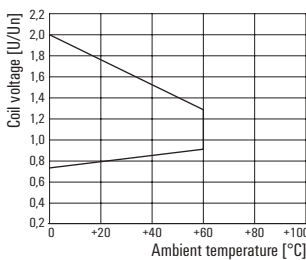

**Operating voltage range [AC]**

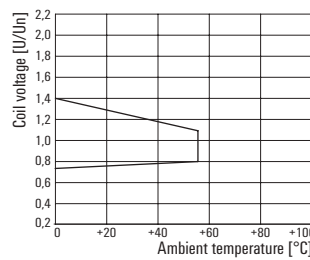

**Derating curve**  
in combination with relay socket

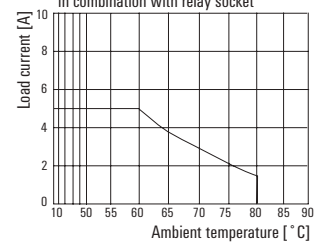

**DRM KIT with screw connection**  
**4 CO contacts**

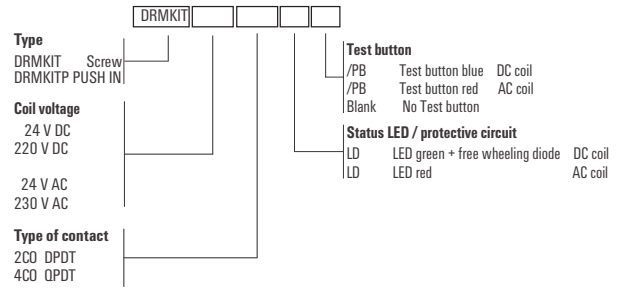

**Ordering data**

Control side	24 V DC 4CO	220 V DC 4CO	24 V AC 4CO	230 V AC 4CO
Rated control voltage	24 V DC	220 V DC	24 V AC	230 V AC
Rated current AC / DC	/ 36.9 mA	/ 5.2 mA	62.4 mA (50 Hz), 52.2 mA (60 Hz) /	6.1 mA (50 Hz), 5.2 mA (60 Hz) /
Power rating	0.9 W	1.2 W	1.0...1.2VA (60HZ)	1.0...1.2VA (60HZ)
Status indicator	Green LED	Green LED	red LED	red LED
Protective circuit	Free-wheeling diode	Free-wheeling diode		

**Ordering data**

		24 V DC 4CO	220 V DC 4CO	24 V AC 4CO	230 V AC 4CO
with test button	Type	DRMKIT 24VDC 4CO LD/PB	DRMKIT 220VDC 4CO LD/PB	DRMKIT 24VAC 4CO LD/PB	DRMKIT 230VAC 4CO LD/PB
	Order No.	<b>1542510000</b>	<b>1542520000</b>	<b>1542530000</b>	<b>1542540000</b>
without test button	Type	DRMKIT 24VDC 4CO LD	DRMKIT 220VDC 4CO LD	DRMKIT 24VAC 4CO LD	DRMKIT 230VAC 4CO LD
	Order No.	<b>1542410000</b>	<b>1542420000</b>	<b>1542430000</b>	<b>1542450000</b>

Note	24 V DC 4CO	220 V DC 4CO	24 V AC 4CO	230 V AC 4CO

**DRM relay**

**2 CO contact, AC/DC coil**

- Compact design combined with high switching capacity
- Wide range of coil voltages
- Optional test button (AC red, DC blue)
- Optional status LED (AC red, DC green)
- Optional free-wheeling diode



**Circuit diagram**

View on pins from below

**AC- and DC coil**

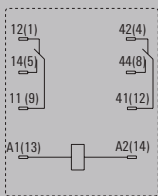

**DC coil LED**

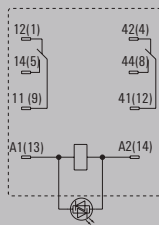

**DC coil LED+diode**

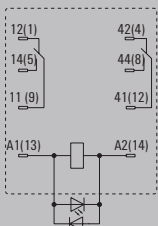

**AC coil LED**

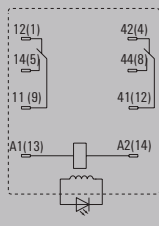

**Technical data**

Load side	
Rated switching voltage / Continuous current	250 V AC / 10 A
Max. switching voltage, AC	
Min. switching power	10 mA @ 12 V, 100 mA @ 5 V
Contact type	2 CO contact (AgNi flash gold-plated)
Mechanical service life	20 x 10 <sup>6</sup> switching cycles
Max. switching frequency at rated load	0.1 Hz
General data	
Ambient temperature (operational)	-40 °C...60 °C
Storage temperature	-40 °C...70 °C
Humidity	35...85 % rel. humidity, no condensation
Approvals	cURus; UKCA
Insulation coordinates	
Rated voltage	250 V
Impulse withstand voltage	6 kV (1.2/50 µs)
Dielectric strength for control side - load side	1.8 kV <sub>eff</sub> / 1 min.
Dielectric strength of neighbouring contacts	1 kV <sub>eff</sub> / 1 min
Dielectric strength to mounting rail	
Clearance and creepage distances for control side - load side	≥ 5.5 mm
Overvoltage category	III
Pollution degree	2

**Dimensions**

Depth x width x height

**Plug-in connection**

see dimensioned drawing

**Note**

Further technical data can be found at [eshop.weidmueller.com](http://eshop.weidmueller.com)

**Applications**

**Electrical endurance**

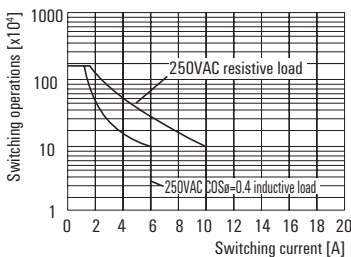

**DC load breaking capacity**

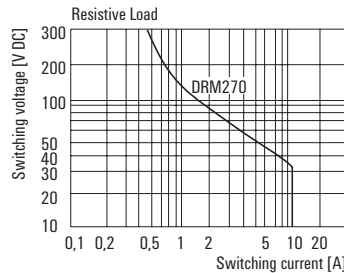

**Dimensioned drawing**

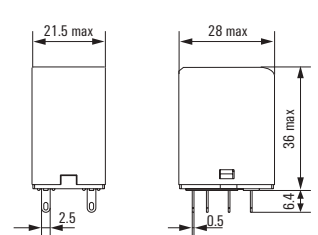

**Operating voltage range [DC]**

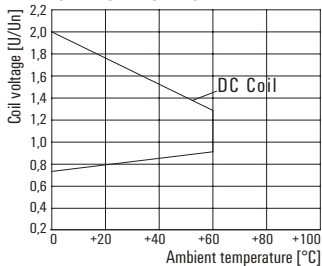

**Operating voltage range [AC]**

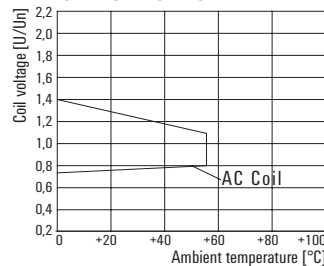

**Derating curve**

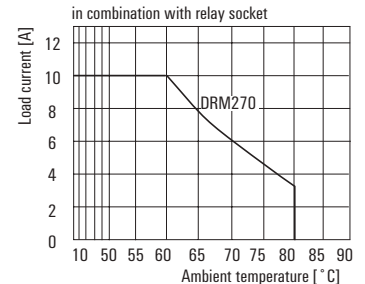

**DRM relay**  
**2 CO contact, AC/DC coil**

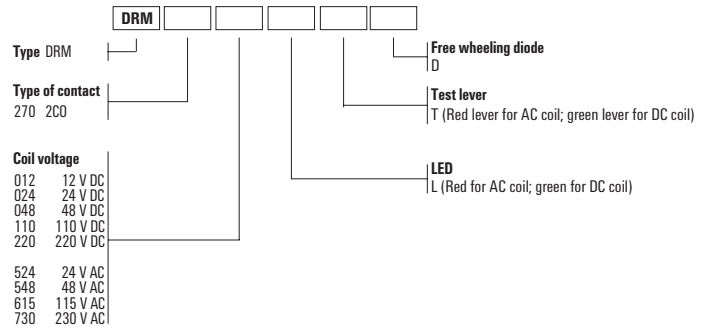

**Ordering data**

Control side	12 V DC 2CO	24 V DC 2CO	48 V DC 2CO	110 V DC 2CO	220 V DC 2CO
Rated control voltage	12 V DC	24 V DC	48 V DC	110 V DC	220 V DC
Rated current AC / DC	/ 75 mA	/ 37.8 mA	/ 18.5 mA	/ 10 mA	/ 5.2 mA
Power rating	0.9 W	0.9 W	0.9 W	1.2 W	1.2 W
Pull-in/drop-out current, typ.					

Ordering data	12 V DC 2CO	24 V DC 2CO	48 V DC 2CO	110 V DC 2CO	220 V DC 2CO
Standard Type	DRM270012	DRM270024	DRM270048	DRM270110	DRM270220
Order No.	<b>7760056050</b>	<b>7760056051</b>	<b>7760056052</b>	<b>7760056053</b>	<b>7760056054</b>
with LED Type	DRM270012L	DRM270024L	DRM270048L	DRM270110L	DRM270220L
Order No.	<b>7760056059</b>	<b>7760056060</b>	<b>7760056061</b>	<b>7760056062</b>	<b>7760056063</b>
with test button + LED Type	DRM270012LT	DRM270024LT	DRM270048LT	DRM270110LT	DRM270220LT
Order No.	<b>7760056068</b>	<b>7760056069</b>	<b>7760056070</b>	<b>7760056071</b>	<b>7760056072</b>
with LED + Free-wheel diode Type		DRM270024LD			
Order No.		<b>7760056077</b>			

Note	12 V DC 2CO	24 V DC 2CO	48 V DC 2CO	110 V DC 2CO	220 V DC 2CO

**Ordering data**

Control side	24 V AC 2CO	48 V AC 2CO	115 V AC 2CO	230 V AC 2CO
Rated control voltage	24 V AC	48 V AC	115 V AC	230 V AC
Rated current AC / DC	62.4 mA (50 Hz), 52.2 mA (60 Hz) /	33.3 mA (50 Hz), 27.8 mA (60 Hz) /	12.6 mA (50 Hz), 10.8 mA (60 Hz) /	6.1 mA (50 Hz), 5.2 mA (60 Hz) /
Power rating	1.0...1.2VA (60HZ)	1.0...1.2VA (60HZ)	1.0...1.2VA (60HZ)	1.0...1.2VA (60HZ)
Pull-in/drop-out current, typ.				

Ordering data	24 V AC 2CO	48 V AC 2CO	115 V AC 2CO	230 V AC 2CO
Standard Type	DRM270524	DRM270548	DRM270615	DRM270730
Order No.	<b>7760056055</b>	<b>7760056056</b>	<b>7760056057</b>	<b>7760056058</b>
with LED Type	DRM270524L	DRM270548L	DRM270615L	DRM270730L
Order No.	<b>7760056064</b>	<b>7760056065</b>	<b>7760056066</b>	<b>7760056067</b>
with test button + LED Type	DRM270524LT	DRM270548LT	DRM270615LT	DRM270730LT
Order No.	<b>7760056073</b>	<b>7760056074</b>	<b>7760056075</b>	<b>7760056076</b>
Type				
Order No.				

Note	24 V AC 2CO	48 V AC 2CO	115 V AC 2CO	230 V AC 2CO

Accessories for DRM relays

- Isolated input and output
- Terminal rail can be unlocked with a screwdriver
- Wide assortment of functional modules

Technical data

<b>Load side</b>	
Rated switching voltage	250 V AC
Max. switching voltage, AC	250 V
Continuous current	12 A
<b>General data</b>	
Ambient temperature (operational)	-40 °C...55 °C
Storage temperature	-40 °C...85 °C
Approvals	CE; cURus; UKCA
<b>Insulation coordinates</b>	
Protection degree	IP20
Clearance and creepage distances for control side - load side	≥ 3 mm
Dielectric strength for control side - load side	4 kV <sub>eff</sub> / 1 min
Dielectric strength of neighbouring contacts	2.5 kV <sub>eff</sub> / 1 Min.
Impulse withstand voltage	
<b>Connection data</b>	
Clamping range (nominal / min. / max.)	1.5 / 0.14 / 1.5 mm <sup>2</sup>
Tightening torque	...
Stripping length, rated connection	10 mm
<b>Note</b>	

Ordering data

	Base, rail-mountable
<b>Note</b>	

Accessories

<b>LED module / protection modules</b>	
Free-wheeling diode 6 - 230 V DC	
LED 6 - 24 V DC green and freewheeling diode	
LED 24 - 60 V DC green and free-wheeling diode	
LED 110 - 230 V DC green and free-wheeling diode	
LED 6 - 24 V UC green	
LED 24 - 60 V UC green	
LED 110 - 230 V UC green	
RC element 110 - 230 V AC; 4.7 kΩ / 10 nF	
RC element 110 - 230 V AC; 100 Ω / 220 nF and LED green	
<b>Retaining clip</b>	
Metal retaining clip	
Plastic retaining bracket with marker holder	
<b>Marking tags</b>	white
<b>Cross-connector</b>	
<b>Screwdriver</b>	
Standard, insulated	
Standard, uninsulated	

**Note**

Socket with PUSH IN connection, 2 CO contact

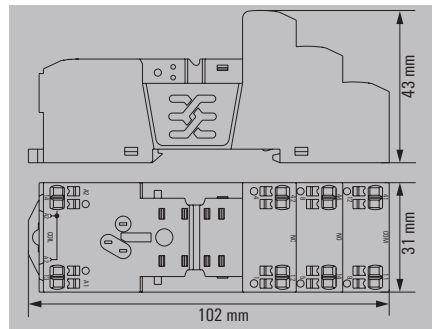

<b>Load side</b>	
Rated switching voltage	250 V AC
Max. switching voltage, AC	250 V
Continuous current	12 A
<b>General data</b>	
Ambient temperature (operational)	-40 °C...55 °C
Storage temperature	-40 °C...85 °C
Approvals	CE; cURus; UKCA
<b>Insulation coordinates</b>	
Protection degree	IP20
Clearance and creepage distances for control side - load side	≥ 3 mm
Dielectric strength for control side - load side	4 kV <sub>eff</sub> / 1 min
Dielectric strength of neighbouring contacts	2.5 kV <sub>eff</sub> / 1 Min.
Impulse withstand voltage	
<b>Connection data</b>	
Clamping range (nominal / min. / max.)	1.5 / 0.14 / 1.5 mm <sup>2</sup>
Tightening torque	...
Stripping length, rated connection	10 mm
<b>Note</b>	

Type	Qty.	Order No.
SCM 2CO P	10	7760056362

Type	Qty.	Order No.
RIM 1 6/230VDC	10	7760056169
RIM 2 6/24VDC	10	7760056015
RIM 2 24/60VDC	10	7760056016
RIM 2 110/230VDC	10	7760056017
RIM 3 6/24VUC	10	7940018457
RIM 3 24/60VUC	10	7760056018
RIM 3 110/230VUC	10	7940018455
RIM 3 110/230VAC	10	7760056014
RIM 3 110/230VAC LED	10	7760056045
DRM/DRL CLIP M	10	7760056108
SCM CLIP P	5	7760056367
ESG 9/26 SCM ECO MC NE WS	80	1520980000
SCM/SDI P CC	10	7760056366
SDIS 0.4X2.5X75	1	9008370000
SDS 0.4X2.5X75	1	9009030000

Further accessories can be found on the article at [eshop.weidmueller.com](https://eshop.weidmueller.com)

Socket module with clamping yoke connection, 2 CO contacts

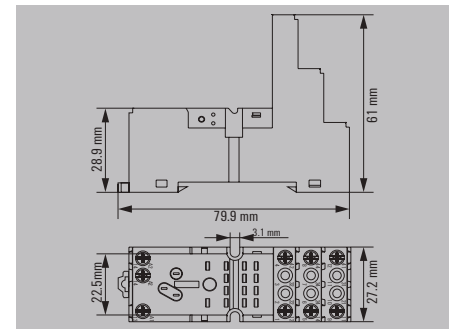

<b>Load side</b>	
Rated switching voltage	250 V AC
Max. switching voltage, AC	250 V
Continuous current	12 A
<b>General data</b>	
Ambient temperature (operational)	-40 °C...70 °C
Storage temperature	-40 °C...70 °C
Approvals	CE; cURus; UKCA
<b>Insulation coordinates</b>	
Protection degree	IP20
Clearance and creepage distances for control side - load side	≥ 5.5 mm
Dielectric strength for control side - load side	4 kV <sub>eff</sub> / 1 min
Dielectric strength of neighbouring contacts	4 kV <sub>eff</sub> / 1 min
Impulse withstand voltage	4.8 kV (1.2/50 μs)
<b>Connection data</b>	
Clamping range (nominal / min. / max.)	/ 0.5 / 2.5 mm <sup>2</sup>
Tightening torque	0.5...0.8 Nm
Stripping length, rated connection	7 mm
<b>Note</b>	

Type	Qty.	Order No.
SCM 2CO ECO	10	7760056263

Type	Qty.	Order No.
RIM 1 6/230VDC	10	7760056169
RIM 2 6/24VDC	10	7760056015
RIM 2 24/60VDC	10	7760056016
RIM 2 110/230VDC	10	7760056017
RIM 3 6/24VUC	10	7940018457
RIM 3 24/60VUC	10	7760056018
RIM 3 110/230VUC	10	7940018455
RIM 3 110/230VAC	10	7760056014
RIM 3 110/230VAC LED	10	7760056045
DRM/DRL CLIP M	10	7760056108
SCM CLIP P	5	7760056367
ESG 9/26 SCM ECO MC NE WS	80	1520980000
SCM QV S	10	1132080000
SDIK PH1 X 80	1	2749890000

Further accessories can be found on the article at [eshop.weidmueller.com](https://eshop.weidmueller.com)

**Socket module with leaf spring connection, 2 CO contacts**

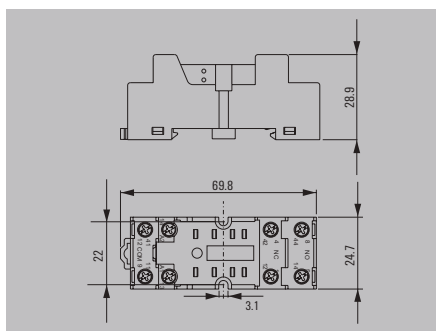

250 V AC
300 V
12 A
-40 °C...70 °C
-40 °C...70 °C
CE; cURus; UKCA
IP10
≥ 4 mm
2 kV <sub>eff</sub> / 1 min
2 kV <sub>eff</sub> / 1 min
4 kV (1.2/50 µs)
/ 0.5 / 2.5 mm <sup>2</sup>
0.5...0.8 Nm
7 mm

Type	Qty.	Order No.
FS 2CO	10	7760056106

Type	Qty.	Order No.
DRM/DRL CLIP M	10	7760056108
SDIK PH1 X 80	1	2749890000

LED and protective modules are not compatible with this base. Further accessories can be found on the article at [eshop.weidmueller.com](http://eshop.weidmueller.com)

**DRM relay**

**4 CO contact, AC/DC coil**

- Compact design combined with high switching capacity
- Wide range of coil voltages
- Optional test button (AC red, DC blue)
- Optional status LED (AC red, DC green)
- Optional free-wheeling diode



**Technical data**

Load side	
Rated switching voltage / Continuous current	250 V AC / 5 A
Max. switching voltage, AC	250 V
Inrush current	10 A / 50 ms
Min. switching power	10 mA @ 12 V, 100 mA @ 5 V
Contact type	4 CO contact (AgNi flash gold-plated)
Mechanical service life	20 x 10 <sup>6</sup> switching cycles
Max. switching frequency at rated load	0.1 Hz
General data	
Ambient temperature (operational)	-40 °C...60 °C
Storage temperature	-40 °C...70 °C
Humidity	35...85 % rel. humidity, no condensation
Approvals	cURus; UKCA
Insulation coordinates	
Rated voltage	250 V
Impulse withstand voltage	6 kV (1.2/50 µs)
Dielectric strength for control side - load side	1.8 kV <sub>eff</sub> / 1 min.
Dielectric strength of neighbouring contacts	1 kV <sub>eff</sub> / 1 min
Dielectric strength to mounting rail	
Clearance and creepage distances for control side - load side	≥ 5.5 mm
Overvoltage category	III
Pollution degree	2

Dimensions	Plug-in connection
Depth x width x height	mm 35.7 / 21 / 27.4

**Note** Further technical data can be found at [eshop.weidmueller.com](http://eshop.weidmueller.com)

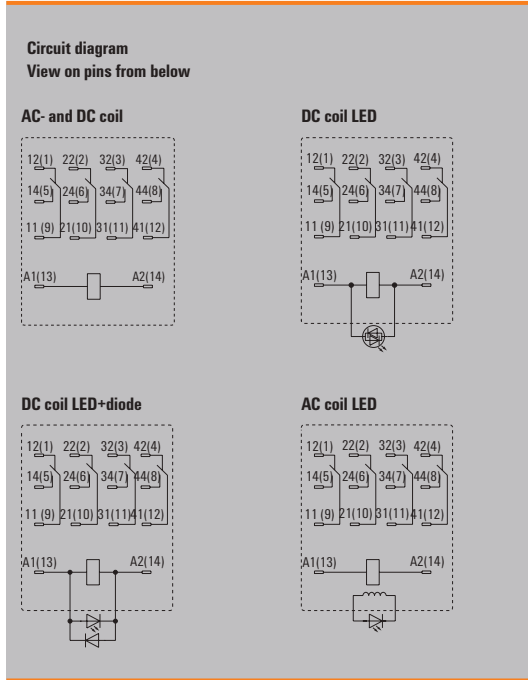

**Applications**

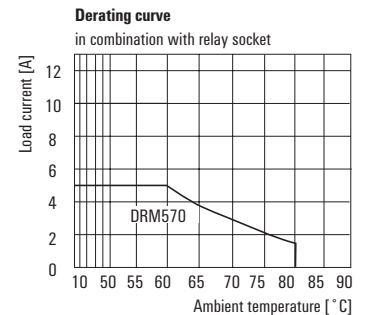
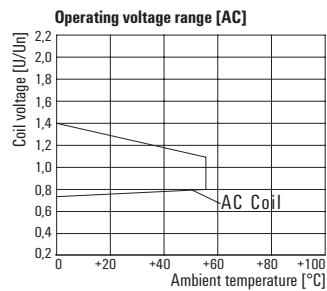
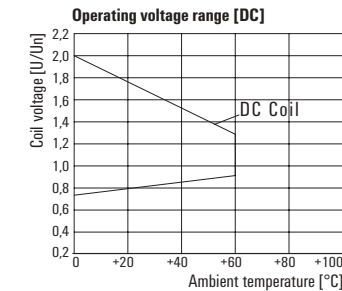
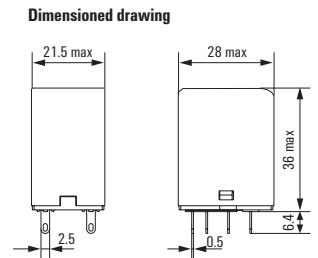
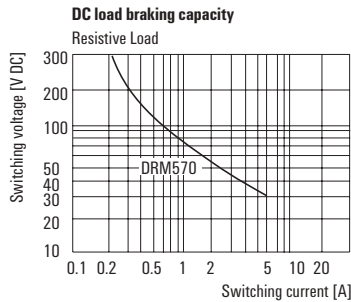
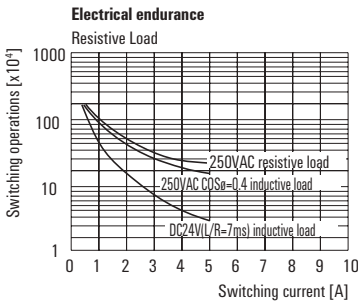

**DRM relay**  
**4 CO contact, AC/DC coil**

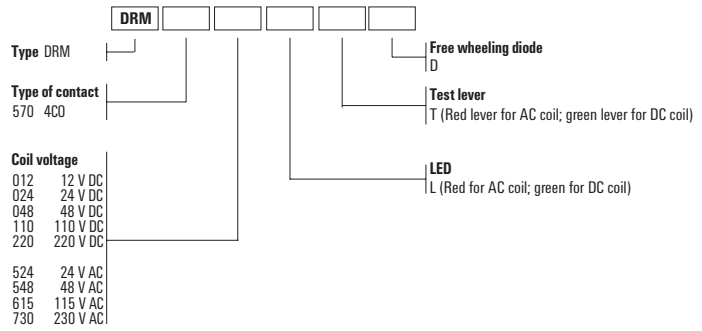

**Ordering data**

Control side	12 V DC 4CO	24 V DC 4CO	48 V DC 4CO	110 V DC 4CO	220 V DC 4CO
Rated control voltage	12 V DC	24 V DC	48 V DC	110 V DC	220 V DC
Rated current AC / DC	/ 75 mA	/ 37.8 mA	/ 18.5 mA	/ 10 mA	/ 5.2 mA
Power rating	0.9 W	0.9 W	0.9 W	1.2 W	1.2 W

**Ordering data**

Standard	Type	Order No.	Standard	Type	Order No.	Standard	Type	Order No.	Standard	Type	Order No.	Standard	Type	Order No.
		DRM570012			DRM570024			DRM570048			DRM570110			DRM570220
with LED		<b>7760056078</b>	with LED		<b>7760056079</b>	with LED		<b>7760056080</b>	with LED		<b>7760056081</b>	with LED		<b>7760056082</b>
		DRM570012L			DRM570024L			DRM570048L			DRM570110L			DRM570220L
with test button + LED		<b>7760056087</b>	with test button + LED		<b>7760056088</b>	with test button + LED		<b>7760056089</b>	with test button + LED		<b>7760056090</b>	with test button + LED		<b>7760056091</b>
		DRM570012LT			DRM570024LT			DRM570048LT			DRM570110LT			DRM570220LT
with LED		<b>7760056096</b>	with LED		<b>7760056097</b>	with LED		<b>7760056098</b>	with LED		<b>7760056099</b>	with LED		<b>7760056100</b>
+ Free-wheel diode			+ Free-wheel diode		<b>7760056105</b>	+ Free-wheel diode			+ Free-wheel diode			+ Free-wheel diode		

**Note**

**Ordering data**

Control side	24 V AC 4CO	48 V AC 4CO	115 V AC 4CO	230 V AC 4CO
Rated control voltage	24 V AC	48 V AC	115 V AC	230 V AC
Rated current AC / DC	62.4 mA (50 Hz), 52.2 mA (60 Hz) /	33.3 mA (50 Hz), 27.8 mA (60 Hz) /	12.6 mA (50 Hz), 10.8 mA (60 Hz) /	6.1 mA (50 Hz), 5.2 mA (60 Hz) /
Power rating	1.0...1.2VA (60HZ)	1.0...1.2VA (60HZ)	1.0...1.2VA (60HZ)	1.0...1.2VA (60HZ)

**Ordering data**

Standard	Type	Order No.	Standard	Type	Order No.	Standard	Type	Order No.	Standard	Type	Order No.
		DRM570524			DRM570548			DRM570615			DRM570730
with LED		<b>7760056083</b>	with LED		<b>7760056084</b>	with LED		<b>7760056085</b>	with LED		<b>7760056086</b>
		DRM570524L			DRM570548L			DRM570615L			DRM570730L
with test button + LED		<b>7760056092</b>	with test button + LED		<b>7760056093</b>	with test button + LED		<b>7760056094</b>	with test button + LED		<b>7760056095</b>
		DRM570524LT			DRM570548LT			DRM570615LT			DRM570730LT
with LED		<b>7760056101</b>	with LED		<b>7760056102</b>	with LED		<b>7760056103</b>	with LED		<b>7760056104</b>
+ Free-wheel diode			+ Free-wheel diode			+ Free-wheel diode			+ Free-wheel diode		

**Note**

Accessories for DRM relays

- Isolated input and output
- Terminal rail can be unlocked with a screwdriver
- Wide assortment of functional modules

Technical data

<b>Load side</b>	
Rated switching voltage	250 V AC
Max. switching voltage, AC	250 V
Continuous current	6 A
<b>General data</b>	
Ambient temperature (operational)	-40 °C...55 °C
Storage temperature	-40 °C...85 °C
Approvals	CE; cURus; UKCA
<b>Insulation coordinates</b>	
Protection degree	IP20
Clearance and creepage distances for control side - load side	≥ 3 mm
Dielectric strength for control side - load side	4 kV <sub>eff</sub> / 1 min
Dielectric strength of neighbouring contacts	2.5 kV <sub>eff</sub> / 1 Min.
Impulse withstand voltage	
<b>Connection data</b>	
Clamping range (nominal / min. / max.)	1.5 / 0.14 / 1.5 mm <sup>2</sup>
Tightening torque	...
Stripping length, rated connection	10 mm
<b>Note</b>	

Ordering data

	Base, rail-mountable
<b>Note</b>	

Accessories

<b>LED module / protection modules</b>	
Free-wheeling diode 6 - 230 V DC	
LED 6 - 24 V DC green and freewheeling diode	
LED 24 - 60 V DC green and free-wheeling diode	
LED 110 - 230 V DC green and free-wheeling diode	
LED 6 - 24 V UC green	
LED 24 - 60 V UC green	
LED 110 - 230 V UC green	
RC element 110 - 230 V AC; 4.7 kΩ / 10 nF	
RC element 110 - 230 V AC; 100 Ω / 220 nF and LED green	
<b>Retaining clip</b>	
Metal retaining clip	
Plastic retaining bracket with marker holder	
<b>Marking tags</b>	white
<b>Cross-connector</b>	
<b>Screwdriver</b>	
Standard, insulated	
Standard, uninsulated	
Standard, uninsulated	

**Note**

Socket with PUSH IN connection, 4 CO contact

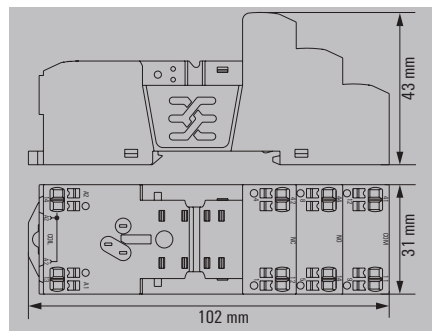

<b>Load side</b>	
Rated switching voltage	250 V AC
Max. switching voltage, AC	250 V
Continuous current	6 A
<b>General data</b>	
Ambient temperature (operational)	-40 °C...55 °C
Storage temperature	-40 °C...85 °C
Approvals	CE; cURus; UKCA
<b>Insulation coordinates</b>	
Protection degree	IP20
Clearance and creepage distances for control side - load side	≥ 3 mm
Dielectric strength for control side - load side	4 kV <sub>eff</sub> / 1 min
Dielectric strength of neighbouring contacts	2.5 kV <sub>eff</sub> / 1 Min.
Impulse withstand voltage	
<b>Connection data</b>	
Clamping range (nominal / min. / max.)	1.5 / 0.14 / 1.5 mm <sup>2</sup>
Tightening torque	...
Stripping length, rated connection	10 mm
<b>Note</b>	

Type	Qty.	Order No.
SCM 4CO P	10	7760056363

Type	Qty.	Order No.
RIM 1 6/230VDC	10	7760056169
RIM 2 6/24VDC	10	7760056015
RIM 2 24/60VDC	10	7760056016
RIM 2 110/230VDC	10	7760056017
RIM 3 6/24VUC	10	7940018457
RIM 3 24/60VUC	10	7760056018
RIM 3 110/230VUC	10	7940018455
RIM 3 110/230VAC	10	7760056014
RIM 3 110/230VAC LED	10	7760056045
DRM/DRL CLIP M	10	7760056108
SCM CLIP P	5	7760056367
ESG 9/26 SCM ECO MC NE WS	80	1520980000
SCM/SDI P CC	10	7760056366
SDIS 0.4X2.5X75	1	9008370000
SDS 0.4X2.5X75	1	9009030000

Further accessories can be found on the article at [eshop.weidmueller.com](http://eshop.weidmueller.com)

Socket module with clamping yoke connection, 4 CO contacts

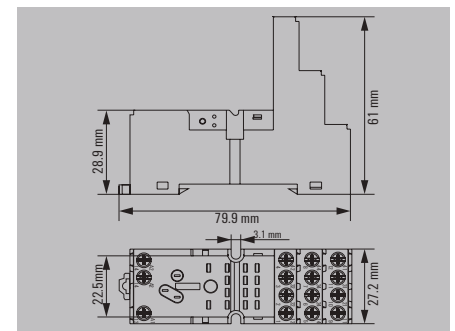

<b>Load side</b>	
Rated switching voltage	250 V AC
Max. switching voltage, AC	250 V
Continuous current	6 A
<b>General data</b>	
Ambient temperature (operational)	-40 °C...70 °C
Storage temperature	-40 °C...70 °C
Approvals	CE; cURus; UKCA
<b>Insulation coordinates</b>	
Protection degree	IP20
Clearance and creepage distances for control side - load side	≥ 5.5 mm
Dielectric strength for control side - load side	4 kV <sub>eff</sub> / 1 min
Dielectric strength of neighbouring contacts	4 kV <sub>eff</sub> / 1 min
Impulse withstand voltage	4.8 kV (1.2/50 μs)
<b>Connection data</b>	
Clamping range (nominal / min. / max.)	/ 0.5 / 2.5 mm <sup>2</sup>
Tightening torque	0.5...0.8 Nm
Stripping length, rated connection	7 mm
<b>Note</b>	

Type	Qty.	Order No.
SCM 4CO ECO	10	7760056264

Type	Qty.	Order No.
RIM 1 6/230VDC	10	7760056169
RIM 2 6/24VDC	10	7760056015
RIM 2 24/60VDC	10	7760056016
RIM 2 110/230VDC	10	7760056017
RIM 3 6/24VUC	10	7940018457
RIM 3 24/60VUC	10	7760056018
RIM 3 110/230VUC	10	7940018455
RIM 3 110/230VAC	10	7760056014
RIM 3 110/230VAC LED	10	7760056045
DRM/DRL CLIP M	10	7760056108
SCM CLIP P	5	7760056367
ESG 9/26 SCM ECO MC NE WS	80	1520980000
SCM QV S	10	1132080000
SDIK PH1 X 80	1	2749890000
SDIK SLIM PH1 X 80	1	2749650000
SDK PH1 X 80	1	2749410000

Further accessories can be found on the article at [eshop.weidmueller.com](http://eshop.weidmueller.com)

### Socket module with leaf spring connection, 4 CO contacts

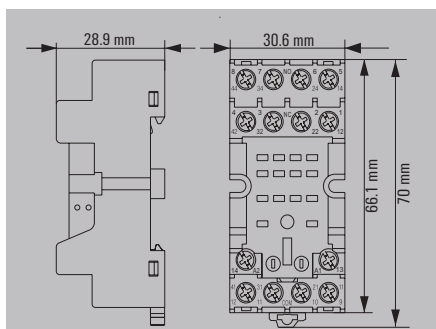

250 V AC

300 V

10 A

-40 °C...70 °C

-40 °C...70 °C

CE; cURus; UKCA

IP10

≥ 4 mm

2 kV<sub>eff</sub> / 1 min2 kV<sub>eff</sub> / 1 min

4 kV (1.2/50 µs)

/ 0.5 / 2.5 mm<sup>2</sup>

0.5...0.8 Nm

7 mm

Type	Qty.	Order No.
FS 4CO	10	7760056107

Type	Qty.	Order No.
RIM 1 6/230VDC	10	7760056169
RIM 2 6/24VDC	10	7760056015
RIM 2 24/60VDC	10	7760056016
RIM 2 110/230VDC	10	7760056017
RIM 3 6/24VUC	10	7940018457
RIM 3 24/60VUC	10	7760056018
RIM 3 110/230VUC	10	7940018455
RIM 3 110/230VAC	10	7760056014

DRM/DRL CLIP M	10	7760056108
----------------	----	------------

SDIK PH1 X 80	1	2749890000
SDIK SLIM PH1 X 80	1	2749650000
SDK PH1 X 80	1	2749410000

Further accessories can be found on the article at [eshop.weidmueller.com](http://eshop.weidmueller.com)

**DRR power relay**

**2 CO contact, AC/DC coil**

- 2,500 VA switching capacity
- 8-pole relay



**Circuit diagram**  
View on pins from below

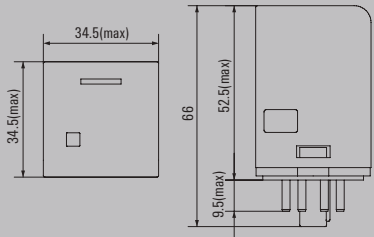
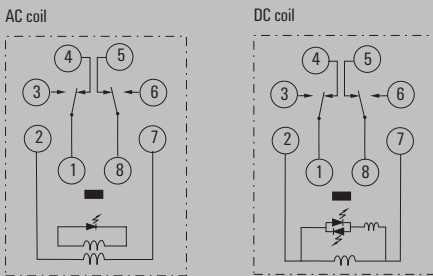

**Technical data**

Load side	
Rated switching voltage / Continuous current	250 V AC / 10 A
Max. switching voltage, AC	250 V
Inrush current	50 A / 50 ms
Min. switching power	10 mA @ 12 V
Contact type	2 CO contact (AgSnO)
Mechanical service life	10 x 10 <sup>6</sup> switching cycles
Max. switching frequency at rated load	0.1 Hz
General data	
Ambient temperature (operational)	-25 °C...55 °C
Storage temperature	-25 °C...55 °C
Humidity	5...85 % rel. humidity, no condensation
Approvals	cURus
Insulation coordinates	
Rated voltage	250 V
Impulse withstand voltage	4 kV (1.2/50 µs)
Dielectric strength for control side - load side	2.5 kV <sub>eff</sub> / 1 Min.
Dielectric strength of neighbouring contacts	2.5 kV <sub>eff</sub> / 1 Min.
Dielectric strength to mounting rail	
Clearance and creepage distances for control side - load side	≥ 4 mm
Overvoltage category	III
Pollution degree	3

Dimensions	Plug-in connection
Depth x width x height	mm 66 / 34.5 / 34.5

**Note** Further technical data can be found at [eshop.weidmueller.com](http://eshop.weidmueller.com)

**Applications**

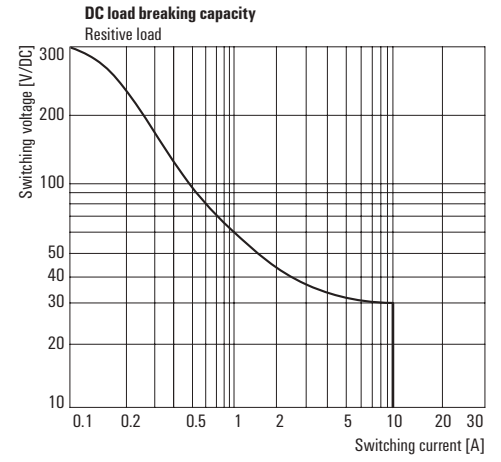
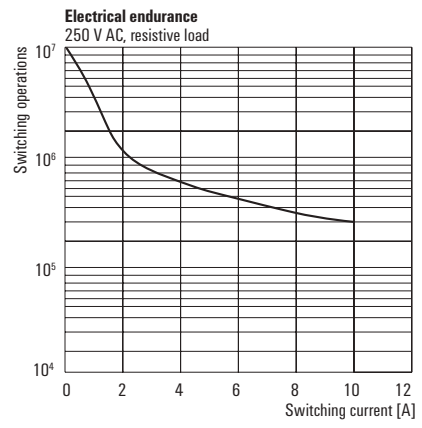
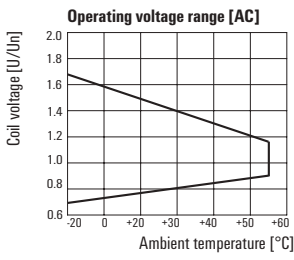
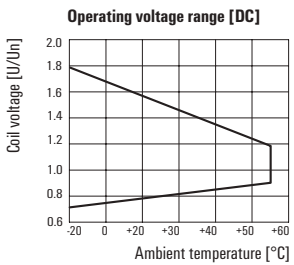

**DRR power relay**  
**2 CO contact, AC/DC coil**

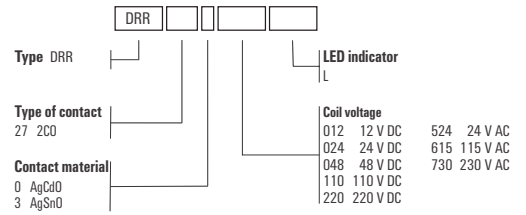

**Ordering data**

Control side	12 V DC 2CO	24 V DC 2CO	48 V DC 2CO	110 V DC 2CO	220 V DC 2CO
Rated control voltage	12 V DC	24 V DC	48 V DC	110 V DC	220 V DC
Rated current AC / DC	/ 125 mA	/ 55.8 mA	/ 29.2 mA	/ 15 mA	/ 7.6 mA
Power rating	1.5 W	1.5 W	1.5 W	1.5 W	1.5 W
Status indicator	Green LED	Green LED	Green LED	Green LED	Green LED

Ordering data					
Type	DRR273012L	DRR273024L	DRR273048L	DRR273110L	DRR273220L
Order No.	<b>2765010000</b>	<b>2765020000</b>	<b>2765030000</b>	<b>2765040000</b>	<b>2765050000</b>
Type					
Order No.					
Note					

**Ordering data**

Control side	24 V AC 2CO	115 V AC 2CO	230 V AC 2CO
Rated control voltage	24 V AC	115 V AC	230 V AC
Rated current AC / DC	130 mA (50 Hz), 116 mA (60 Hz) /	29.8 mA (50 Hz), 25.4 mA (60 Hz) /	14.9 mA (50 Hz), 12.7 mA (60 Hz) /
Power rating	2.7 VA	2.7 VA	2.7 VA
Status indicator	red LED	red LED	red LED

Ordering data			
Type	DRR273524L	DRR273615L	DRR273730L
Order No.	<b>2765310000</b>	<b>2765320000</b>	<b>2765330000</b>
Type			
Order No.			
Note			

**DRR power relay**

**3 CO contact, AC/DC coil**

- 2,500 VA switching capacity
- 11-pole relay



**Technical data**

Load side	
Rated switching voltage / Continuous current	250 V AC / 10 A
Max. switching voltage, AC	250 V
Inrush current	50 A / 50 ms
Min. switching power	10 mA @ 12 V
Contact type	3 CO contact (AgSnO)
Mechanical service life	10 x 10 <sup>6</sup> switching cycles
Max. switching frequency at rated load	0.1 Hz
General data	
Ambient temperature (operational)	-25 °C...55 °C
Storage temperature	-25 °C...55 °C
Humidity	5...85 % rel. humidity, no condensation
Approvals	cURus
Insulation coordinates	
Rated voltage	250 V
Impulse withstand voltage	4 kV (1.2/50 µs)
Dielectric strength for control side - load side	2.5 kV <sub>eff</sub> / 1 Min.
Dielectric strength of neighbouring contacts	2.5 kV <sub>eff</sub> / 1 Min.
Dielectric strength to mounting rail	
Clearance and creepage distances for control side - load side	≥ 3 mm
Overvoltage category	III
Pollution degree	3

**Circuit diagram**  
View on pins from below

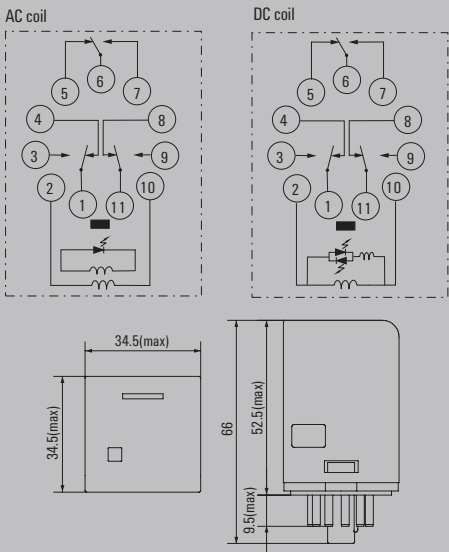

Dimensions	Plug-in connection
Depth x width x height	mm 66 / 34.5 / 34.5

**Note** Further technical data can be found at [eshop.weidmueller.com](http://eshop.weidmueller.com)

**Applications**

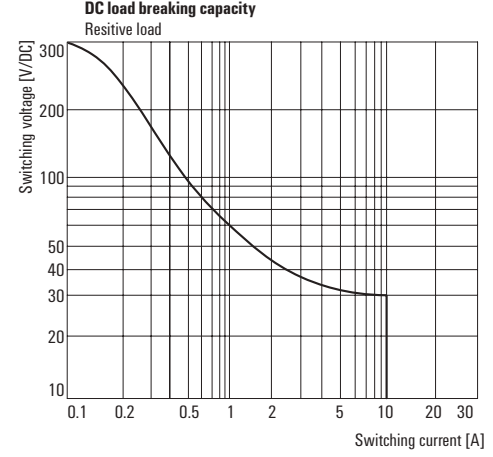
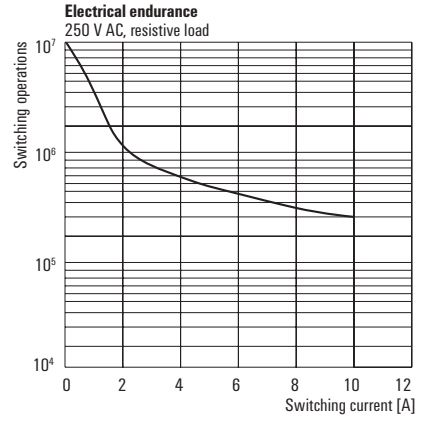
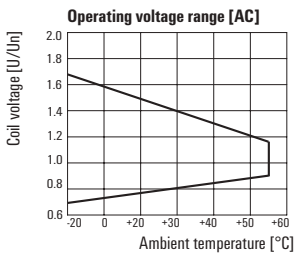
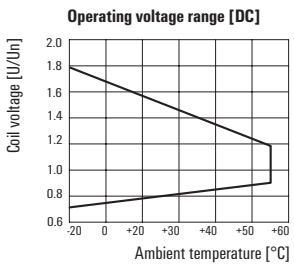

**DRR power relay**  
**3 CO contact, AC/DC coil**

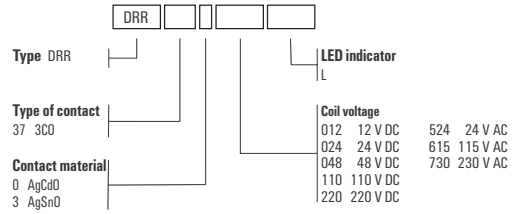

**Ordering data**

Control side	12 V DC 3CO	24 V DC 3CO	48 V DC 3CO	110 V DC 3CO	220 V DC 3CO
Rated control voltage	12 V DC	24 V DC	48 V DC	110 V DC	220 V DC
Rated current AC / DC	/ 125 mA	/ 55.8 mA	/ 29.2 mA	/ 15 mA	/ 7.6 mA
Power rating	1.5 W	1.5 W	1.5 W	1.5 W	1.5 W
Status indicator	Green LED	Green LED	Green LED	Green LED	Green LED

Ordering data					
Type	DRR373012L	DRR373024L	DRR373048L	DRR373110L	DRR373220L
Order No.	<b>2765060000</b>	<b>2765070000</b>	<b>2765080000</b>	<b>2765090000</b>	<b>2765200000</b>
Type					
Order No.					
Note					

**Ordering data**

Control side	24 V AC 3CO	115 V AC 3CO	230 V AC 3CO
Rated control voltage	24 V AC	115 V AC	230 V AC
Rated current AC / DC	130 mA (50 Hz), 116 mA (60 Hz) /	29.8 mA (50 Hz), 25.4 mA (60 Hz) /	14.9 mA (50 Hz), 12.7 mA (60 Hz) /
Power rating	2.7 VA	2.7 VA	2.7 VA
Status indicator	red LED	red LED	red LED

Ordering data			
Type	DRR373524L	DRR373615L	DRR373730L
Order No.	<b>2765340000</b>	<b>2765350000</b>	<b>2765360000</b>
Type			
Order No.			
Note			

Accessories for DRR relays

Socket module with leaf spring connection, 2 CO contacts

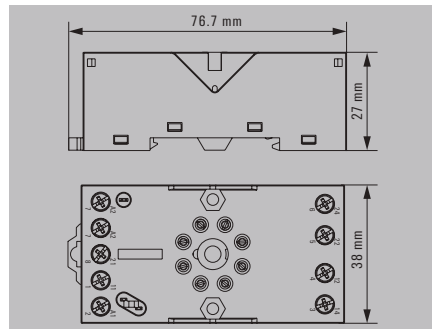

Technical data

<b>Load side</b>	
Rated switching voltage	250 V AC
Max. switching voltage, AC	300 V
Continuous current	12 A
<b>General data</b>	
Ambient temperature (operational)	-40 °C...65 °C
Storage temperature	-40 °C...85 °C
Approvals	CE; cURus; UKCA
<b>Insulation coordinates</b>	
Protection degree	IP20
Clearance and creepage distances for control side - load side	≥ 4 mm
Dielectric strength for control side - load side	2.5 kV <sub>eff</sub> / 1 Min.
Dielectric strength of neighbouring contacts	2.21 kV <sub>eff</sub> / 1 min
Impulse withstand voltage	4.8 kV (1.2/50 µs)
<b>Connection data</b>	
Clamping range (nominal / min. / max.)	/ 0.5 / 2.5 mm <sup>2</sup>
Tightening torque	0.5...1 Nm
Stripping length, rated connection	7 mm
<b>Note</b>	

Ordering data

	Base, rail-mountable
<b>Note</b>	

Accessories

<b>LED module / protection modules</b>	
	RC element 6 - 230 V AC
	Free-wheeling diode 6 - 230 V DC
<b>Retaining clip</b>	
	Metal retaining clip
<b>Screwdriver</b>	
	Standard, uninsulated
	Standard, insulated
	Standard, uninsulated

**Note**

Socket module with leaf spring connection, 3 CO contacts

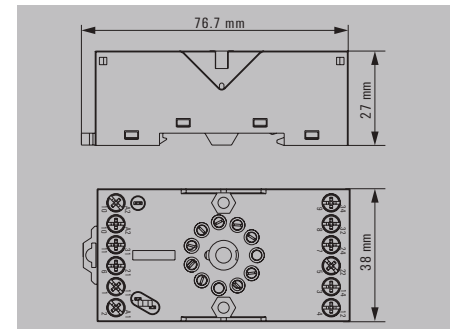

<b>Load side</b>	
Rated switching voltage	250 V AC
Max. switching voltage, AC	300 V
Continuous current	12 A
<b>General data</b>	
Ambient temperature (operational)	-40 °C...65 °C
Storage temperature	-40 °C...85 °C
Approvals	CE; cURus; UKCA
<b>Insulation coordinates</b>	
Protection degree	IP20
Clearance and creepage distances for control side - load side	≥ 4 mm
Dielectric strength for control side - load side	2.5 kV <sub>eff</sub> / 1 Min.
Dielectric strength of neighbouring contacts	2.21 kV <sub>eff</sub> / 1 min
Impulse withstand voltage	4.8 kV (1.2/50 µs)
<b>Connection data</b>	
Clamping range (nominal / min. / max.)	/ 0.5 / 2.5 mm <sup>2</sup>
Tightening torque	0.5...1 Nm
Stripping length, rated connection	7 mm
<b>Note</b>	

<b>Type</b>	<b>Qty.</b>	<b>Order No.</b>
SRD ECO 2CO	10	1132810000
<b>Note</b>		

<b>Type</b>	<b>Qty.</b>	<b>Order No.</b>
RIM 5 6/230VAC	10	1174670000
RIM 5 6/230VDC	10	1174650000
DRR CLIP M	10	1134160000
SDIK SLIM PH1 X 80	1	2749650000
SDIK PH1 X 80	1	2749890000
SDK PH1 X 80	1	2749410000

Further accessories can be found on the article at [eshop.weidmueller.com](http://eshop.weidmueller.com)

<b>Type</b>	<b>Qty.</b>	<b>Order No.</b>
SRD ECO 3CO	10	1132820000
<b>Note</b>		

<b>Type</b>	<b>Qty.</b>	<b>Order No.</b>
RIM 5 6/230VAC	10	1174670000
RIM 5 6/230VDC	10	1174650000
DRR CLIP M	10	1134160000
SDIK SLIM PH1 X 80	1	2749650000
SDIK PH1 X 80	1	2749890000
SDK PH1 X 80	1	2749410000

Further accessories can be found on the article at [eshop.weidmueller.com](http://eshop.weidmueller.com)



**DRL power relay**

**1 CO contact, AC/DC coil**

- High wear resistance in case of AC loads
- High dielectric strength: 2,000 V



**Circuit diagram**  
View on pins from below

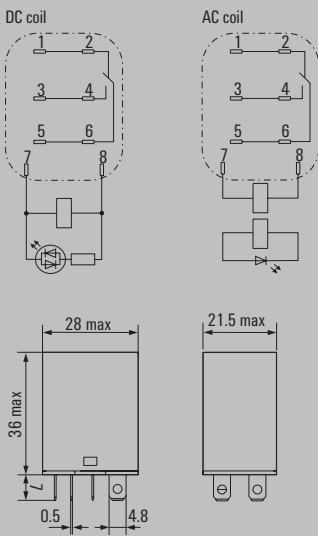

**Technical data**

Load side	
Rated switching voltage / Continuous current	250 V AC / 16 A
Max. switching voltage, AC	250 V
Inrush current	80 A / 50 ms
Min. switching power	10 mA @ 12 V
Contact type	1 CO contact (AgSnO)
Mechanical service life	10 x 10 <sup>6</sup> switching cycles
Max. switching frequency at rated load	0.1 Hz
General data	
Ambient temperature (operational)	-25 °C...55 °C
Storage temperature	-25 °C...55 °C
Humidity	35 % to 85 % relative humidity level
Approvals	cURus
Insulation coordinates	
Rated voltage	250 V
Impulse withstand voltage	5 kV (1.2/50 µs)
Dielectric strength for control side - load side	2.5 kV <sub>eff</sub> / 1 min
Dielectric strength of neighbouring contacts	2 kV <sub>eff</sub> / 1 min
Dielectric strength to mounting rail	
Clearance and creepage distances for control side - load side	≥ 4 mm
Overvoltage category	III
Pollution degree	3

Dimensions	Flat blade connections (4.8 mm x 0.5 mm)
Depth x width x height	mm 36 / 21.5 / 28

**Note** Further technical data can be found at [eshop.weidmueller.com](http://eshop.weidmueller.com)

**Applications**

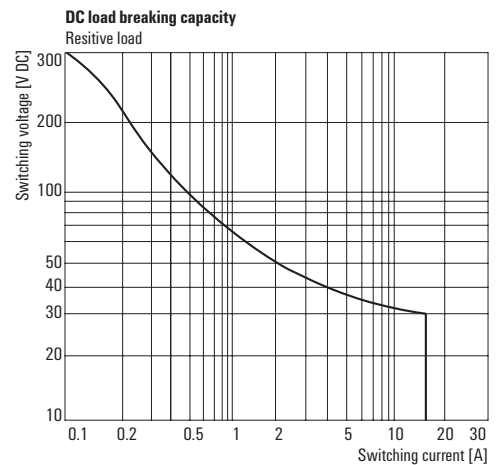
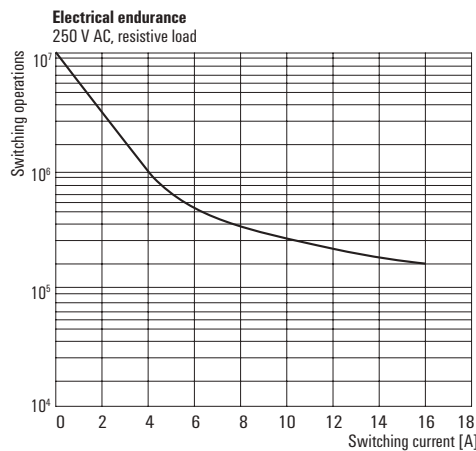
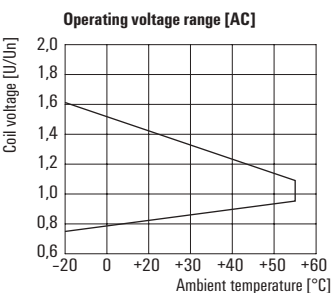
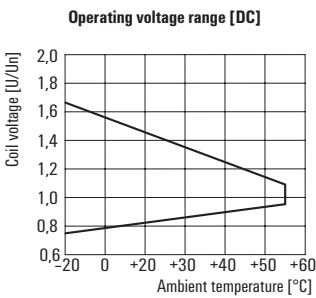

**DRL power relay**  
**1 CO contact, AC/DC coil**

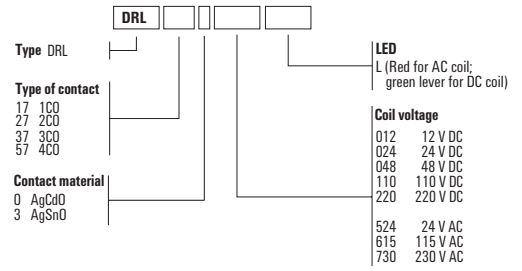

**Ordering data**

	12 V DC	24 V DC	48 V DC	110 V DC	220 V DC
<b>Control side</b>					
Rated control voltage	12 V DC	24 V DC	48 V DC	110 V DC	220 V DC
Rated current AC / DC	/ 75 mA	/ 36.9 mA	/ 18.5 mA	/ 10 mA	/ 5.2 mA
Power rating	0.9 W	0.9 W	0.9 W	0.9 W	0.9 W
Status indicator	Green LED	Green LED	Green LED	Green LED	Green LED

Ordering data						
1 CO contact	Type	DRL173012L	DRL173024L	DRL173048L	DRL173110L	DRL173220L
	Order No.	<b>2765100000</b>	<b>2765110000</b>	<b>2765120000</b>	<b>2765130000</b>	<b>2765140000</b>
	Type					
	Order No.					
<b>Note</b>						

**Ordering data**

	24 V AC	115 V AC	230 V AC
<b>Control side</b>			
Rated control voltage	24 V AC	115 V AC	230 V AC
Rated current AC / DC	54 mA /	12,9 mA /	6.8 mA /
Power rating	1.2 VA	1.2 VA	1.2 VA
Status indicator	red LED	red LED	red LED

Ordering data				
1 CO contact	Type	DRL173524L	DRL173615L	DRL173730L
	Order No.	<b>2765370000</b>	<b>2765380000</b>	<b>2765390000</b>
	Type			
	Order No.			
<b>Note</b>				

**DRL power relay**

**2 CO contact, AC/DC coil**

- High wear resistance in case of AC loads
- High dielectric strength: 2,000 V



**Circuit diagram**  
View on pins from below

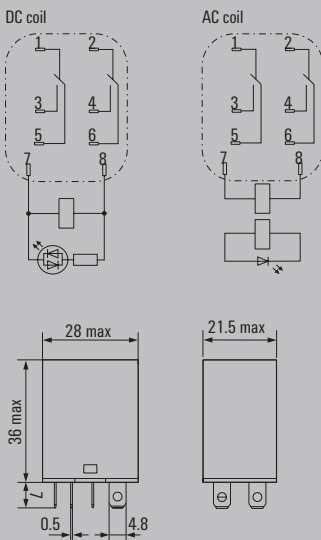

**Technical data**

Load side	
Rated switching voltage / Continuous current	250 V AC / 10 A
Max. switching voltage, AC	250 V
Inrush current	50 A / 50 ms
Min. switching power	10 mA @ 12 V
Contact type	2 CO contact (AgSnO)
Mechanical service life	10 x 10 <sup>6</sup> switching cycles
Max. switching frequency at rated load	0.1 Hz
General data	
Ambient temperature (operational)	-25 °C...55 °C
Storage temperature	-25 °C...55 °C
Humidity	35 % to 85 % relative humidity level
Approvals	cURus
Insulation coordinates	
Rated voltage	250 V
Impulse withstand voltage	5 kV (1.2/50 µs)
Dielectric strength for control side - load side	2.5 kV <sub>eff</sub> / 1 min
Dielectric strength of neighbouring contacts	1.2 kV <sub>eff</sub> / 1 min.
Dielectric strength to mounting rail	
Clearance and creepage distances for control side - load side	≥ 4 mm
Overvoltage category	III
Pollution degree	3

Dimensions	Flat blade connections (4.8 mm x 0.5 mm)
Depth x width x height	mm 36 / 21.5 / 28

**Note** Further technical data can be found at [eshop.weidmueller.com](http://eshop.weidmueller.com)

**Applications**

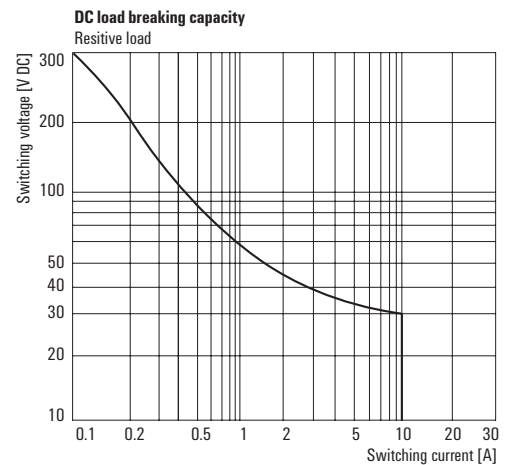
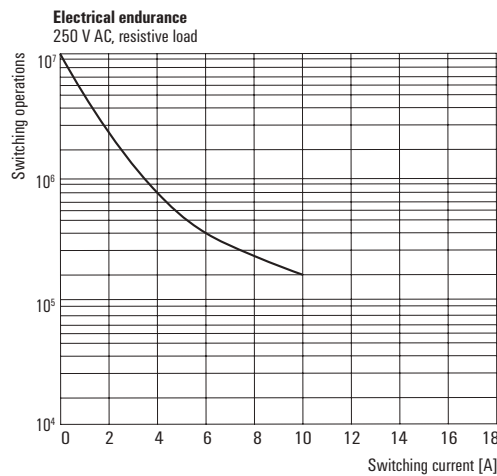
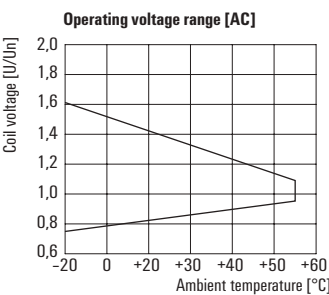
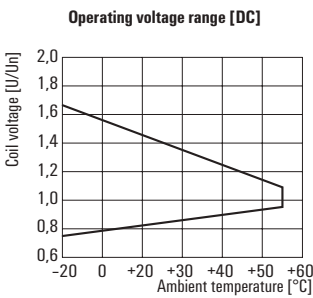

**DRL power relay**  
**2 CO contact, AC/DC coil**

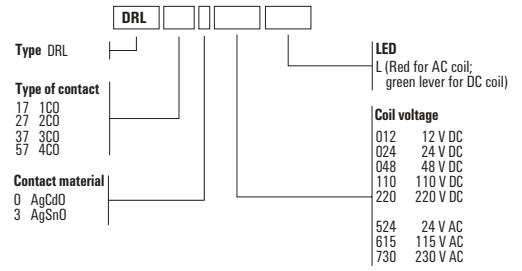

**Ordering data**

	12 V DC	24 V DC	48 V DC	110 V DC	220 V DC
<b>Control side</b>					
Rated control voltage	12 V DC	24 V DC	48 V DC	110 V DC	220 V DC
Rated current AC / DC	/ 75 mA	/ 36.9 mA	/ 18.5 mA	/ 10 mA	/ 5.2 mA
Power rating	0.9 W	0.9 W	0.9 W	0.9 W	0.9 W
Status indicator	Green LED	Green LED	Green LED	Green LED	Green LED

Ordering data						
2 CO contacts	Type	DRL273012L	DRL273024L	DRL273048L	DRL273110L	DRL273220L
	Order No.	<b>2765150000</b>	<b>2765160000</b>	<b>2765170000</b>	<b>2765180000</b>	<b>2765190000</b>
	Type					
	Order No.					
<b>Note</b>						

**Ordering data**

	24 V AC	115 V AC	230 V AC
<b>Control side</b>			
Rated control voltage	24 V AC	115 V AC	230 V AC
Rated current AC / DC	54 mA /	12,9 mA /	6.8 mA /
Power rating	1.2 VA	1.2 VA	1.2 VA
Status indicator	red LED	red LED	red LED

Ordering data				
2 CO contacts	Type	DRL273524L	DRL273615L	DRL273730L
	Order No.	<b>2765400000</b>	<b>2765410000</b>	<b>2765420000</b>
	Type			
	Order No.			
<b>Note</b>				

**DRL power relay**

**3 CO contact, AC/DC coil**

- High wear resistance in case of AC loads
- High dielectric strength: 2,000 V



**Circuit diagram**  
View on pins from below

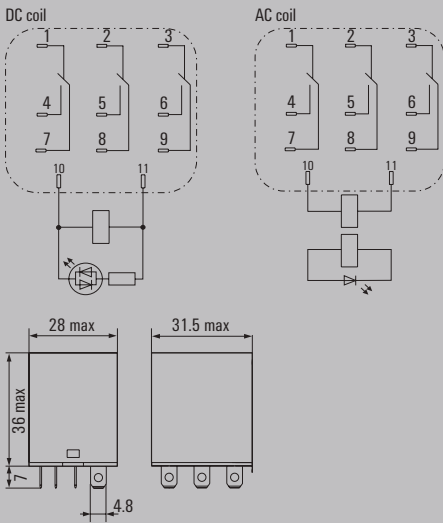

**Technical data**

Load side	
Rated switching voltage / Continuous current	250 V AC / 10 A
Max. switching voltage, AC	250 V
Inrush current	50 A / 50 ms
Min. switching power	10 mA @ 12 V
Contact type	3 CO contact (AgSnO)
Mechanical service life	10 x 10 <sup>6</sup> switching cycles
Max. switching frequency at rated load	0.1 Hz
General data	
Ambient temperature (operational)	-25 °C...55 °C
Storage temperature	-25 °C...55 °C
Humidity	35 % to 85 % relative humidity level
Approvals	cURus
Insulation coordinates	
Rated voltage	250 V
Impulse withstand voltage	5 kV (1.2/50 µs)
Dielectric strength for control side - load side	2.5 kV <sub>eff</sub> / 1 min
Dielectric strength of neighbouring contacts	2 kV <sub>eff</sub> / 1 min
Dielectric strength to mounting rail	
Clearance and creepage distances for control side - load side	≥ 4 mm
Overvoltage category	III
Pollution degree	3

Dimensions	Flat blade connections (4.8 mm x 0.5 mm)
Depth x width x height	mm 36 / 31.5 / 28

**Note** Further technical data can be found at [eshop.weidmueller.com](http://eshop.weidmueller.com)

**Applications**

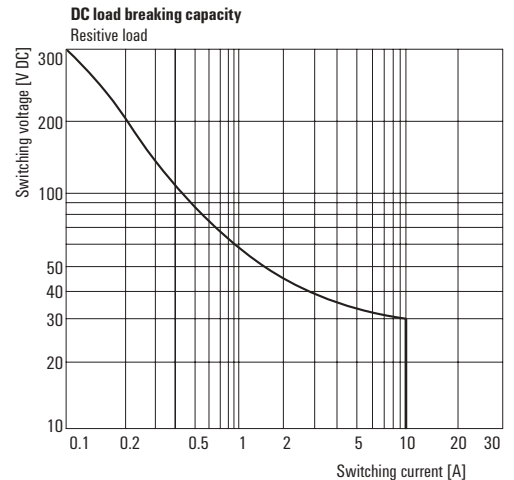
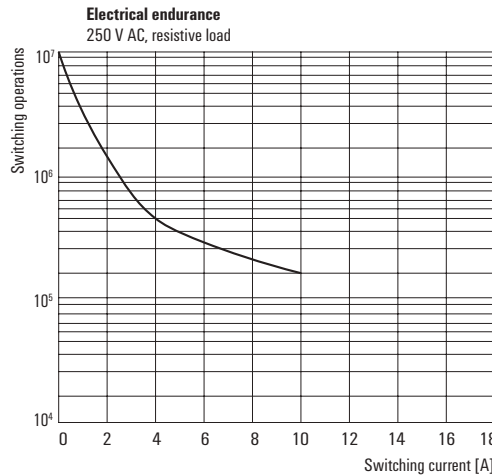
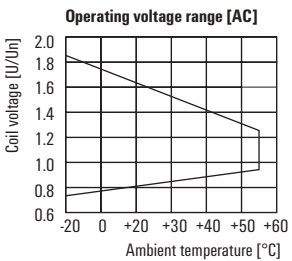
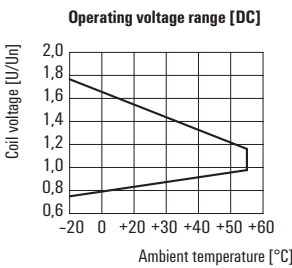

**DRL power relay**  
**3 CO contact, AC/DC coil**

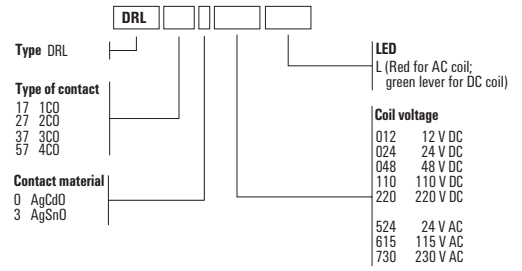

**Ordering data**

	12 V DC	24 V DC	48 V DC	110 V DC	220 V DC
<b>Control side</b>					
Rated control voltage	12 V DC	24 V DC	48 V DC	110 V DC	220 V DC
Rated current AC / DC	/ 120 mA	/ 60 mA	/ 30 mA	/ 13.1 mA	/ 6.7 mA
Power rating	1.4 W	1.4 W	1.4 W	1.4 W	1.4 W
Status indicator	Green LED	Green LED	Green LED	Green LED	Green LED

Ordering data						
3 CO contacts	Type	DRL373012L	DRL373024L	DRL373048L	DRL373110L	DRL373220L
	Order No.	<b>2765210000</b>	<b>2765220000</b>	<b>2765230000</b>	<b>2765240000</b>	<b>2765250000</b>
	Type					
	Order No.					
<b>Note</b>						

**Ordering data**

	24 V AC	115 V AC	230 V AC
<b>Control side</b>			
Rated control voltage	24 V AC	115 V AC	230 V AC
Rated current AC / DC	80 mA /	16 mA /	10 mA /
Power rating	2 VA	2 VA	2 VA
Status indicator	red LED	red LED	red LED

Ordering data				
3 CO contacts	Type	DRL373524L	DRL373615L	DRL373730L
	Order No.	<b>2765430000</b>	<b>2765440000</b>	<b>2765450000</b>
	Type			
	Order No.			
<b>Note</b>				

**DRL power relay**  
**4 CO contact, AC/DC coil**

- High wear resistance in case of AC loads
- High dielectric strength: 2,000 V



**B**

**Circuit diagram**  
**View on pins from below**

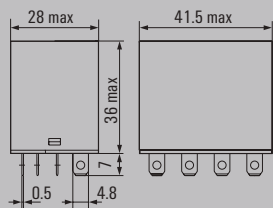
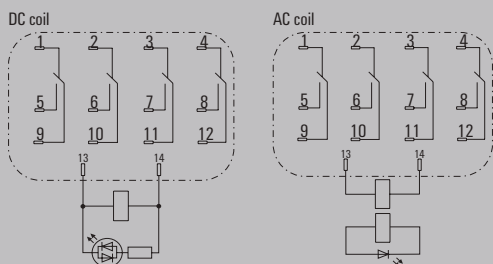

**Technical data**

Load side	
Rated switching voltage / Continuous current	250 V AC / 10 A
Max. switching voltage, AC	250 V
Inrush current	50 A / 50 ms
Min. switching power	10 mA @ 12 V
Contact type	4 CO contact (AgSnO)
Mechanical service life	10 x 10 <sup>6</sup> switching cycles
Max. switching frequency at rated load	0.1 Hz
General data	
Ambient temperature (operational)	-25 °C...55 °C
Storage temperature	-25 °C...55 °C
Humidity	35 % to 85 % relative humidity level
Approvals	cURus
Insulation coordinates	
Rated voltage	250 V
Impulse withstand voltage	5 kV (1.2/50 µs)
Dielectric strength for control side - load side	2.5 kV <sub>eff</sub> / 1 min
Dielectric strength of neighbouring contacts	2 kV <sub>eff</sub> / 1 min
Dielectric strength to mounting rail	
Clearance and creepage distances for control side - load side	≥ 4 mm
Overvoltage category	III
Pollution degree	3

Dimensions	Flat blade connections (4.8 mm x 0.5 mm)
Depth x width x height	mm 36 / 41.5 / 28

**Note** Further technical data can be found at [eshop.weidmueller.com](http://eshop.weidmueller.com)

**Applications**

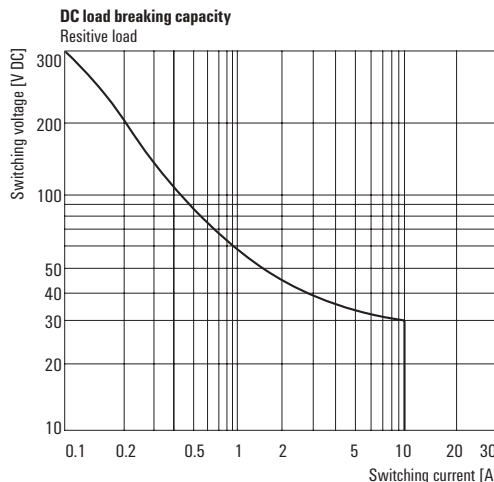
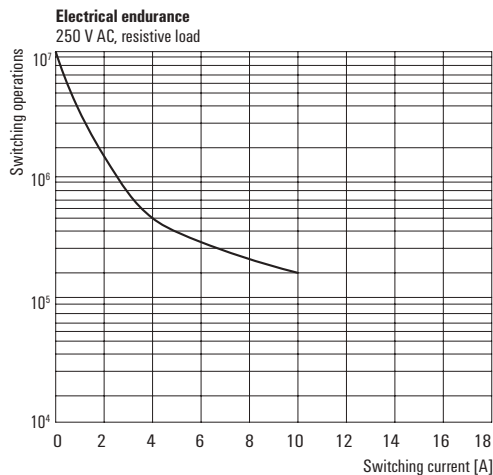
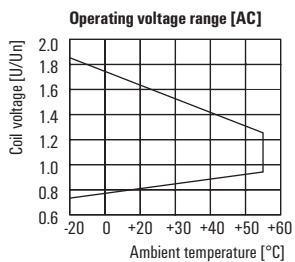
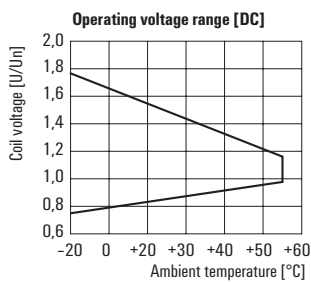

**DRL power relay**  
**4 CO contact, AC/DC coil**

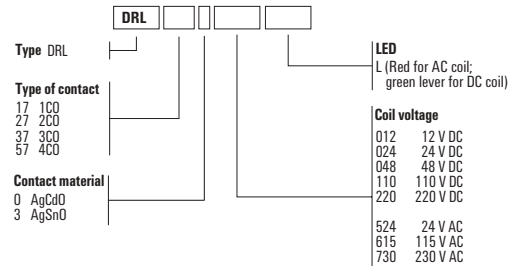

**Ordering data**

	12 V DC	24 V DC	48 V DC	110 V DC	220 V DC
<b>Control side</b>					
Rated control voltage	12 V DC	24 V DC	48 V DC	110 V DC	220 V DC
Rated current AC / DC	/ 125 mA	/ 66.7 mA	/ 31.2 mA	/ 16.2 mA	/ 7.6 mA
Power rating	1.5 W	1.5 W	1.5 W	1.5 W	1.5 W
Status indicator	Green LED	Green LED	Green LED	Green LED	Green LED

Ordering data						
4 CO contacts	Type	DRL573012L	DRL573024L	DRL573048L	DRL573110L	DRL573220L
	Order No.	<b>2765260000</b>	<b>2765270000</b>	<b>2765280000</b>	<b>2765290000</b>	<b>2765300000</b>
	Type					
	Order No.					
<b>Note</b>						

**Ordering data**

	24 V AC	115 V AC	230 V AC
<b>Control side</b>			
Rated control voltage	24 V AC	115 V AC	230 V AC
Rated current AC / DC	/ 93.5 mA	/ 25.5 mA	/ 13.1 mA
Power rating	2.5 VA	2.5 VA	2.5 VA
Status indicator	red LED	red LED	red LED

Ordering data				
4 CO contacts	Type	DRL573524L	DRL573615L	DRL573730L
	Order No.	<b>2765460000</b>	<b>2765470000</b>	<b>2765480000</b>
	Type			
	Order No.			
<b>Note</b>				

Accessories for DRL relays

Socket module with leaf spring connection, 2 CO contacts

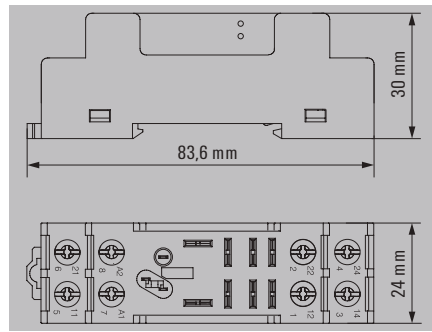

Socket module with leaf spring connection, 3 CO contacts

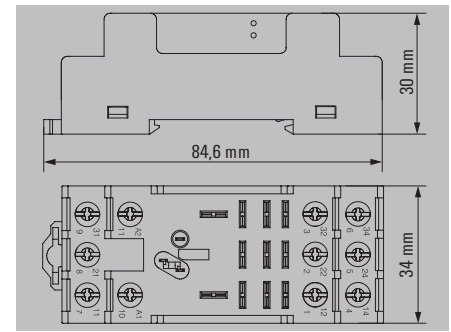

Technical data

<b>Load side</b>	
Rated switching voltage	250 V AC
Max. switching voltage, AC	250 V
Continuous current	10 A
<b>General data</b>	
Ambient temperature (operational)	-40 °C...65 °C
Storage temperature	-40 °C...85 °C
Approvals	CE; cURus; UKCA
<b>Insulation coordinates</b>	
Protection degree	IP10
Clearance and creepage distances for control side - load side	≥ 6 mm
Dielectric strength for control side - load side	2 kV <sub>eff</sub> / 1 min
Dielectric strength of neighbouring contacts	2 kV <sub>eff</sub> / 1 min
Impulse withstand voltage	4 kV (1.2/50 µs)
<b>Connection data</b>	
Clamping range (nominal / min. / max.)	/ 0.5 / 2.5 mm <sup>2</sup>
Tightening torque	0.8...1 Nm
Stripping length, rated connection	8 mm
<b>Note</b>	

<b>Load side</b>	
Rated switching voltage	250 V AC
Max. switching voltage, AC	250 V
Continuous current	10 A
<b>General data</b>	
Ambient temperature (operational)	-40 °C...65 °C
Storage temperature	-40 °C...85 °C
Approvals	CE; cURus; UKCA
<b>Insulation coordinates</b>	
Protection degree	IP10
Clearance and creepage distances for control side - load side	≥ 6 mm
Dielectric strength for control side - load side	2 kV <sub>eff</sub> / 1 min
Dielectric strength of neighbouring contacts	2 kV <sub>eff</sub> / 1 min
Impulse withstand voltage	4 kV (1.2/50 µs)
<b>Connection data</b>	
Clamping range (nominal / min. / max.)	/ 0.5 / 2.5 mm <sup>2</sup>
Tightening torque	0.8...1 Nm
Stripping length, rated connection	8 mm
<b>Note</b>	

<b>Load side</b>	
Rated switching voltage	250 V AC
Max. switching voltage, AC	250 V
Continuous current	10 A
<b>General data</b>	
Ambient temperature (operational)	-40 °C...65 °C
Storage temperature	-40 °C...85 °C
Approvals	CE; cURus; UKCA
<b>Insulation coordinates</b>	
Protection degree	IP10
Clearance and creepage distances for control side - load side	≥ 6 mm
Dielectric strength for control side - load side	2 kV <sub>eff</sub> / 1 min
Dielectric strength of neighbouring contacts	2 kV <sub>eff</sub> / 1 min
Impulse withstand voltage	4 kV (1.2/50 µs)
<b>Connection data</b>	
Clamping range (nominal / min. / max.)	/ 0.5 / 2.5 mm <sup>2</sup>
Tightening torque	0.8...1 Nm
Stripping length, rated connection	8 mm
<b>Note</b>	

Ordering data

	Base, rail-mountable
<b>Note</b>	

Type	Qty.	Order No.
SLD F 2CO	10	7760056225

Type	Qty.	Order No.
SLD F 3CO	10	7760056226

Accessories

<b>Retaining clip</b>	Metal retaining clip
<b>LED module / protection modules</b>	<ul style="list-style-type: none"> <li>LED 110 - 230 V UC green</li> <li>LED 24 - 60 V UC green</li> <li>LED 6 - 24 V UC green</li> <li>LED 110 - 230 V DC green and free-wheeling diode</li> <li>LED 24 - 60 V DC green and free-wheeling diode</li> <li>LED 6 - 24 V DC green and free-wheeling diode</li> <li>Free-wheeling diode 6 - 230 V DC</li> <li>RC element 110 - 230 V AC; 4.7 kΩ / 10 nF</li> <li>RC element 110 - 230 V AC; 100 Ω / 220 nF and LED green</li> <li>RC element 6 - 230 V AC</li> </ul>
<b>Screwdriver</b>	<ul style="list-style-type: none"> <li>Screwdriver, insulated PH2 SlimLine</li> <li>Screwdriver, insulated PH2</li> <li>Screwdriver PH2</li> </ul>

Type	Qty.	Order No.
DRM/DRL CLIP M	10	7760056108
RIM 3 110/230VUC	10	7940018455
RIM 3 24/60VUC	10	7760056018
RIM 3 6/24VUC	10	7940018457
RIM 2 110/230VDC	10	7760056017
RIM 2 24/60VDC	10	7760056016
RIM 2 6/24VDC	10	7760056015
RIM 1 6/230VDC	10	7760056169
RIM 3 110/230VAC	10	7760056014
RIM 3 110/230VAC LED	10	7760056045
SDIK SLIM PH2 X 100	1	2749660000
SDIK PH2 X 100	1	2749900000
SDK PH2 X 100	1	2749420000

Type	Qty.	Order No.
SLD CLIP 3CO M	10	7760056234
RIM 3 110/230VUC	10	7940018455
RIM 3 24/60VUC	10	7760056018
RIM 3 6/24VUC	10	7940018457
RIM 2 110/230VDC	10	7760056017
RIM 2 24/60VDC	10	7760056016
RIM 2 6/24VDC	10	7760056015
RIM 1 6/230VDC	10	7760056169
RIM 3 110/230VAC	10	7760056014
RIM 3 110/230VAC LED	10	7760056045
SDIK SLIM PH2 X 100	1	2749660000
SDIK PH2 X 100	1	2749900000
SDK PH2 X 100	1	2749420000

**Note**

Further accessories can be found on the article at [eshop.weidmueller.com](http://eshop.weidmueller.com)

Further accessories can be found on the article at [eshop.weidmueller.com](http://eshop.weidmueller.com)

**Socket module with leaf spring connection, 4 CO contacts**

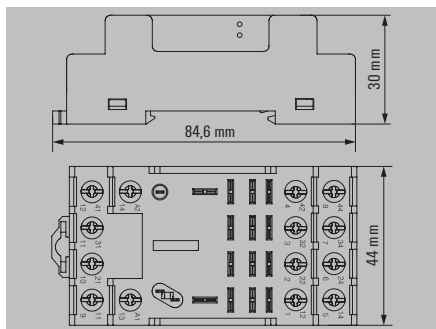

250 V AC
250 V
10 A
-40 °C...65 °C
-40 °C...85 °C
CE; cURus; UKCA
IP10
≥ 6 mm
2 kV <sub>eff</sub> / 1 min
2 kV <sub>eff</sub> / 1 min
4 kV (1.2/50 µs)
/ 0.5 / 2.5 mm <sup>2</sup>
0.8...1 Nm
8 mm

Type	Qty.	Order No.
SLD F 4CO	10	7760056227

Type	Qty.	Order No.
SLD CLIP 4CO M	10	7760056235
RIM 5 6/230VDC	10	1174650000
RIM 5 6/230VAC	10	1174670000
SDIK SLIM PH2 X 100	1	2749660000
SDIK PH2 X 100	1	2749900000
SDK PH2 X 100	1	2749420000

Further accessories can be found on the article at [eshop.weidmueller.com](http://eshop.weidmueller.com)

**DRW power relay**

**2 CO contact, AC/DC coil**

**3 CO contact, AC/DC coil**

- Suitable for switching high load voltages
- With LED and test button



**Circuit diagram**

View on pins from below

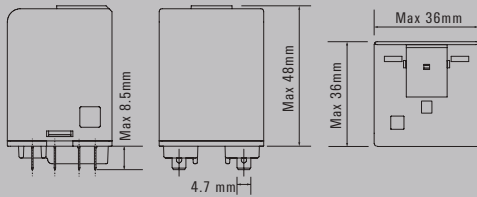
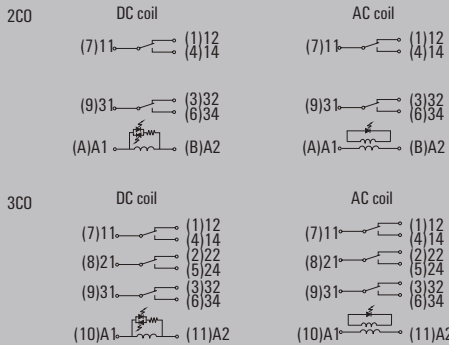

**Technical data**

Load side	
Rated switching voltage / Continuous current	400 VAC / 16 A
Max. switching voltage, AC	400 V
Inrush current	80 A / 50 ms
Min. switching power	100 mA @ 12 V
Contact type	2 CO contact (AgSnO)
Mechanical service life	20 x 10 <sup>6</sup> switching cycles
Max. switching frequency at rated load	0.1 Hz
General data	
Ambient temperature (operational)	-40 °C...60 °C
Storage temperature	-40 °C...60 °C
Humidity	5...85 % rel. humidity, no condensation
Approvals	cURus
Insulation coordinates	
Rated voltage	400 V
Impulse withstand voltage	
Dielectric strength for control side - load side	4 kV <sub>eff</sub> / 1 Min.
Dielectric strength of neighbouring contacts	4 kV <sub>eff</sub> / 1 Min.
Dielectric strength to mounting rail	
Clearance and creepage distances for control side - load side	≥ 6,3 mm
Overvoltage category	III
Pollution degree	3

Dimensions	Flat blade connections (4.8 mm x 0.5 mm)
Depth x width x height	mm 48 / 36 / 36

**Note** Further technical data can be found at [eshop.weidmueller.com](http://eshop.weidmueller.com)

**Applications**

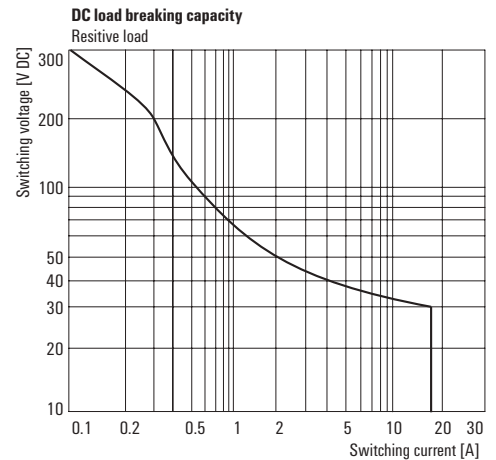
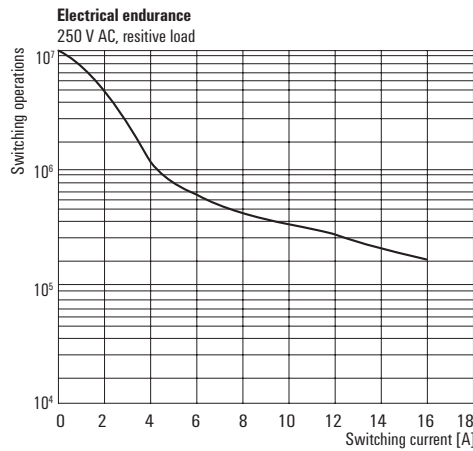
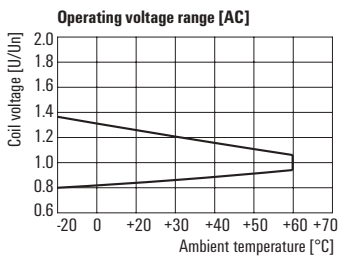
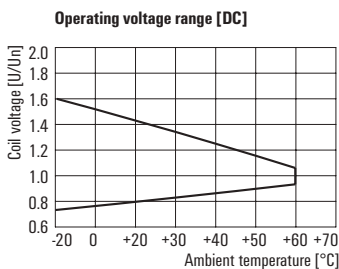

**DRW power relay**  
**2 CO contact, AC/DC coil**  
**3 CO contact, AC/DC coil**

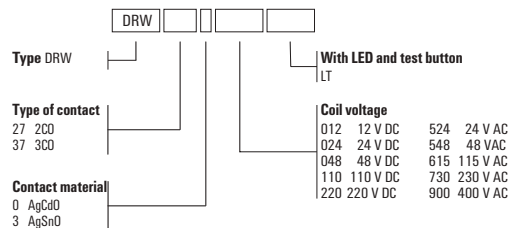

Ordering data	12 V DC	24 V DC	48 V DC	110 V DC	220 V DC
<b>Control side</b>					
Rated control voltage	12 V DC	24 V DC	48 V DC	110 V DC	220 V DC
Rated current AC / DC	/ 120 mA	/ 60 mA	/ 30 mA	/ 13 mA	/ 6.7 mA
Power rating	1.7 W	1.7 W	1.7 W	1.7 W	1.7 W
Status indicator	Green LED	Green LED	Green LED	Green LED	Green LED

Ordering data						
2 CO contacts	Type	DRW273012LT	DRW273024LT	DRW273048LT	DRW273110LT	DRW273220LT
	Order No.	<b>2765590000</b>	<b>2765600000</b>	<b>2765610000</b>	<b>2765620000</b>	<b>2765630000</b>
3 CO contacts	Type	DRW373012LT	DRW373024LT	DRW373048LT	DRW373110LT	DRW373220LT
	Order No.	<b>2765640000</b>	<b>2765650000</b>	<b>2765660000</b>	<b>2765670000</b>	<b>2765680000</b>

Note					

Ordering data	24 V AC	48 V AC	115 V AC	230 V AC	400 V AC
<b>Control side</b>					
Rated control voltage	24 V AC	48 V AC	115 V AC	230 V AC	400 V AC
Rated current AC / DC	101.7 mA /	50.5 mA /	21 mA /	10,6 mA /	6.1 mA /
Power rating	2.5 VA	2.5 VA	2.5 VA	2.5 VA	2.5 VA
Status indicator	red LED	red LED	red LED	red LED	red LED

Ordering data						
2 CO contacts	Type	DRW273524LT	DRW273548LT	DRW273615LT	DRW273730LT	DRW273900LT
	Order No.	<b>2765490000</b>	<b>2765500000</b>	<b>2765510000</b>	<b>2765520000</b>	<b>2765530000</b>
3 CO contacts	Type	DRW373524LT	DRW373548LT	DRW373615LT	DRW373730LT	DRW373900LT
	Order No.	<b>2765540000</b>	<b>2765550000</b>	<b>2765560000</b>	<b>2765570000</b>	<b>2765580000</b>

Note					

**DRH DC relay**

- 1 NO contact AC/DC coil**
- 1 NC contact AC/DC coil**

- Suitable for switching high DC loads
- With blowout magnet
- With LED and test button
- For switching high DC loads up to 10 A at 220 V DC



**Circuit diagram**

View on pins from below

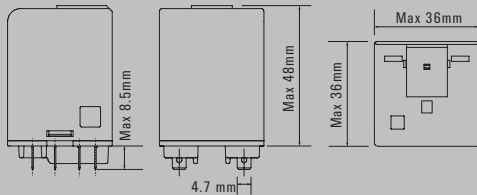
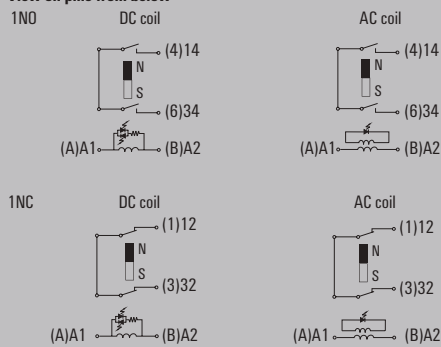

**Technical data**

Load side	
Rated switching voltage / Continuous current	500 V AC / 16 A
Max. switching voltage, AC	400 V
Inrush current	80 A / 50 ms
Min. switching power	100 mA @ 12 V
DC / AC Switching capacity (resistive), max.	2200 W @ 220 V / 8000 VA
Contact material	AgSnO
Mechanical service life	10 x 10 <sup>6</sup> switching cycles
Max. switching frequency at rated load	0.1 Hz
General data	
Ambient temperature (operational)	-40 °C...60 °C
Storage temperature	-40 °C...60 °C
Humidity	5...85 % rel. humidity, no condensation
Approvals	cURus
Insulation coordinates	
Rated voltage	500 V
Impulse withstand voltage	
Dielectric strength for control side - load side	4 kV <sub>eff</sub> / 1 min
Dielectric strength of neighbouring contacts	
Dielectric strength to mounting rail	
Clearance and creepage distances for control side - load side	≥ 8 mm
Overvoltage category	III
Pollution degree	3
Dimensions	
Flat blade connections (4.8 mm x 0.5 mm)	
Depth x width x height	mm 48 / 36 / 36
Note	
Further technical data can be found at <a href="http://eshop.weidmueller.com">eshop.weidmueller.com</a>	

**Applications**

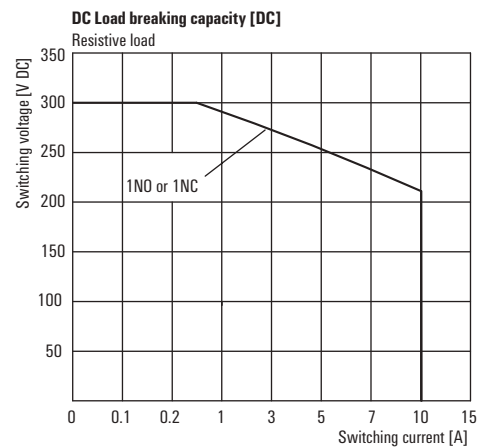
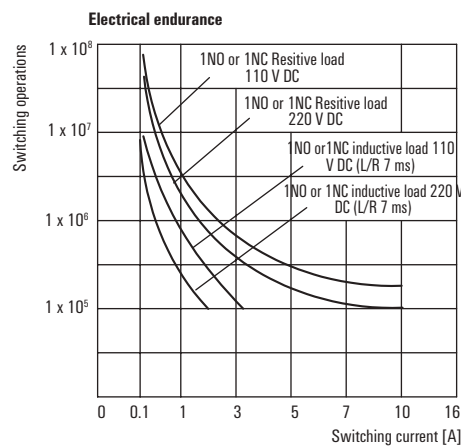
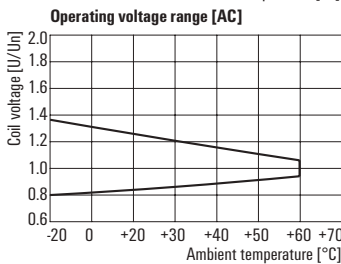
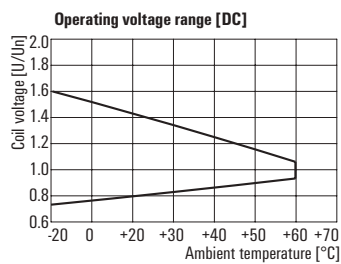

**DRH DC relay**  
**1 NO contact AC/DC coil**  
**1 NC contact AC/DC coil**

Type  
 DRH

Type of contact  
 173 1NO  
 174 1NC

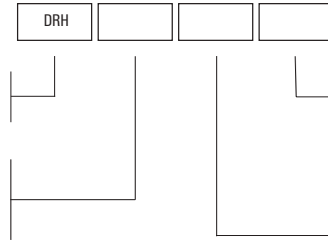

With LED and test lever			
		LT	
Coil voltage			
012	12 V DC	524	24 V AC
024	24 V DC	548	48 V AC
048	48 V DC	615	115 V AC
110	110 V DC	730	230 V AC
220	220 V DC		

**Ordering data**

	12 V DC	24 V DC	48 V DC	110 V DC	220 V DC
<b>Control side</b>					
Rated control voltage	12 V DC	24 V DC	48 V DC	110 V DC	220 V DC
Rated current AC / DC	/ 120 mA	/ 60 mA	/ 30 mA	/ 13 mA	/ 6.7 mA
Power rating	1.5 W	1.5 W	1.5 W	1.5 W	1.5 W
Status indicator	Green LED	Green LED	Green LED	Green LED	red LED

**Ordering data**

1 NO contact	Type DRH173012LT	Type DRH173024LT	Type DRH173048LT	Type DRH173110LT	Type DRH173220LT
	Order No. 1219840000	Order No. 1219850000	Order No. 1219860000	Order No. 1219870000	Order No. 1219880000
1 NC contact	Type DRH174012LT	Type DRH174024LT	Type DRH174048LT	Type DRH174110LT	Type DRH174220LT
	Order No. 1219940000	Order No. 1219950000	Order No. 1219960000	Order No. 1219970000	Order No. 1219980000

**Ordering data**  
**Test-button lock**

Type	TEST LEVER BLOCK DRH/DRW	TEST LEVER BLOCK DRH/DRW	TEST LEVER BLOCK DRH/DRW	TEST LEVER BLOCK DRH/DRW	TEST LEVER BLOCK DRH/DRW
Order No.	7760056249	7760056249	7760056249	7760056249	7760056249

**Note**

**Ordering data**

	24 V AC	48 V AC	115 V AC	230 V AC
<b>Control side</b>				
Rated control voltage	24 V AC	48 V AC	115 V AC	230 V AC
Rated current AC / DC	101.7 mA /	50.5 mA /	21 mA /	10,6 mA /
Power rating	2.5 VA	2.5 VA	2.5 VA	2.5 VA
Status indicator	red LED	red LED	red LED	red LED

**Ordering data**

1 NO contact	Type DRH173524LT	Type DRH173548LT	Type DRH173615LT	Type DRH173730LT
	Order No. 1219890000	Order No. 1219910000	Order No. 1219920000	Order No. 1219930000
1 NC contact	Type DRH174524LT	Type DRH174548LT	Type DRH174615LT	Type DRH174730LT
	Order No. 1219990000	Order No. 1220010000	Order No. 1220020000	Order No. 1220030000

**Ordering data**  
**Test-button lock**

Type	TEST LEVER BLOCK DRH/DRW	TEST LEVER BLOCK DRH/DRW	TEST LEVER BLOCK DRH/DRW	TEST LEVER BLOCK DRH/DRW
Order No.	7760056249	7760056249	7760056249	7760056249

**Note**

**DRH DC relay**

**1 NO contact / 1 NC contact AC/DC coil**

- Suitable for switching high DC loads
- With blowout magnet
- With LED and test button
- For switching high DC loads up to 3 A at 220 V DC



**Circuit diagram**  
View on pins from below

1NO/1NC

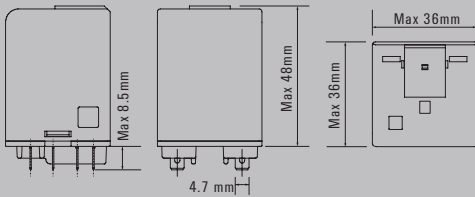
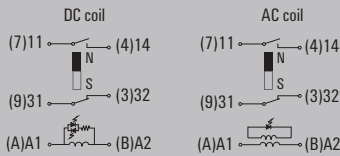

**Technical data**

Load side	
Rated switching voltage / Continuous current	250 V AC / 16 A
Max. switching voltage, AC	400 V
Inrush current	80 A / 50 ms
Min. switching power	100 mA @ 12 V
DC / AC Switching capacity (resistive), max.	660 W @ 220 V / 4000 VA
Contact material	AgSnO
Mechanical service life	10 x 10 <sup>6</sup> switching cycles
Max. switching frequency at rated load	0.1 Hz
General data	
Ambient temperature (operational)	-40 °C...60 °C
Storage temperature	-40 °C...60 °C
Humidity	5...85 % rel. humidity, no condensation
Approvals	cURus
Insulation coordinates	
Rated voltage	400 V
Impulse withstand voltage	
Dielectric strength for control side - load side	4 kV <sub>eff</sub> / 1 min
Dielectric strength of neighbouring contacts	4 kV <sub>eff</sub> / 1 min
Dielectric strength to mounting rail	
Clearance and creepage distances for control side - load side	≥ 6,3 mm
Overvoltage category	III
Pollution degree	3
Dimensions	
Flat blade connections (4.8 mm x 0.5 mm)	
Depth x width x height	mm 48 / 36 / 36
Note	
Further technical data can be found at <a href="http://eshop.weidmueller.com">eshop.weidmueller.com</a>	

**Applications**

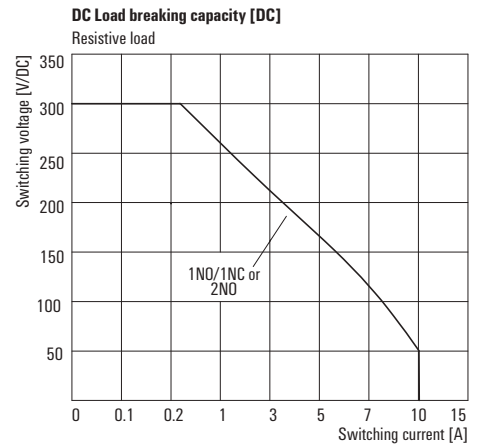
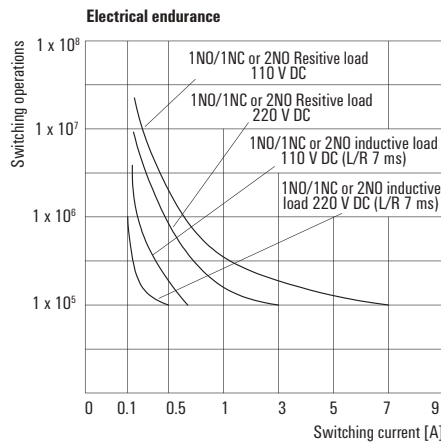
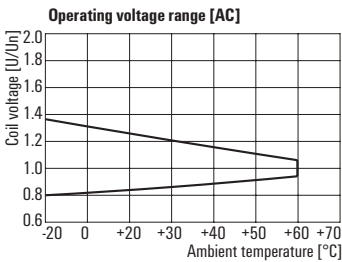
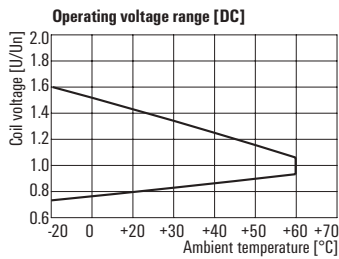

**DRH DC relay**

**1 NO contact / 1 NC contact AC/DC coil**

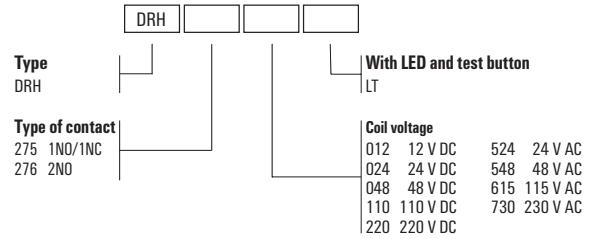

**Ordering data**

	12 V DC	24 V DC	48 V DC	110 V DC	220 V DC
<b>Control side</b>					
Rated control voltage	12 V DC	24 V DC	48 V DC	110 V DC	220 V DC
Rated current AC / DC	/ 120 mA	/ 60 mA	/ 30 mA	/ 13 mA	/ 6.7 mA
Power rating	1.5 W	1.5 W	1.5 W	1.5 W	1.5 W
Status indicator	Green LED	Green LED	Green LED	Green LED	Green LED

Ordering data	12 V DC	24 V DC	48 V DC	110 V DC	220 V DC
1 NO / 1 NC contact	DRH275012LT	DRH275024LT	DRH275048LT	DRH275110LT	DRH275220LT
Type					
Order No.	1220040000	1220050000	1220060000	1220070000	1220080000
Type					
Order No.					
<b>Ordering data</b>					
<b>Test-button lock</b>					
Type	TEST LEVER BLOCK DRH/DRW	TEST LEVER BLOCK DRH/DRW	TEST LEVER BLOCK DRH/DRW	TEST LEVER BLOCK DRH/DRW	TEST LEVER BLOCK DRH/DRW
Order No.	7760056249	7760056249	7760056249	7760056249	7760056249
<b>Note</b>					

**Ordering data**

	24 V AC	48 V AC	115 V AC	230 V AC
<b>Control side</b>				
Rated control voltage	24 V AC	48 V AC	115 V AC	230 V AC
Rated current AC / DC	101.7 mA /	50.5 mA /	21 mA /	10,6 mA /
Power rating	2.5 VA	2.5 VA	2.5 VA	2.5 VA
Status indicator	red LED	red LED	red LED	red LED

Ordering data	24 V AC	48 V AC	115 V AC	230 V AC
1 NO / 1 NC contact	DRH275524LT	DRH275548LT	DRH275615LT	DRH275730LT
Type				
Order No.	1220090000	1220110000	1220120000	1220130000
Type				
Order No.				
<b>Ordering data</b>				
<b>Test-button lock</b>				
Type	TEST LEVER BLOCK DRH/DRW	TEST LEVER BLOCK DRH/DRW	TEST LEVER BLOCK DRH/DRW	TEST LEVER BLOCK DRH/DRW
Order No.	7760056249	7760056249	7760056249	7760056249
<b>Note</b>				

**DRH DC relay**

**2 NO contact AC/DC coil**

- Suitable for switching high DC loads
- With blowout magnet
- With LED and test button
- For switching high DC loads up to 3 A at 220 V DC



**Circuit diagram**  
View on pins from below

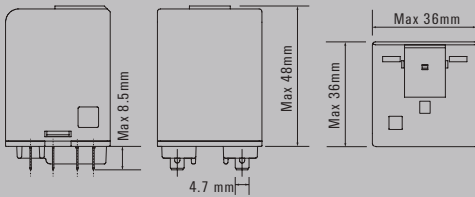
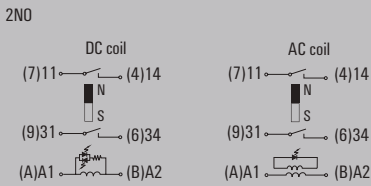

**Technical data**

Load side	
Rated switching voltage / Continuous current	250 V AC / 16 A
Max. switching voltage, AC	400 V
Inrush current	80 A / 50 ms
Min. switching power	100 mA @ 12 V
DC / AC Switching capacity (resistive), max.	660 W @ 220 V / 4000 VA
Contact material	AgSnO
Mechanical service life	10 x 10 <sup>6</sup> switching cycles
Max. switching frequency at rated load	0.1 Hz
General data	
Ambient temperature (operational)	-40 °C...60 °C
Storage temperature	-40 °C...60 °C
Humidity	5...85 % rel. humidity, no condensation
Approvals	cURus
Insulation coordinates	
Rated voltage	400 V
Impulse withstand voltage	
Dielectric strength for control side - load side	4 kV <sub>eff</sub> / 1 min
Dielectric strength of neighbouring contacts	4 kV <sub>eff</sub> / 1 min
Dielectric strength to mounting rail	
Clearance and creepage distances for control side - load side	≥ 6,3 mm
Overvoltage category	III
Pollution degree	3
Dimensions	
Flat blade connections (4.8 mm x 0.5 mm)	
Depth x width x height	mm 48 / 36 / 36
Note	
Further technical data can be found at <a href="http://eshop.weidmueller.com">eshop.weidmueller.com</a>	

**Applications**

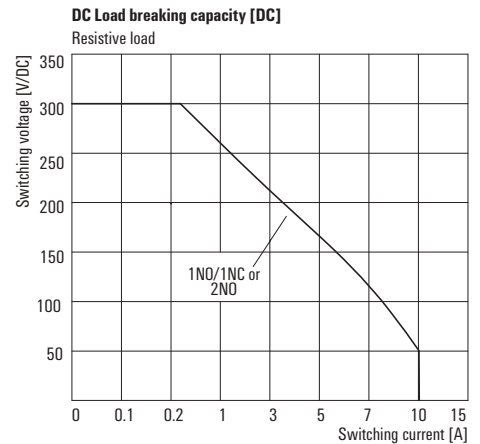
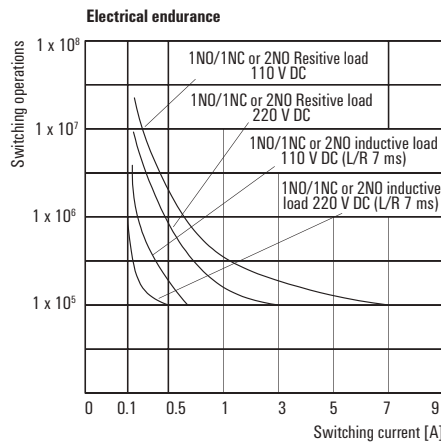
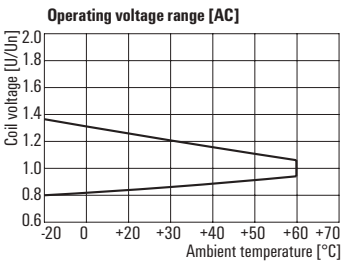
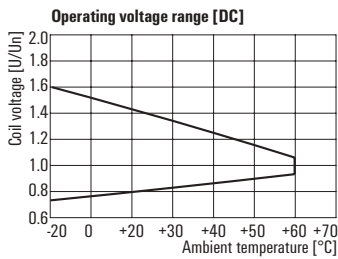

**DRH DC relay**  
**2 NO contact AC/DC coil**

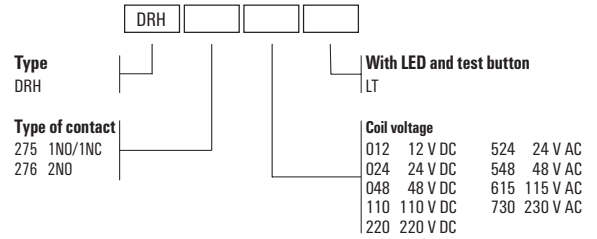

**Ordering data**

	12 V DC	24 V DC	48 V DC	110 V DC	220 V DC
<b>Control side</b>					
Rated control voltage	12 V DC	24 V DC	48 V DC	110 V DC	220 V DC
Rated current AC / DC	/ 120 mA	/ 60 mA	/ 30 mA	/ 13 mA	/ 6.7 mA
Power rating	1.5 W	1.5 W	1.5 W	1.5 W	1.5 W
Status indicator	Green LED	Green LED	Green LED	Green LED	Green LED

Ordering data						
2 NO contacts	Type	DRH276012LT	DRH276024LT	DRH276048LT	DRH276110LT	DRH276220LT
	Order No.	1220140000	1220150000	1220170000	1220180000	1220190000
	Type					
Ordering data	Type	TEST LEVER BLOCK DRH/DRW	TEST LEVER BLOCK DRH/DRW	TEST LEVER BLOCK DRH/DRW	TEST LEVER BLOCK DRH/DRW	TEST LEVER BLOCK DRH/DRW
	Order No.	7760056249	7760056249	7760056249	7760056249	7760056249
Note						

**Ordering data**

	24 V AC	48 V AC	115 V AC	230 V AC
<b>Control side</b>				
Rated control voltage	24 V AC	48 V AC	115 V AC	230 V AC
Rated current AC / DC	101.7 mA /	50.5 mA /	21 mA /	10,6 mA /
Power rating	2.5 VA	2.5 VA	2.5 VA	2.5 VA
Status indicator	red LED	red LED	red LED	red LED

Ordering data					
2 NO contacts	Type	DRH276524LT	DRH276548LT	DRH276615LT	DRH276730LT
	Order No.	1220200000	1220210000	1220220000	1220230000
	Type				
Ordering data	Type	TEST LEVER BLOCK DRH/DRW	TEST LEVER BLOCK DRH/DRW	TEST LEVER BLOCK DRH/DRW	TEST LEVER BLOCK DRH/DRW
	Order No.	7760056249	7760056249	7760056249	7760056249
Note					

Accessories for DRH and DRW relays

Socket module with leaf spring connection, 3 CO contacts

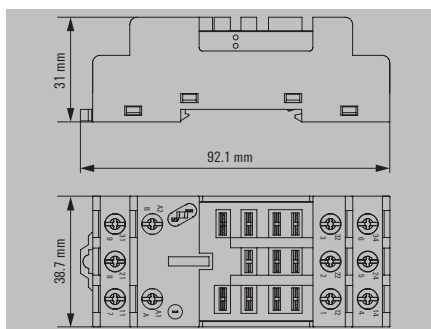

Technical data

<b>Load side</b>	
Rated switching voltage	250 V AC
Max. switching voltage, AC	250 V
Continuous current	16 A
<b>General data</b>	
Ambient temperature (operational)	-40 °C...60 °C
Storage temperature	-40 °C...60 °C
Approvals	CE, cURus, UKCA
<b>Insulation coordinates</b>	
Protection degree	IP10
Clearance and creepage distances for control side - load side	
Dielectric strength for control side - load side	4 kV <sub>eff</sub> / 1 min
Dielectric strength of neighbouring contacts	4 kV <sub>eff</sub> / 1 min
Impulse withstand voltage	7.3 kV (1.2/50 µs)
<b>Connection data</b>	
Clamping range (nominal / min. / max.)	/ 0.5 / 4 mm <sup>2</sup>
Tightening torque	0.5...1.2 Nm
Stripping length, rated connection	8 mm
<b>Note</b>	

Ordering data

	Base, rail-mountable		
<b>Note</b>			
<b>Type</b>	<b>Qty.</b>	<b>Order No.</b>	
SPW ECO 3CO	10	1220250000	

Accessories

<b>LED module / protection modules</b>		<b>Type</b>	<b>Qty.</b>	<b>Order No.</b>
RC element 6 - 230 V AC		RIM 5 6/230VAC	10	1174670000
Free-wheeling diode 6 - 230 V DC		RIM 5 6/230VDC	10	1174650000
<b>Retaining clip</b>	Metal retaining clip	DRW/DRH CLIP M	10	1220260000
<b>Screwdriver</b>		SDIK SLIM PH2 X 100	1	2749660000
Screwdriver, insulated PH2 SlimLine		SDIK PH2 X 100	1	2749900000
Screwdriver, insulated PH2		SDK PH2 X 100	1	2749420000
Screwdriver PH2				

**Note**

Further accessories can be found on the article at [eshop.weidmueller.com](http://eshop.weidmueller.com)



## MCZ-SERIES

### High reliability in a terminal block format

#### B

MCZ SERIES relay modules are among the smallest on the market. Thanks to the small width of just 6.1 mm, a lot of space can be saved in the panel. All products in the series have three cross-connection terminals and are distinguished by simple wiring with plug-in cross-connections. The tension clamp connection system, proven a million times over, and the integrated reverse polarity protection ensure a high level of safety during installation and operation. Precisely fitting accessories from cross-connectors to markers and end plates make the MCZ SERIES versatile and convenient to use.

#### **MCZ TRAK – tested according to DIN EN 50155**

- Variants of the MCZ TRAK type are particularly suitable for the transport sector
- Tested according to DIN EN 50155, they meet the special requirements for operating voltage, temperature range, shock and vibration resistance as required for use in the railway industry.



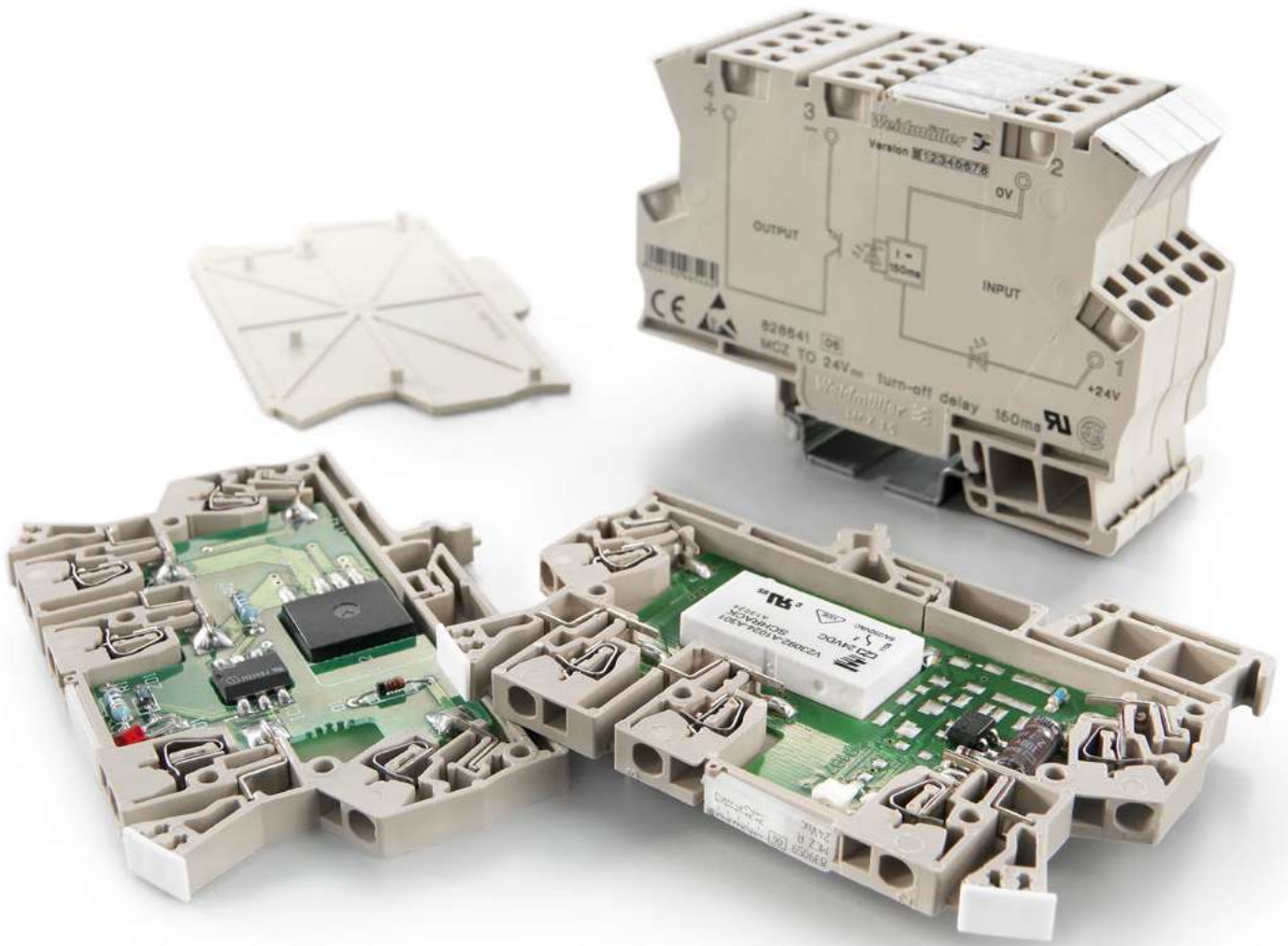

**MCZ R**

**1 CO contact AC/DC/UC coil**

The module can be used as a universal interface between the controller and the actuator to switch small and medium-sized loads

- Reduced installation and commissioning costs, thanks to the use of the proven tension-spring connection system
- Pluggable cross-connection at input and output minimises the wiring workload.
- Width 6 mm
- For mounting on TS 35

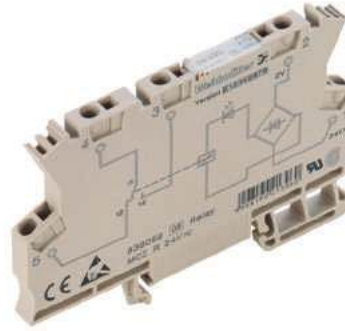

**Circuit diagram**

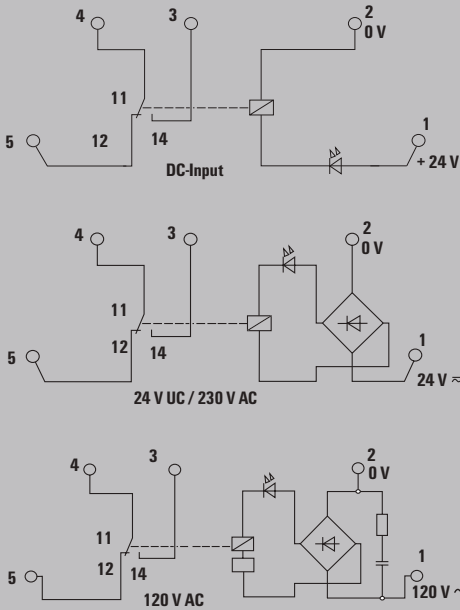

**Technical data**

Load side	
Rated switching voltage / Continuous current	250 V AC / 6 A
Max. switching voltage, AC	250 V
Inrush current	6 A
Min. switching power	1 mA @ 24 V, 10 mA @ 10 V, 100 mA @ 5 V
Contact type	1 CO contact (AgSnO)
Mechanical service life	10 x 10 <sup>8</sup> switching cycles
Max. switching frequency at rated load	0.1 Hz
General data	
Ambient temperature (operational)	-25 °C...50 °C
Storage temperature	-40 °C...60 °C
Humidity	5 - 93% rel. humidity, Tu = 40°C, no condensation
Approvals	CE; CSA; cURus; DETNORVER; UKCA
Insulation coordinates	
Rated voltage	300 V
Impulse withstand voltage	4 kV (1.2/50 µs)
Dielectric strength for control side - load side	4 kV <sub>eff</sub> / 1 s
Dielectric strength of neighbouring contacts	
Dielectric strength to mounting rail	4 kV <sub>eff</sub> / 1 Min.
Clearance and creepage distances for control side - load side	≥ 5.5 mm
Overvoltage category	III
Pollution degree	2
Dimensions	
Clamping range (nominal / min. / max.)	mm <sup>2</sup> 1.5 / 0.5 / 1.5
Depth x width x height	mm 63.2 / 6.1 / 9.1
Note	
End plate AP MCZ 1.5: 8389030000 Accessories and dimensional drawings: refer to the MCZ Accessories page.	

**Applications**

**Derating curve**

in a row without spacing on terminal rail  
in a row with 20 mm spacing on terminal rail

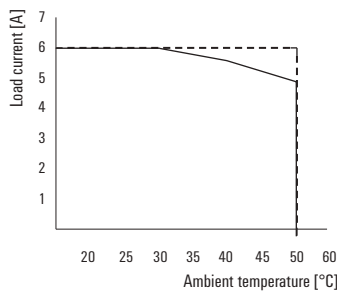

**Limit curve**

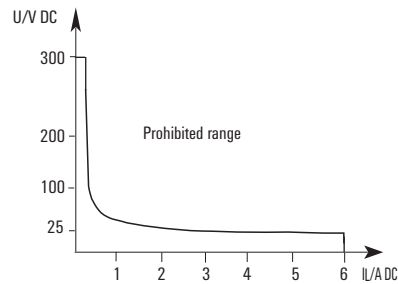

**MCZ R**  
1 CO contact AC/DC/UC coil

**Ordering data**

	24 V DC 1 CO	24 V DC 1 CO Au	24 V UC 1 CO	110 V DC 1 CO
<b>Control side</b>				
Rated control voltage	24 V DC ±20 %	24 V DC ±20 %	24 V UC ±10 %	110 V DC ±10 %
Rated current AC / DC	/ 6.3 mA	/ 6.3 mA	11 mA / 6.4 mA	/ 2.85 mA
Power rating	156 mW	156 mW	270 mVA / 154 mW	340 mW
Status indicator	Green LED	Green LED	Green LED	Green LED
Protective circuit	Free-wheeling diode, Reverse polarity protection	Free-wheeling diode, Reverse polarity protection	Rectifier	Rectifier

<b>Ordering data Complete module</b>					
CO contact	Type	MCZ R 24VDC	MCZ R 24VDC 5UAU	MCZ R 24VUC	MCZ R 110VDC
	Order No.	8365980000	8442960000	8390590000	8467470000
	Type				
	Order No.				

Note				

**Ordering data**

	120 V AC 1 CO	230 V AC 1 CO
<b>Control side</b>		
Rated control voltage	120 V AC -15 % / +10 %	230 V AC ±10 %
Rated current AC / DC	7 mA /	9.5 mA /
Power rating	0.85 VA	2.1 VA
Status indicator	Green LED	Green LED
Protective circuit	RC element, Rectifier	Rectifier

<b>Ordering data Complete module</b>			
CO contact	Type	MCZ R 120VAC	MCZ R 230VAC
	Order No.	8420880000	8237710000
	Type		
	Order No.		

Note		

**MCZ R TRAK**

**1 CO contact or 1 NO contact DC coil**

- 1 CO contact
- Component for rail industry applications
- Vibration requirements according to EN 61373, requirements category 1 class B
- Voltage fluctuations -30 %/+25 % and ±40 % for 0.1 sec
- Voltage interruptions at input up to 10 ms
- Condensation permissible

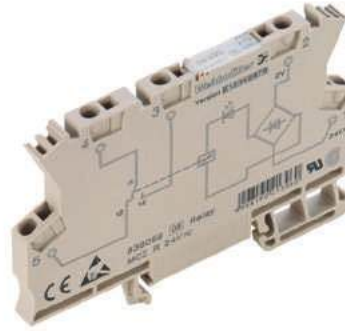

**B**

Circuit diagram

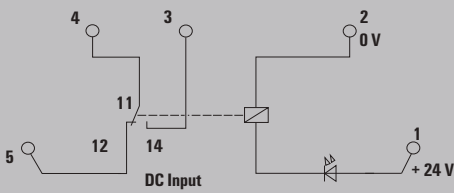

**Technical data**

Load side	
Rated switching voltage / Continuous current	250 V AC / 6 A
Max. switching voltage, AC	250 V
Inrush current	6 A
Min. switching power	100 mA @ 12 V
Contact type	1 CO contact (AgSnO)
Mechanical service life	10 x 10 <sup>6</sup> switching cycles
Max. switching frequency at rated load	0.1 Hz
General data	
Ambient temperature (operational)	-25 °C...70 °C
Storage temperature	-40 °C...85 °C
Humidity	95 % for 30 days, minimal condensation to EN 50155
Approvals	CE; UKCA
Insulation coordinates	
Rated voltage	300 V
Impulse withstand voltage	4 kV (1.2/50 µs)
Dielectric strength for control side - load side	4 kV <sub>eff</sub> / 1 s
Dielectric strength of neighbouring contacts	
Dielectric strength to mounting rail	4 kV <sub>eff</sub> / 1 Min.
Clearance and creepage distances for control side - load side	≥ 5.5 mm
Overvoltage category	III
Pollution degree	2

Dimensions	Tension-clamp connection	
Clamping range (nominal / min. / max.)	mm <sup>2</sup>	1.5 / 0.5 / 1.5
Depth x width x height	mm	63.2 / 6.1 / 91
<b>Note</b>	End plate AP MCZ 1.5: 8389030000 Accessories and dimensional drawings: refer to the MCZ Accessories page.	

**Applications**

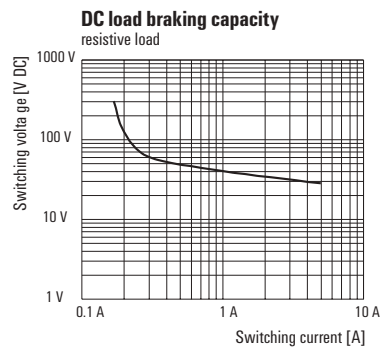
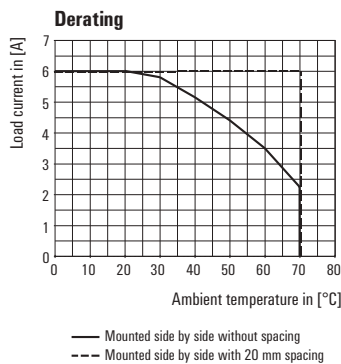

**MCZ R TRAK**

1 CO contact or 1 NO contact DC coil

**Ordering data**

	24 V DC TRAK	36 V DC TRAK	48...110 V DC TRAK
<b>Control side</b>			
Rated control voltage	24 V DC +25 % / -30 %	36 V DC +25 % / -30 %	48 V...110 V DC +25 % / -30 %
Rated current AC / DC	/ 11.5...16.5 mA	/ 8...12 mA	/ <3 mA
Power rating	195...500 mW	200...540 mW	<300 mW
Status indicator	Green LED	Green LED	Green LED
Protective circuit	Free-wheeling diode, Varistor, Reverse polarity protection	Free-wheeling diode, Varistor, Reverse polarity protection	Free-wheeling diode, Varistor, Reverse polarity protection

<b>Ordering data</b>				
<b>Complete module</b>				
CO contact	Type	MCZ R 24VDC 1CO TRAK	MCZ R 36VDC 1CO TRAK	MCZ R 48...110VDC 1CO TRAK
	Order No.	<b>8713890000</b>	<b>8713900000</b>	<b>8713910000</b>
NO contact	Type	MCZ R 24VDC 1NO TRAK		MCZ R 48...110VDC 1NO TRAK
	Order No.	<b>8499550000</b>		<b>8574070000</b>

<b>Note</b>			

**MCZ R TRAK Au**

**1 CO contact DC coil**

- 1 CO with hard gold-plated contacts
- Component for rail industry applications
- Vibration requirements according to EN 61373, requirements category 1 class B
- Voltage fluctuations -30 %/+25 % and ±40 % for 0.1 sec
- Voltage interruptions at input up to 10 ms
- Condensation permissible

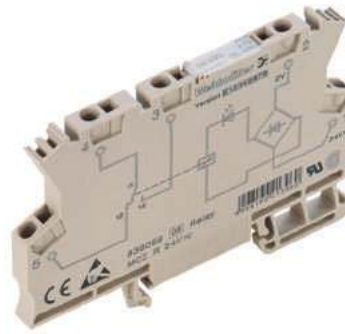

**B**

Circuit diagram

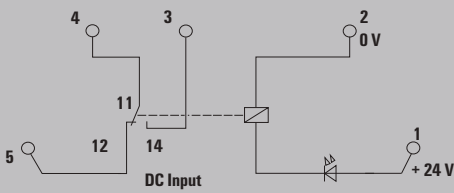

**Technical data**

Load side	
Rated switching voltage / Continuous current	250 V AC / 6 A
Max. switching voltage, AC	250 V
Inrush current	6 A
Min. switching power	1 mA @ 1 V
Contact type	1 CO contact (AgSnO gold-plated)
Mechanical service life	10 x 10 <sup>6</sup> switching cycles
Max. switching frequency at rated load	0.1 Hz
General data	
Ambient temperature (operational)	-25 °C...70 °C
Storage temperature	-40 °C...85 °C
Humidity	95 % for 30 days, minimal condensation to EN 50155
Approvals	CE; UKCA
Insulation coordinates	
Rated voltage	300 V
Impulse withstand voltage	4 kV (1.2/50 µs)
Dielectric strength for control side - load side	4 kV <sub>eff</sub> / 1 s
Dielectric strength of neighbouring contacts	
Dielectric strength to mounting rail	4 kV <sub>eff</sub> / 1 Min.
Clearance and creepage distances for control side - load side	≥ 5.5 mm
Overvoltage category	III
Pollution degree	2

Dimensions	Tension-clamp connection	
Clamping range (nominal / min. / max.)	mm <sup>2</sup>	1.5 / 0.5 / 1.5
Depth x width x height	mm	63.2 / 6.1 / 91
<b>Note</b>	End plate AP MCZ 1.5: 8389030000 Accessories and dimensional drawings: refer to the MCZ Accessories page.	

**Applications**

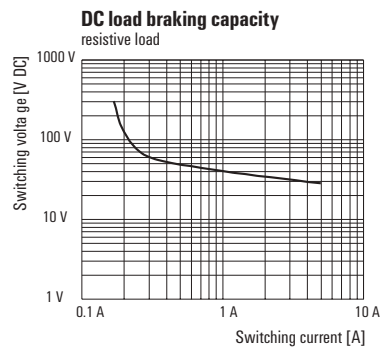
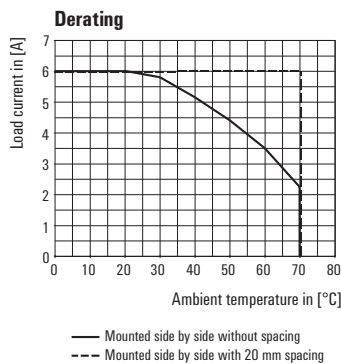

**MCZ R TRAK Au**  
**1 CO contact DC coil**

**Ordering data**

	24 V DC TRAK Au	36 V DC TRAK Au	48...110 V DC TRAK Au
<b>Control side</b>			
Rated control voltage	24 V DC +25 % / -30 %	36 V DC +25 % / -30 %	48 V...110 V DC +25 % / -30 %
Rated current AC / DC	/ 11.5...16.5 mA	/ 8...12 mA	/ <3 mA
Power rating	195...500 mW	200...540 mW	<300 mW
Status indicator	Green LED	Green LED	Green LED
Protective circuit	Free-wheeling diode, Varistor, Reverse polarity protection	Free-wheeling diode, Varistor, Reverse polarity protection	Free-wheeling diode, Varistor, Reverse polarity protection

Ordering data				
CO contact	Type	MCZ R 24VDC 1CO AU TRAK	MCZ R 36VDC 1CO AU TRAK	MCZ R 48...110VDC 1CO AU TRAK
	Order No.	8790520000	8790510000	8790500000
	Type			
	Order No.			

Note			

MCZ O

- Universal interface between controller and sensor/ actuator
- Tension-clamp connection system
- Plug-in cross-connection
- 6 mm modular wide

24 V UC



24 V UC / 24 V 2 A

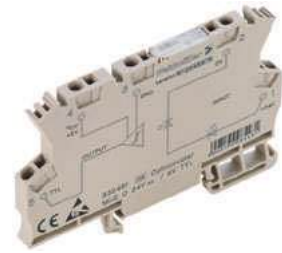

B

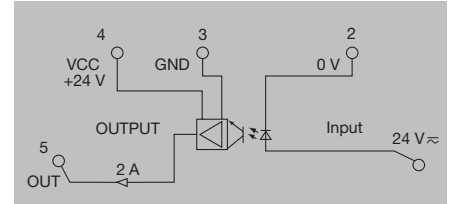
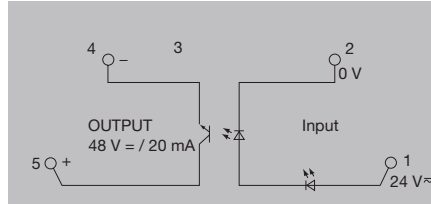

Technical data

Control side

Rated control voltage  
Nominal control current  
Input frequency  
Power rating  
Status indicator  
Protective circuit

24 V UC ±20 %  
10 mA DC ±20 %, 10 mA AC ±20 %  
AC: 5 Hz / DC: 10 Hz  
230 mW / 280 mVA  
Green LED

24 V UC ±20 %  
10 mA DC ±20 %, 10 mA AC ±20 %  
AC: 10 Hz / DC: 30 Hz  
195 mW / 220 mVA  
LED

Load side

Rated switching voltage  
Continuous current  
Inrush current  
Contact type  
Voltage drop at max. load  
Leakage current  
Protective circuit, load side  
Short-circuit-proof

5...48 V DC  
20 mA  
  
1 NO contact (Transistor)  
≤ 1 V  
  
Free-wheeling diode  
No

24 VDC ±20%  
2 A  
  
1 NO contact (Transistor)  
≤ 1.8 V  
  
Varistor  
Yes

General data

Ambient temperature (operational)  
Storage temperature  
Humidity  
Approvals

-25 °C...50 °C  
-40 °C...85 °C  
40 °C / 93 % rel. humidity, no condensation  
CE; CSA; cURus; UKCA

-25 °C...40 °C  
-40 °C...60 °C  
40 °C / 93 % rel. humidity, no condensation  
CE; CSA; cURus; UKCA

Insulation coordinates

Rated voltage  
Impulse withstand voltage  
Dielectric strength for control side - load side  
Dielectric strength to mounting rail  
Clearance and creepage distances for control side - load side  
Overvoltage category  
Pollution degree

300 V  
6 kV (1.2/50 µs)  
1 kV<sub>eff</sub> / 1 s  
4 kV<sub>eff</sub> / 1 Min.  
≥ 5.5 mm  
III  
2

300 V  
6 kV (1.2/50 µs)  
1 kV<sub>eff</sub> / 1 s  
4 kV<sub>eff</sub> / 1 Min.  
≥ 5.5 mm  
III  
2

Dimensions

Clamping range (nominal / min. / max.) mm<sup>2</sup>  
Depth x width x height mm

Tension-clamp connection

1.5 / 0.5 / 1.5  
63.2 / 6.1 / 91  
Further technical data can be found at [eshop.weidmueller.com](http://eshop.weidmueller.com)

Tension-clamp connection

1.5 / 0.5 / 1.5  
63.2 / 6.1 / 91  
Further technical data can be found at [eshop.weidmueller.com](http://eshop.weidmueller.com)

Note

Ordering data

Tension clamp connection

Type	Qty.	Order No.
MCZ O 24VUC	10	8365940000

Type	Qty.	Order No.
MCZ O 24VUC	10	8287730000

Note

Accessories

Note

End plate AP MCZ 1.5: 8389030000  
Accessories and dimensional drawings: refer to the MCZ Accessories page.

End plate AP MCZ 1.5: 8389030000  
Accessories and dimensional drawings: refer to the MCZ Accessories page.

**MCZ O**

- Universal interface between controller and sensor/ actuator
- Tension-clamp connection system
- Plug-in cross-connection
- 6 mm modular wide

**120 V UC**

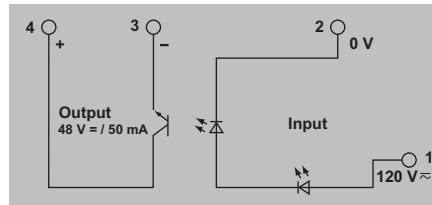
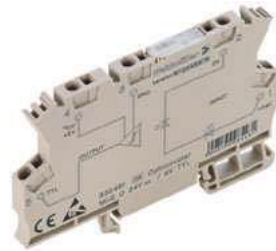

**230 V AC**

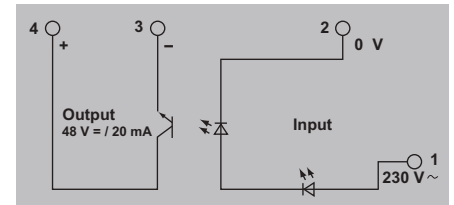

**Technical data**

Control side	
Rated control voltage	
Nominal control current	
Input frequency	
Power rating	
Status indicator	
Protective circuit	
Load side	
Rated switching voltage	
Continuous current	
Inrush current	
Contact type	
Voltage drop at max. load	
Leakage current	
Protective circuit, load side	
Short-circuit-proof	
General data	
Ambient temperature (operational)	
Storage temperature	
Humidity	
Approvals	
Insulation coordinates	
Rated voltage	
Impulse withstand voltage	
Dielectric strength for control side - load side	
Dielectric strength to mounting rail	
Clearance and creepage distances for control side - load side	
Overvoltage category	
Pollution degree	

120 V UC +5 / -15 %
3 mA DC (±10 %), 3 mA AC (±10 %)
AC: 5 Hz / DC: 20 Hz
350 mW / 400 mVA
Green LED
5...48 V DC
50 mA
1 NO contact (Transistor)
1.6 V
≤ 1 mA
Free-wheeling diode
No
-25 °C...40 °C
-40 °C...60 °C
40 °C / 93 % rel. humidity, no condensation
CE; CSA; cURus; UKCA
300 V
6 kV (1.2/50 µs)
1 kV <sub>eff</sub> / 1 s
4 kV <sub>eff</sub> / 1 Min.
≥ 5.5 mm
III
2

230 V AC +5 % / -15 %
10 mA AC ±20 %
AC: 5 Hz duty factor 1:2
2.3 VA
Green LED
5...48 V DC
20 mA
1 NO contact (Transistor)
1.6 V
≤ 1 mA
Free-wheeling diode
No
-25 °C...40 °C
-40 °C...60 °C
40 °C / 93 % rel. humidity, no condensation
CE; CSA; cURus; UKCA
300 V
6 kV (1.2/50 µs)
1 kV <sub>eff</sub> / 1 s
4 kV <sub>eff</sub> / 1 Min.
≥ 5.5 mm
III
2

Dimensions	
Clamping range (nominal / min. / max.)	mm <sup>2</sup>
Depth x width x height	mm
Note	

Tension-clamp connection	
1.5 / 0.5 / 1.5	
63.2 / 6.1 / 91	
Further technical data can be found at <a href="http://eshop.weidmueller.com">eshop.weidmueller.com</a>	

Tension-clamp connection	
1.5 / 0.5 / 1.5	
63.2 / 6.1 / 91	
Further technical data can be found at <a href="http://eshop.weidmueller.com">eshop.weidmueller.com</a>	

**Ordering data**

Tension clamp connection	
Note	

Type	Qty.	Order No.
MCZ O 120VUC	10	8421060000

Type	Qty.	Order No.
MCZ O 230VAC	10	8421380000

**Accessories**

Note
------

End plate AP MCZ 1.5: 8389030000 Accessories and dimensional drawings: refer to the MCZ Accessories page.
--

End plate AP MCZ 1.5: 8389030000 Accessories and dimensional drawings: refer to the MCZ Accessories page.
--

**MCZ 0**

- Universal interface between controller and sensor/ actuator
- Tension-clamp connection system
- Plug-in cross-connection
- 6 mm modular wide

**24 V DC / 5 V TTL**

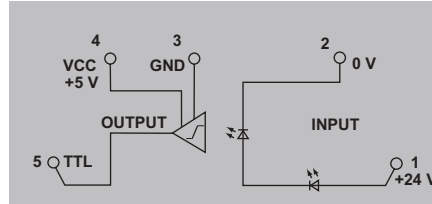

**5 V TTL / 5...48 V DC**

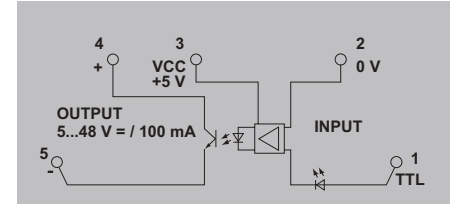

**Technical data**

**Control side**

Rated control voltage  
Nominal control current  
Input frequency  
Power rating  
Status indicator  
Protective circuit

**Load side**

Rated switching voltage  
Continuous current  
Inrush current  
Contact type  
Voltage drop at max. load  
Leakage current  
Protective circuit, load side  
Short-circuit-proof

**General data**

Ambient temperature (operational)  
Storage temperature  
Humidity  
Approvals

**Insulation coordinates**

Rated voltage  
Impulse withstand voltage  
Dielectric strength for control side - load side  
Dielectric strength to mounting rail  
Clearance and creepage distances for control side - load side  
Overvoltage category  
Pollution degree

24 V DC  $\pm 16\%$   
5 mA DC ( $\pm 20\%$ )  
100 kHz  
112 mW  
Green LED

5 V TTL  
8 ma, Fan out = 20 LS-TTL

1 NO contact (TTL)

Diode circuit  
No

-25 °C...40 °C  
-40 °C...60 °C  
40 °C / 93 % rel. humidity, no condensation  
CE; CSA; cURus; UKCA

300 V  
6 kV (1.2/50  $\mu$ s)  
1 kV<sub>eff</sub> / 1 s  
4 kV<sub>eff</sub> / 1 Min.  
 $\geq 5.5$  mm  
III  
2

5 V TTL  
1.65 mA DC  
2.4 kHz  
10 mW  
Green LED

5...48 V DC  
0.1 A

1 NO contact (TTL)  
 $\leq 1.8$  V

Diode circuit  
No

-25 °C...40 °C  
-40 °C...60 °C  
40 °C / 93 % rel. humidity, no condensation  
CE; CSA; cURus; UKCA

300 V  
6 kV (1.2/50  $\mu$ s)  
1 kV<sub>eff</sub> / 1 s  
4 kV<sub>eff</sub> / 1 Min.  
 $\geq 5.5$  mm  
III  
2

**Dimensions**

Clamping range (nominal / min. / max.) mm<sup>2</sup>  
Depth x width x height mm

**Note**

**Tension-clamp connection**

1.5 / 0.5 / 1.5  
63.2 / 6.1 / 91

Further technical data can be found at [eshop.weidmueller.com](http://eshop.weidmueller.com)

**Tension-clamp connection**

1.5 / 0.5 / 1.5  
63.2 / 6.1 / 91

Further technical data can be found at [eshop.weidmueller.com](http://eshop.weidmueller.com)

**Ordering data**

Tension clamp connection

Type	Qty.	Order No.
MCZ 0 24VDC	10	8324610000

Type	Qty.	Order No.
MCZ 0 5VTTL	10	8398940000

**Note**

**Accessories**

**Note**

End plate AP MCZ 1.5: 8389030000  
Accessories and dimensional drawings: refer to the MCZ Accessories page.

End plate AP MCZ 1.5: 8389030000  
Accessories and dimensional drawings: refer to the MCZ Accessories page.

**MCZ O TRAK**

- Component for railway engineering
- Meets the requirements of EN 50155
- Voltage fluctuations of -30% / +25%
- Operating temperature: -25 °C...+70 °C (85 °C / 10 min.) acc. to EN 50155
- Condensation permissible

**24 V DC TRAK**

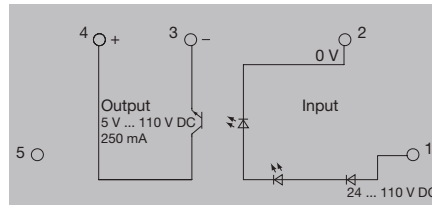
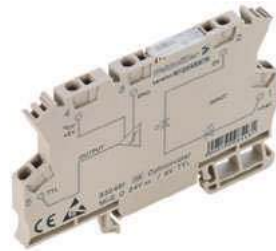

**Technical data**

Control side	
Rated control voltage	24...110 V DC -30 / +25 %
Nominal control current	2.8 mA DC
Input frequency	10 Hz
Power rating	
Status indicator	Green LED
Protective circuit	
Load side	
Rated switching voltage	5...137.5 V DC
Continuous current	250 mA @ 50 °C
Inrush current	
Contact type	1 NO contact (Transistor)
Voltage drop at max. load	≤ 1.7 V
Leakage current	
Protective circuit, load side	Varistor, Free-wheeling diode
Short-circuit-proof	No
General data	
Ambient temperature (operational)	-25 °C...70 °C
Storage temperature	-40 °C...85 °C
Humidity	95 % for 30 days, minimal condensation to EN 50155
Approvals	CE, UKCA
Insulation coordinates	
Rated voltage	300 V
Impulse withstand voltage	6 kV (1.2/50 µs)
Dielectric strength for control side - load side	1 kV <sub>eff</sub> / 1 s
Dielectric strength to mounting rail	4 kV <sub>eff</sub> / 1 Min.
Clearance and creepage distances for control side - load side	≥ 5.5 mm
Overvoltage category	III
Pollution degree	2

Dimensions	
Clamping range (nominal / min. / max.)	mm <sup>2</sup> 1.5 / 0.5 / 1.5
Depth x width x height	mm 63.2 / 6.1 / 91
Note	
Further technical data can be found at <a href="http://eshop.weidmueller.com">eshop.weidmueller.com</a>	

**Dimensions**

Clamping range (nominal / min. / max.)	mm <sup>2</sup>
Depth x width x height	mm

**Note**

**Tension-clamp connection**

1.5 / 0.5 / 1.5
63.2 / 6.1 / 91

Further technical data can be found at [eshop.weidmueller.com](http://eshop.weidmueller.com)

**Ordering data**

Tension clamp connection
--------------------------

Type	Qty.	Order No.
MCZ O TRAK 24.110VDC	10	8820710000

**Note**

**Accessories**

Note
End plate AP MCZ 1.5: 8389030000 Accessories and dimensional drawings: refer to the MCZ Accessories page.

MCZ accessories

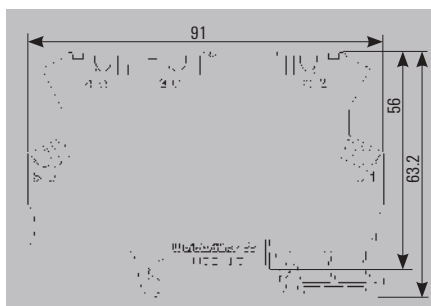

Ordering data

End plate
-----------

Type	Qty.	Order No.
AP MCZ 1.5	50	8389030000

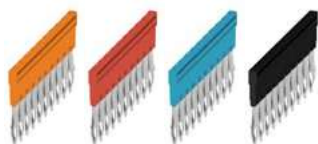

Ordering data

	No. of poles
Plug-in cross-connection, orange	2
Plug-in cross-connection, orange	3
Plug-in cross-connection, orange	4
Plug-in cross-connection, orange	10
Plug-in cross-connection, orange	20
<b>red</b>	
Plug-in cross-connection, red	2
Plug-in cross-connection, red	3
Plug-in cross-connection, red	4
Plug-in cross-connection, red	10
<b>blue</b>	
Plug-in cross-connection, blue	2
Plug-in cross-connection, blue	3
Plug-in cross-connection, blue	4
Plug-in cross-connection, blue	10
<b>black</b>	
Plug-in cross-connection, black	2
Plug-in cross-connection, black	3
Plug-in cross-connection, black	4
Plug-in cross-connection, black	10
Plug-in cross-connection, black	20

Type	Qty.	Order No.
ZQV 4N/2	60	1527930000
ZQV 4N/3	60	1527940000
ZQV 4N/4	60	1527970000
ZQV 4N/10	20	1528090000
ZQV 4N/20	20	2883800000
<b>red</b>		
ZQV 4N/2 RD	60	2460450000
ZQV 4N/3 RD	60	2460810000
ZQV 4N/4 RD	60	2460800000
ZQV 4N/10 RD	20	2460740000
<b>blue</b>		
ZQV 4N/2 BL	60	1528040000
ZQV 4N/3 BL	60	1528080000
ZQV 4N/4 BL	60	1528120000
ZQV 4N/10 BL	20	1528230000
<b>black</b>		
ZQV 4N/2 BK	60	2810840000
ZQV 4N/3 BK	60	2810880000
ZQV 4N/4 BK	60	2810890000
ZQV 4N/10 BK	20	2810830000
ZQV 4N/20 BK	20	2810870000



Ordering data

Terminal markers
Screwdriver
End bracket

Type	Qty.	Order No.
WS 10/6 MC NEUTRAL	600	1828450000
SDS 0.6X3.5X100	1	2749340000
WEW 35/2	50	1061200000

# Application range

<b>Application range</b>	Overview	C.2
	TERMOPTO - Overview	C.4
	MICROOPTO - Overview	C.6
	Special loads	C.8
	Sensor isolation	C.40
	High switching frequencies	C.60
	Signal adaption	C.68
	Timing functions	C.90
	Functional safety	C.112
	Power	C.136
	Accessories	C.150

## Application range

### Relay modules and solid-state relays for specific applications

C

In many industrial applications today, individual, customised solutions and components are used to increase system efficiency and system productivity. These include, for example, protective circuits for greater fail-safe performance, timing relays for adjusting signals, relays for functional safety and space-saving components for use in limited installation spaces.

With our application range we provide you with a customised portfolio to increase your productivity, efficiency and safety in the most diverse fields of application. What's more, we work with you to develop customised solutions, combining the advantages and features of our portfolio with our expertise and consulting services.

We have a wide range of products that combine application-specific designs, the latest technologies and well-proven components to meet all your requirements.

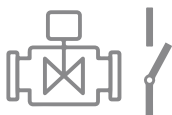

#### Special loads

Particularly durable solid-state relays and relay modules for low-wear switching of high inductances and inrush currents – reliable, safe, and space-saving.



#### Timing functions

Reliable timing relays for delaying, extending, or clocking signals as well as for error compensation at high cycle rates or short pulses - mainly in factory and building automation.



#### Sensor isolation

Space-saving, reliable and fast switching solid-state relays and relay modules with gold contacts for isolating sensor signals from the field. Specially designed for reliable switching of small loads.

## SIL

#### Functional safety

Standard-compliant safety relays for switching signals in safety-relevant systems and processes. Optimum fault detection and prevention for the protection of people and materials.



#### High switching frequencies

Specially developed solid-state relays and optocouplers for reliable and delay-free switching of extremely fast signals up to 550 kHz. Ideally suited e.g. for machines with high speeds.



#### Power

Special relays for switching high industrial loads. Power solid-state relays (PSSR) up to 30 A and small contactors (PWR) up to 30 A to cover different fields of application.



#### Signal adaptation

Space-saving solid-state relays and relay modules for adapting digital signals from external systems to the existing system environment. Cost-efficient use without PLC input cards.



Special loads



Sensor isolation



Signal adaption

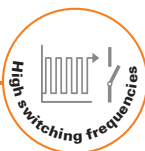

High switching frequencies

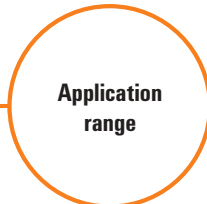

Application range

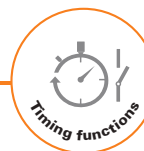

Timing functions



SIL  
Functional safety

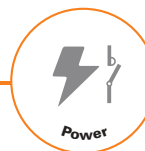

Power

# TERMOPTO

## Wear-free potential isolation in terminal block design

**C** In many applications, it is essential that relays for potential isolation and signal adjustment perform their tasks reliably and permanently. Instead of wear-prone electromechanical solutions, maintenance-free relays with integrated potential isolation are increasingly being used.

TERMOPTO solid-state relays in terminal block design are the perfect solution for the simple and reliable decoupling of digital signals. Besides their particularly compact design, they are distinguished by their PUSH IN connection system, plug-in cross-connections and an optimal price/performance ratio.

With TERMOPTO solid-state relays, you save space in the panel, reduce your service costs and sustainably increase plant availability. You also reduce the complexity of the required accessories as you can use components from the Weidmüller portfolio, from cross-connectors to markers.

**Well-designed all round**

The LED status indicator provides information about the switching status. Suitable accessories from cross-connectors to continuous marking solutions can be procured from the Weidmüller portfolio.

**Wide voltage range**

Ten input voltages from 5 V DC to 230 V AC, a particularly compact multi-voltage input for 48 to 60 V DC and a variant for input voltages from 48 to 60 V AC ensure a high level of flexibility.

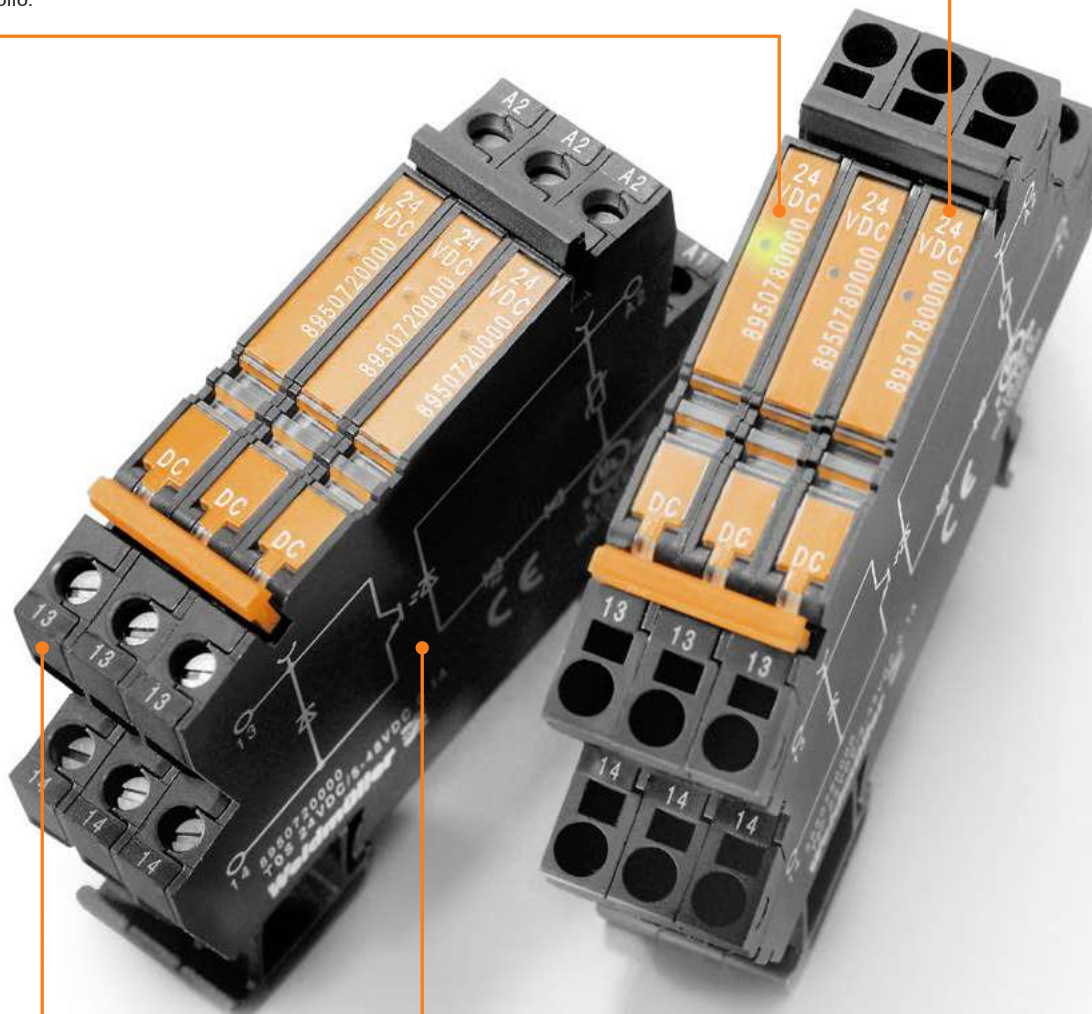
**Permanently reliable**

The wear-free solid-state technology with comprehensive protective suppressor circuit for inputs and outputs makes TERMOPTO particularly long-lasting and reliable.

**Extremely compact**

The compact design with a width of just 6.1 mm reduces the space required in the panel by more than 80% compared to conventional solid-state relays.

# MICROOPTO

## Compact and powerful solid-state relays in terminal block design

**C** Saving space in the panel is becoming more and more important, and requires increasingly compact components. With the compact and powerful MICROOPTO solid-state relays, you benefit from our decades of experience in manufacturing products in terminal block design.

The MICROOPTO family comprises high-quality solid-state relays for application-specific problem solving and delivers high performance in a width of just 6.1 mm. The wide range of accessories from plug-in cross-connections to end-to-end marking solutions makes it particularly versatile. Thanks to international approvals, they can be used worldwide. Reliable function is ensured by the integrated protective suppressor circuit for inputs and outputs.

The wide MICROOPTO portfolio includes a range of solutions for special loads. For example, for inductive loads up to 10 A at 24 V DC or for DC loads up to 300 V. In addition, there are solutions for decoupling 5 V TTL inputs and outputs, for frequencies up to 550 kHz, as well as the 1 CO contact version for inverting signals.

**MICROOPTO for signal adjustment**

Available in special versions for the transmission of 5 V TTL signals to PLC systems and industrial computers – or equipped with 1 CO contact output for inverting signals.

**MICROOPTO for 10 A and ACTOR (2A)**

Powerful solid-state relays with a particularly short-circuit-proof output. The equipment includes a status and error LED in the output as well as an auxiliary contact for reporting short circuits.

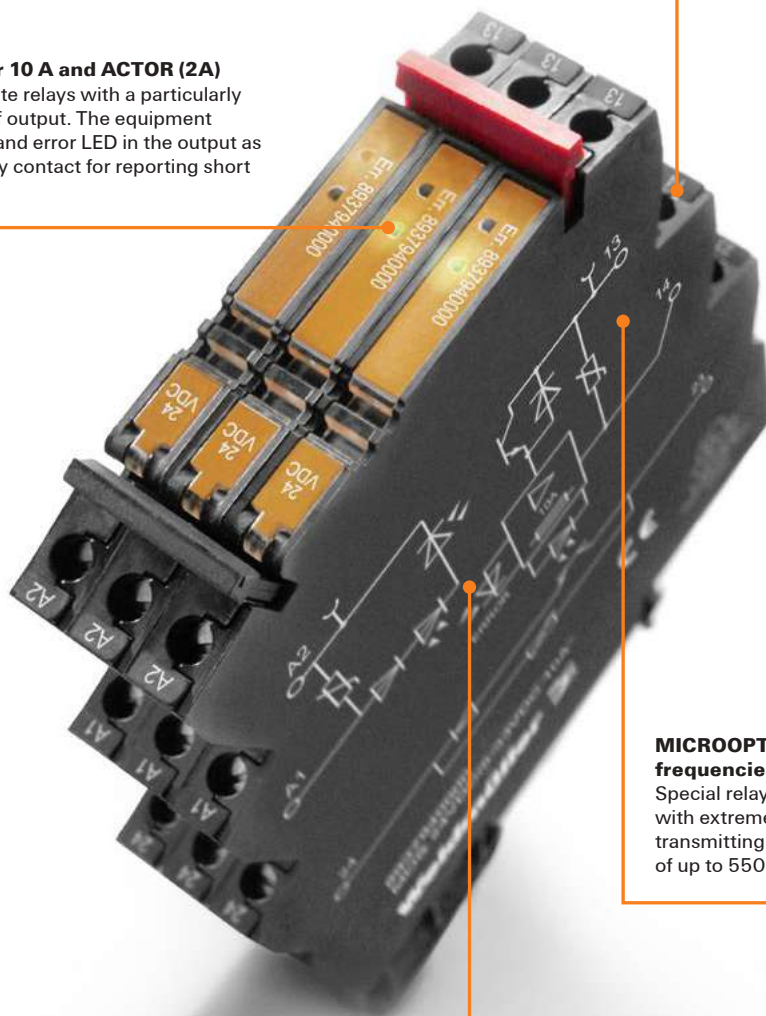

**MICROOPTO for high switching frequencies**

Special relays for reliable signal decoupling with extremely fast switching operations or for transmitting signals with switching frequencies of up to 550 kHz.

**MICROOPTO for 300 V DC**

Special solid-state relays for DC voltages up to 300 VDC, 1 A. The integrated protective suppressor circuit also enables the switching of inductive loads with high DC voltages.

## Special loads

### Reliably switch or monitor inductive, capacitive and high loads

If special loads such as inductivities or high inrush currents are to be switched or monitored safely and reliably, you need individually tailored relay modules and solid-state relays. These customised solutions extend the service life of the switching element and, what's more, they can be installed in the panel in a space-saving manner thanks to optimised connection options.

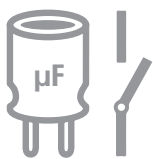

#### Capacitive loads

Many loads with capacitive load components are now concealed in upstream pre-circuits, e.g. in solenoid valves, contactors or power supplies for LED lighting. These pre-circuits can contain capacitors that generate high inrush current peaks of up to 150 A. Such current peaks can lead to welding of the output contacts or destroy the output. To avoid this, special relay modules and solid-state relays from our portfolio are used.

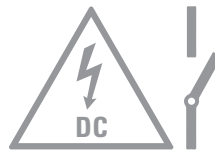

#### High DC voltages

Standard relay modules can only switch relatively low DC currents because they lack the zero crossing to extinguish the light arc. Their maximum DC current value also depends on the switching voltage as well as the design conditions such as contact gap and contact opening speed. Our power relays for switching high DC loads have a built-in blowout magnet and a large contact gap to significantly minimise contact wear.



#### Inductive loads

Switching inductive loads, e.g. solenoid valves, can cause electric arcs with voltage peaks of up to several thousand volts. They are caused during the switching process by the energy stored in the coil and can destroy the contact through material evaporation and material migration. With high DC voltage and a continuous light arc, the relay can even fail during the first switching cycle. In order to suppress the formation of electric arcs, you need to use an external protective suppressor circuit. We offer special products for switching inductive loads, which have a special overload or protective suppressor circuit for the output, for example.



#### Wiring-optimised variants

The optimisation of wiring time and space requirements is becoming increasingly important. Our versions with snap-on PE foot allow for fast wiring of actuators where a PE contact is required. This means that no additional PE terminal is required in the panel. Our 1 NO contact variants allow the use of a connection on the relay socket for wiring the negative or neutral conductor potential. Therefore, the negative potential is bridged to the designated connection with the aid of a power-feed terminal in order to wire the actuators directly – without an additional terminal for the negative potential.



Visit our website for more information  
[www.weidmueller.com/si](http://www.weidmueller.com/si)

## Special loads – MICROOPTO

### For switching valves up to 24 VDC 10 A

- Width only 6 mm
- Plug-in cross-connector
- For mounting on TS 35
- Status display and error signaling contact with an error in the output

### 24 V DC / 5-33 V DC 10 A

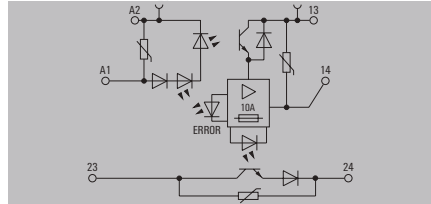

#### Technical data

Control side	
Rated control voltage	24 V DC ±20 %
Power rating	400 mW
Input frequency	50 Hz
Status indicator	Green LED
Protective circuit	Varistor, Reverse polarity protection
Load side	
Solid-state type	POWER MOS-FET
Rated switching voltage	5...33 V DC
Continuous current	10 A
Voltage drop at max. load	approx. 100 mV
Leakage current	<1 mA
Short-circuit-proof / Protective circuit, load side	Yes (limited for 4 h / current limitation external <200 A) / Current sensor, Varistor, Free-wheeling diode
Switch-on delay / Switch-off delay	typ. 250 µs / typical. 700 µs
Pulse load, max. current	≤ 11 A (≤ 200 µs)
General data	
Ambient temperature (operational)	-25 °C...60 °C
Storage temperature	-40 °C...60 °C
UL 94 flammability rating	V-0
Humidity	5 - 93% rel. humidity, Tu = 40°C, no condensation
Approvals	CE; cULus; DETNORVER; UKCA
Insulation coordinates	
Rated voltage	300 V
Impulse withstand voltage	4 kV (1.2/50 µs)
Dielectric strength for control side - load side	3 kV <sub>eff</sub> / 1 Min.
Dielectric strength to mounting rail	4 kV <sub>eff</sub> / 1 Min.
Clearance and creepage distances for control side - load side	> 3 mm
Overvoltage category	III
Pollution degree	2
Dimensions	
Clamping range (nominal / min. / max.)	mm <sup>2</sup>
Depth x width x height	mm
Note	
Suppressor circuitry for inductive loads, 10 cm installation clearance to inductive switching devices.	

#### Ordering data

Screw connection
Note

#### Accessories

Note
------

Type		
MOS 24VDC/5-33VDC 10A	Qty.	Order No.
	1	8937940000
Screw connection		
2.5 / 0.5 / 4		
97.8 / 6.1 / 88.1		
Accessories and dimensioned drawings: refer to the MICROOPTO Accessories page.		

The **MICROOPTO SOLENOID** solid-state relay is used specifically as a switching amplifier for actuators up to 24 V DC and 10 A with inductive loads such as solenoid valves and contactors.

A potential-free signalling contact transmits errors, such as short circuits, to the controller.

The **MICROOPTO SOLENOID** solid-state relay is short-circuit-proof and protected against power-related transients and voltage peaks by extensive protective circuits. The closed housing also offers a high level of protection against contact.

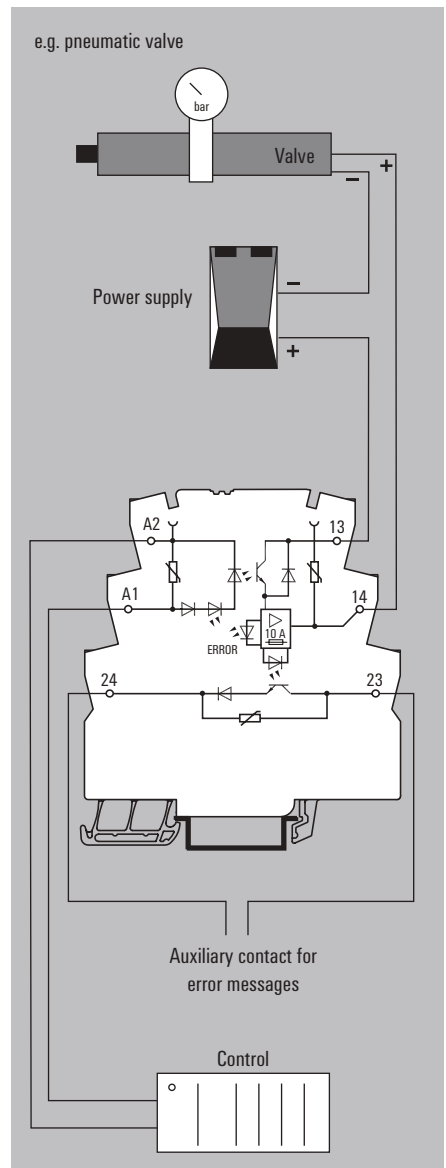
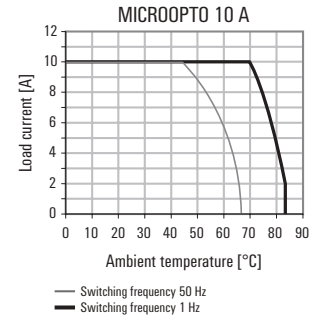

**For DC loads up to 300 V DC and 1 A**

- Only 6 mm modular width
- Plug-in cross-connection
- Power Boost: 20 A / 20 ms, 5 A / 1 sec

**12...300 V DC 1 A**

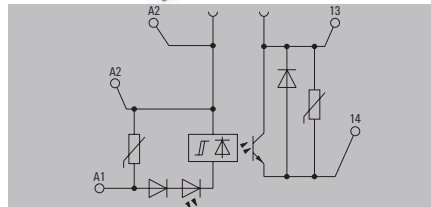

The solid-state relay **MICROOPTO 300 V DC** has been developed as a switching amplifier for high inductive loads up to 300 V DC and 1 A in motor brakes and contactors.

A power boost in the load circuit compensates transient overloads (20 A for 20 ms / 5 A for 1 s) such as making or breaking spikes. Additional protective circuits counter higher overloads.

**derating curve**

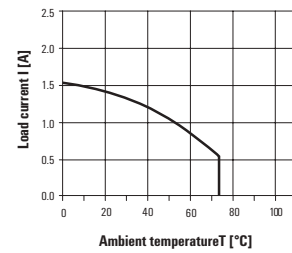

**Technical data**

Control side	
Rated control voltage	24 V DC ±20 %
Power rating	0.36 W
Input frequency	50...60Hz
Status indicator	Green LED
Protective circuit	Varistor, Reverse polarity protection

Load side	
Solid-state type	POWER MOS-FET
Rated switching voltage	12...300 V DC
Continuous current	1 A
Voltage drop at max. load	≤ 0.4 V
Leakage current	<1 µA
Short-circuit-proof / Protective circuit, load side	No / Varistor, Free-wheeling diode

Switch-on delay / Switch-off delay	<18 µs / <1 ms
Pulse load, max. current	27 A (10 ms)

General data	
Ambient temperature (operational)	-25 °C...60 °C
Storage temperature	-40 °C...80 °C
UL 94 flammability rating	V-0
Humidity	5-95% relative humidity, T <sub>a</sub> = 55°C, without condensation
Approvals	CE; cULus; DETNORVER; UKCA

Insulation coordinates	
Rated voltage	300 V
Impulse withstand voltage	2.5 kV (1.2/50 µs)
Dielectric strength for control side - load side	3 kV <sub>eff</sub> / 1 Min.
Dielectric strength to mounting rail	4 kV <sub>eff</sub> / 1 Min.
Clearance and creepage distances for control side - load side	> 3 mm
Overvoltage category	III
Pollution degree	2

Dimensions	
Clamping range (nominal / min. / max.)	mm <sup>2</sup>
Depth x width x height	mm

**Note**

Rated control voltage	24 V DC ±20 %
Power rating	0.36 W
Input frequency	50...60Hz
Status indicator	Green LED
Protective circuit	Varistor, Reverse polarity protection

POWER MOS-FET	
Rated switching voltage	12...300 V DC
Continuous current	1 A
Voltage drop at max. load	≤ 0.4 V
Leakage current	<1 µA
Short-circuit-proof / Protective circuit, load side	No / Varistor, Free-wheeling diode

Switch-on delay / Switch-off delay	<18 µs / <1 ms
Pulse load, max. current	27 A (10 ms)

General data	
Ambient temperature (operational)	-25 °C...60 °C
Storage temperature	-40 °C...80 °C
UL 94 flammability rating	V-0
Humidity	5-95% relative humidity, T <sub>a</sub> = 55°C, without condensation
Approvals	CE; cULus; DETNORVER; UKCA

Insulation coordinates	
Rated voltage	300 V
Impulse withstand voltage	2.5 kV (1.2/50 µs)
Dielectric strength for control side - load side	3 kV <sub>eff</sub> / 1 Min.
Dielectric strength to mounting rail	4 kV <sub>eff</sub> / 1 Min.
Clearance and creepage distances for control side - load side	> 3 mm
Overvoltage category	III
Pollution degree	2

Screw connection		
Clamping range (nominal / min. / max.)	mm <sup>2</sup>	
Depth x width x height	mm	

**Note**

**Ordering data**

Screw connection
------------------

**Note**

Type	Qty.	Order No.
MOS 24VDC/12-300VDC 1A	1	8937830000

**Accessories**

**Note**

Accessories and dimensioned drawings: refer to the MICROOPTO Accessories page.

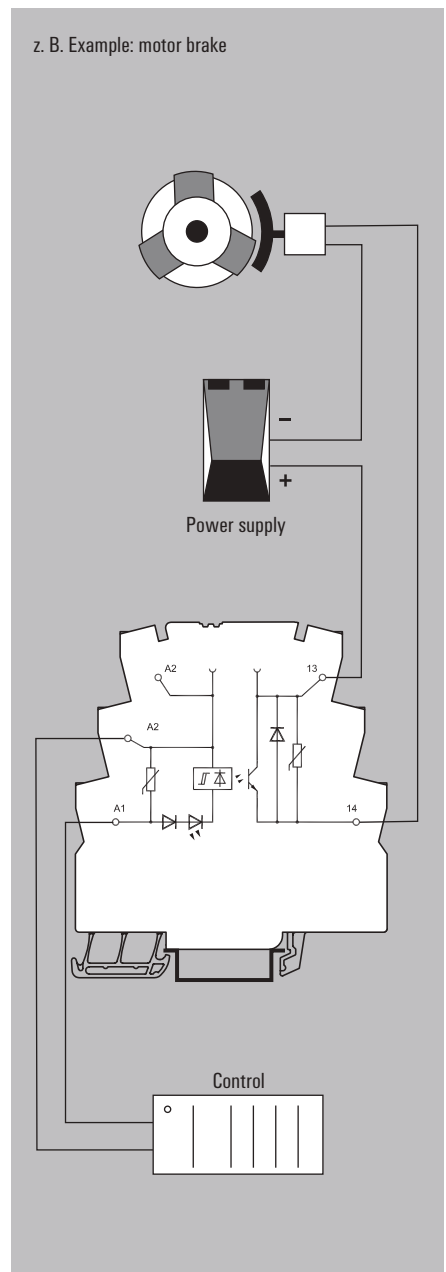

**For direct connection of actuators up to 24 V DC 2 A**

- Only 6 mm modular width
- Plug-in cross-connection
- PE connection direct to mounting rail
- Status display when error in output

**8...30 V DC 2 A**

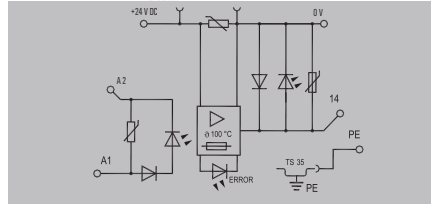

The solid-state relay **MICROOPTO ACTOR** has been specifically designed as a switching amplifier for actuators up to 24 V DC and 2 A with inductive loads such as solenoid valves and contactors. 3-wire actuators can be connected directly to the module.

This is short-circuit proof and protected against application-related transients and spikes by extensive protective circuitry.

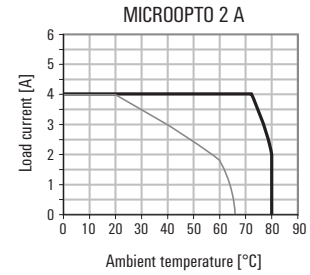

**Technical data**

**Control side**

- Rated control voltage
- Power rating
- Input frequency
- Status indicator
- Protective circuit

**Load side**

- Solid-state type
- Rated switching voltage
- Continuous current
- Voltage drop at max. load
- Leakage current
- Load side status indicator

- Short-circuit-proof / Protective circuit, load side
- Switch-on delay / Switch-off delay
- Pulse load, max. current

**General data**

- Ambient temperature (operational)
- Storage temperature
- UL 94 flammability rating
- Humidity
- Approvals

**Insulation coordinates**

- Rated voltage
- Impulse withstand voltage
- Dielectric strength for control side - load side
- Dielectric strength to mounting rail
- Clearance and creepage distances for control side - load side
- Overvoltage category
- Pollution degree

**Dimensions**

- Clamping range (nominal / min. / max.) mm<sup>2</sup>
- Depth x width x height mm

**Note**

**Ordering data**

Screw connection

**Note**

**Accessories**

**Note**

**24 V DC ±20 %**

- ≤ 170 mW
- 125 Hz
- No
- Varistor, Reverse polarity protection

**Intelligent POWER MOS-FET**

- 8...30 V DC
- 2 A
- ≤ 50 mV
- <10 µA
- LED green, output switched, LED red, short-circuit / overload at the output
- Yes (thermal cut-out) / Varistor, Free-wheeling diode
- 0.1 ms / <0.5 ms

**-25 °C...60 °C**

- 40 °C...80 °C
- V-0
- 5-95% relative humidity, T<sub>v</sub> = 55 °C, without condensation
- CE; cULus; DETNORVER; UKCA

**30 V**

- 500 V (1,2/50 µ)
- 350 V<sub>eff</sub> / 1 min.
- 350 V<sub>eff</sub> / 1 min.

**III**

**2**

**Screw connection**

- 2.5 / 0.5 / 4
- 97 / 6.1 / 88.1

Type	Qty.	Order No.
MOS 24VDC/8-30VDC 2A	1	8937970000

Accessories and dimensioned drawings: refer to the MICROOPTO Accessories page.

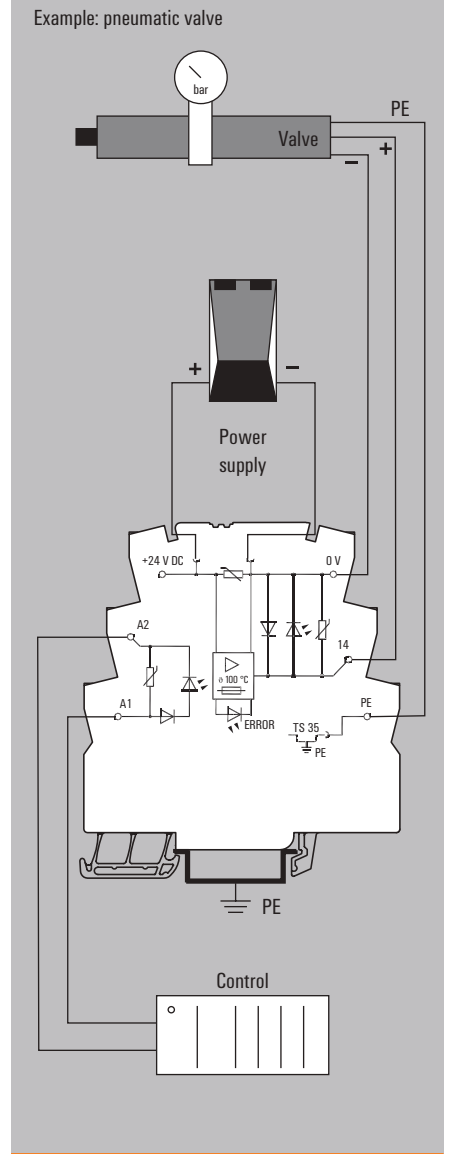

**For direct connection of actuators  
up to 24 V DC 2 A**

- Width only 6 mm
- Plug-in cross-connector
- Status display when error in output

**24 V DC / 8-30 V DC 2 A E**



The solid-state relay **MICROOPTO ACTOR** has been specifically designed as a switching amplifier for actuators up to 24 V DC and 2 A with inductive loads such as solenoid valves and contactors. 2-wire actuators can be connected directly to the module. This is short-circuit proof and protected against application-related transients and spikes by extensive protective circuitry.

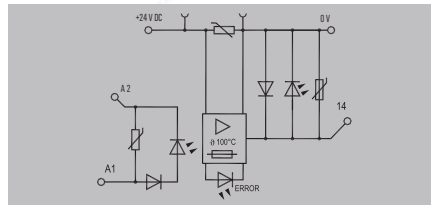

**Technical data**

Control side	
Rated control voltage	24 V DC ±20 %
Power rating	≤ 170 mW
Input frequency	10 Hz
Status indicator	No
Protective circuit	Varistor, Reverse polarity protection
Load side	
Solid-state type	Intelligent POWER MOS-FET
Rated switching voltage	8...30 V DC
Continuous current	2 A
Voltage drop at max. load	≤ 50 mV
Leakage current	<10 µA
Load side status indicator	LED green, output switched, LED red, short-circuit /overload at the output
Short-circuit-proof / Protective circuit, load side	Yes (thermal cut-out) / Varistor, Free-wheeling diode
Switch-on delay / Switch-off delay	0.1 ms / <0.5 ms
Pulse load, max. current	
General data	
Ambient temperature (operational)	-25 °C...60 °C
Storage temperature	-40 °C...80 °C
UL 94 flammability rating	V-0
Humidity	5-95% relative humidity, T <sub>a</sub> = 55°C, without condensation
Approvals	CE, UKCA
Insulation coordinates	
Rated voltage	30 V
Impulse withstand voltage	500 V (1,2/50 µ)
Dielectric strength for control side - load side	350 V <sub>eff</sub> / 1 min.
Dielectric strength to mounting rail	350 V <sub>eff</sub> / 1 min.
Clearance and creepage distances for control side - load side	
Overvoltage category	III
Pollution degree	2
Dimensions	
Clamping range (nominal / min. / max.)	mm <sup>2</sup>
Depth x width x height	mm
Note	

Screw connection		
Type	Qty.	Order No.
MOS 24VDC/8-30VDC 2A E	10	1283230000

**Ordering data**

Screw connection	
Note	

**Accessories**

Note	
Accessories and dimensional drawings: refer to the MICROOPTO Accessories page	

**Example: pneumatic valve**

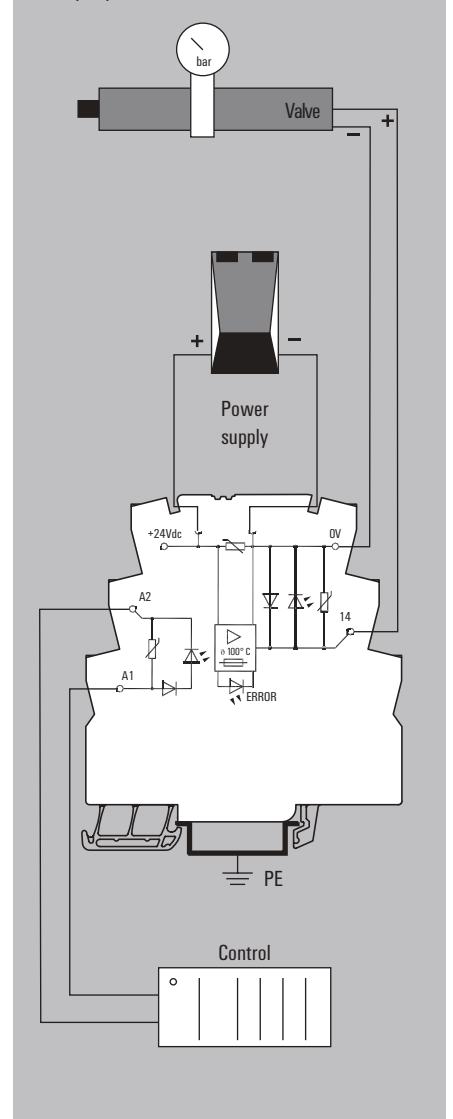

**Solid-state relay, 3...33 V DC / 4 A**

**Output versions**

- Space-saving 6.1 mm width
- Plug-in cross-connections
- Screw and PUSH IN wire connection
- Enclosed design



**24 V DC**

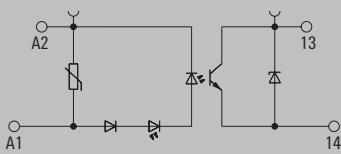

**Technical data**

Load side	
Rated switching voltage	3...33 V DC
Continuous current	4 A
Inrush current	
Solid-state type	MOS-FET
Voltage drop at max. load	90 mV
Leakage current	<10 µA
Protective circuit, load side	Varistor
Short-circuit-proof / Protective circuit, load side	No / Varistor
General data	
Ambient temperature (operational)	-20 °C...60 °C
Storage temperature	-40 °C...80 °C
Humidity	5-95% relative humidity, T <sub>0</sub> = 40°C, without condensation
Approvals	CE, cULus
Insulation coordinates	
Rated voltage	300 V
Impulse withstand voltage	4 kV (1.2/50 µs)
Dielectric strength for control side - load side	1.2 kV <sub>eff</sub> / 1 min.
Dielectric strength to mounting rail	
Clearance and creepage distances for control side - load side	> 3 mm
Overvoltage category	III
Pollution degree	2

Dimensions	Screw connection	PUSH IN connection
Clamping range (nominal / min. / max.)	mm <sup>2</sup> 2.5 / 0.5 / 4	1.5 / 0.5 / 2.5
Depth x width x height	mm 55 / 6.1 / 74.4	55 / 6.1 / 79.4

**Note** Accessories and dimensioned drawings: see accessories page from TERMOPTO

**Ordering data**

**Control side**

	24 V DC
Rated control voltage	24 V DC ±20 %
Nominal control current	7 mA DC
Power rating	≤ 170 mW

max. switching frequency (DC control voltage)	10 Hz
max. switching frequency (AC control voltage)	
Status indicator	Green LED
Protective circuit	Varistor, Reverse polarity protection

**Ordering data**

Screw connection	Type	TOS 24VDC/24VDC 4A
	Order No.	<b>1275100000</b>
PUSH IN connection	Type	TOP 24VDC/24VDC 4A
	Order No.	<b>1254880000</b>

**Note**



1 NO contact, inrush power HC

- Space-saving, 12.8 mm wide
- 16 A AgSnO contact
- Internal cross-connection of the output terminals
- Especially for capacitive loads
- PUSH IN and screw connection
- Multi-voltage input: 24...230 V UC in one module

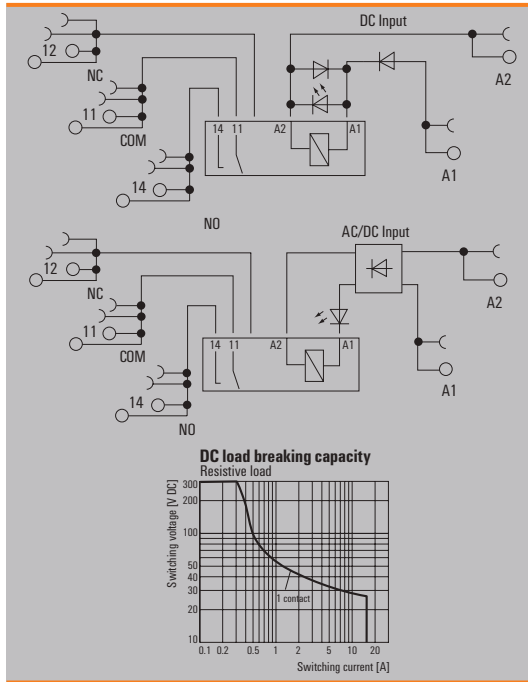
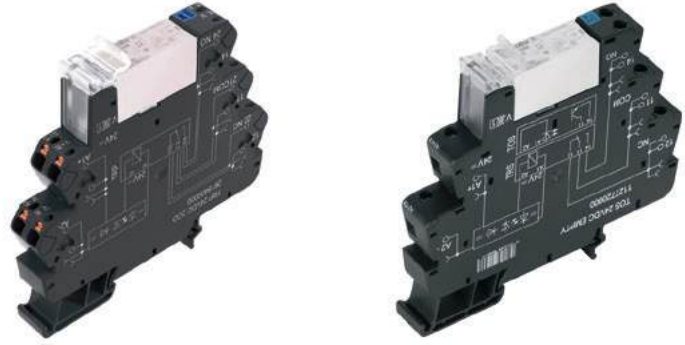

Technical data

Load side	
Rated switching voltage / Continuous current	250 V AC / 16 A
Max. switching voltage, AC	250 V
Inrush current	80 A / 20 ms
Min. switching power	1 W
Contact type	1 NO contact (AgSnO)
Mechanical service life	10 x 10 <sup>6</sup> switching cycles
Max. switching frequency at rated load	0.1 Hz
General data	
Ambient temperature (operational)	-40 °C...60 °C
Storage temperature	-40 °C...85 °C
Humidity	5-95% relative humidity, T <sub>0</sub> = 40°C, without condensation
Approvals	CE; cULus; DETNORVER; UKCA
Insulation coordinates	
Rated voltage	300 V
Impulse withstand voltage	
Dielectric strength for control side - load side	3.51 kV <sub>eff</sub> / 1 min.
Dielectric strength of neighbouring contacts	
Dielectric strength to mounting rail	3.51 kV <sub>eff</sub> / 1 min.
Clearance and creepage distances for control side - load side	≥ 6 mm
Overvoltage category	III
Pollution degree	2
Dimensions	
Clamping range (nominal / min. / max.)	mm <sup>2</sup> 1.5 / 0.14 / 2.5
Depth x width x height	mm 87.8 / 12.8 / 89.4
Note	
Accessories and dimensional drawings: refer to the TERMSERIES Accessories page. Further approvals and technical data can be found at <a href="http://eshop.weidmueller.com">eshop.weidmueller.com</a>	

Ordering data

Control side	24 V DC	24 - 230 V UC
Rated control voltage	24 V DC ± 20 %	24...230 V UC ± 10 %
Rated current AC / DC	/ 22.0 mA	23.5 mA @ 24 V AC, 4.5 mA @ 230 V AC / 22.5 mA @ 24 V DC, 2.0 mA @ 230 V DC
Power rating	530 mW	540 mW @ 24 V DC, 460 mW @ 230 V DC, 565 mVA @ 24 V AC, 1.0 VA @ 230 V AC
Status indicator	Green LED	Green LED
Protective circuit	Free-wheeling diode, Reverse polarity protection	Rectifier
Approvals	CE; cULus; DETNORVER; UKCA	CE; cULus; DETNORVER; UKCA

Ordering data		
PUSH IN connection Type	TRP 24VDC 1NO HC	TRP 24-230VUC 1NO HC ED2
Order No.	<b>2618090000</b>	<b>2663130000</b>
Screw connection Type	TRS 24VDC 1NO HC	TRS 24-230VUC 1NO HC ED2
Order No.	<b>1479780000</b>	<b>2662970000</b>
Note		

**1 NO contact, inrush power HCP**

- Space-saving, only 12.8 mm wide
- 16 A AgSnO contact + leading tungsten contact
- Internal cross-connection of the output terminals
- Especially for capacitive loads
- PUSH IN and screw connection
- Multi-voltage input: 24...230 V UC in one module

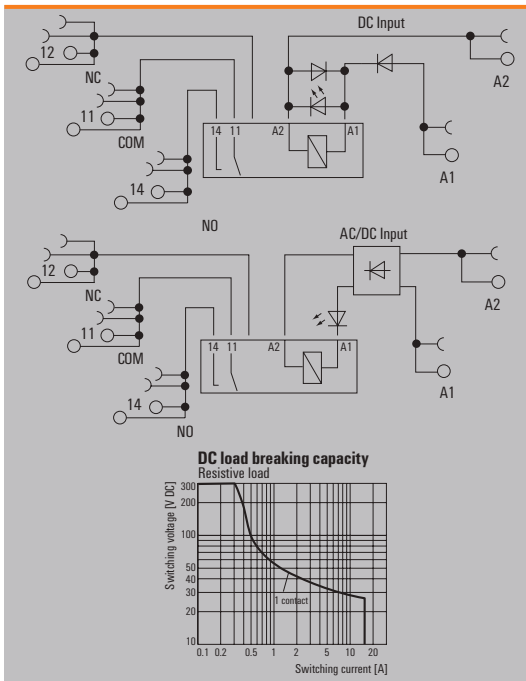
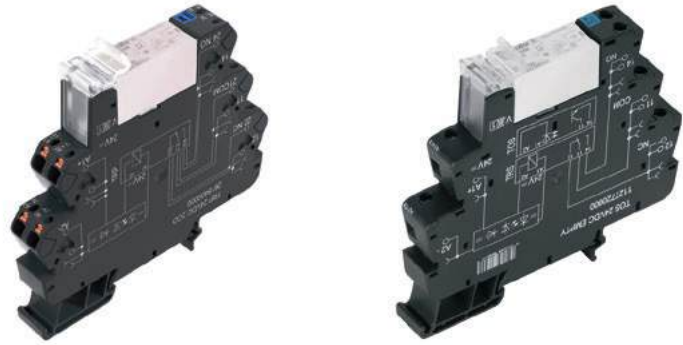

**Technical data**

Load side		
Rated switching voltage / Continuous current	250 V AC / 16 A	
Max. switching voltage, AC	250 V	
Inrush current	165 A / 20 ms, 800 A / 200 µs	
Min. switching power	1 W	
Contact type	1 NO contact (AgSnO + W)	
Mechanical service life	5 x 10 <sup>6</sup> switching cycles	
Max. switching frequency at rated load	0.1 Hz	
General data		
Ambient temperature (operational)	-40 °C...60 °C	
Storage temperature	-40 °C...85 °C	
Humidity	5-95% relative humidity, T <sub>0</sub> = 40°C, without condensation	
Approvals	CE; cULus; DETNORVER; UKCA	
Insulation coordinates		
Rated voltage	300 V	
Impulse withstand voltage	6 kV (1.2/50 µs)	
Dielectric strength for control side - load side	1.2 kV <sub>eff</sub> / 5 s	
Dielectric strength of neighbouring contacts		
Dielectric strength to mounting rail	4 kV <sub>eff</sub> / 1 Min.	
Clearance and creepage distances for control side - load side	≥ 6 mm	
Overvoltage category	III	
Pollution degree	2	
Dimensions		
	PUSH IN	Screw connection
Clamping range (nominal / min. / max.)	mm <sup>2</sup> 1.5 / 0.14 / 2.5	1.5 / 0.14 / 2.5
Depth x width x height	mm 87.8 / 12.8 / 89.4	87.8 / 12.8 / 89.6
Note	Accessories and dimensional drawings: refer to the TERMSERIES Accessories page. Further approvals and technical data can be found at <a href="http://eshop.weidmueller.com">eshop.weidmueller.com</a>	

**Ordering data**

Control side	24 V DC	24 V - 230 V UC
Rated control voltage	24 V DC ± 20 %	24...230 V UC ± 10 %
Rated current AC / DC	/ 22.0 mA	23.5 mA @ 24 V AC, 4.5 mA @ 230 V AC / 22.5 mA @ 24 V DC, 2.0 mA @ 230 V DC
Power rating	530 mW	540 mW @ 24 V DC, 460 mW @ 230 V DC, 565 mVA @ 24 V AC, 1.0 VA @ 230 V AC
Status indicator	Green LED	Green LED
Protective circuit	Free-wheeling diode, Reverse polarity protection	Rectifier
Approvals	CE; cULus; DETNORVER; UKCA	CE; cULus; DETNORVER; UKCA

Ordering data		
PUSH IN connection	Type TRP 24VDC 1NO HCP	TRP 24-230VUC 1NO HCP ED2
Order No.	<b>2617930000</b>	<b>2663140000</b>
Screw connection	Type TRS 24VDC 1NO HCP	TRS 24-230VUC 1NO HCP ED2
Order No.	<b>1479810000</b>	<b>2662980000</b>
Note		

1 NO contact (actuator)

- Space-saving, only 6.4 mm wide
  - AgNi contact
  - PUSH IN and screw connection
  - 24 V DC actuator version:
- Bridgeable, potential-free connection in the output (DC)
- Optional with test button

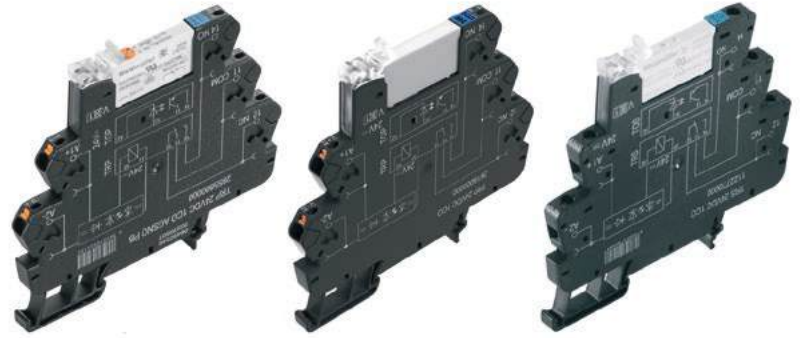

Technical data

Load side		
Rated switching voltage / Continuous current	250 V AC / 6 A	
Max. switching voltage, AC	250 V	
Inrush current	20 A / 20 ms	
Min. switching power	1 mA @ 24 V, 10 mA @ 12 V, 100 mA @ 5 V	
Contact type	1 NO contact (AgNi)	
Mechanical service life	5 x 10 <sup>6</sup> switching cycles	
Max. switching frequency at rated load	0.1 Hz	
General data		
Ambient temperature (operational)	-40 °C...60 °C	
Storage temperature	-40 °C...85 °C	
Humidity	5-95% relative humidity, T <sub>90</sub> = 40°C, without condensation	
Approvals	CE; cULus; DETNORVER; UKCA	
Insulation coordinates		
Rated voltage	300 V	
Impulse withstand voltage	6 kV (1.2/50 µs)	
Dielectric strength for control side - load side	4 kV <sub>eff</sub> / 1 Min.	
Dielectric strength of neighbouring contacts		
Dielectric strength to mounting rail	4 kV <sub>eff</sub> / 1 Min.	
Clearance and creepage distances for control side - load side	≥ 6 mm	
Overvoltage category	III	
Pollution degree	2	
Dimensions		
	<b>PUSH IN</b>	<b>Screw connection</b>
Clamping range (nominal / min. / max.)	mm <sup>2</sup> 1.5 / 0.14 / 2.5	1.5 / 0.14 / 2.5
Depth x width x height	mm 87.8 / 6.4 / 89.4	87.8 / 6.4 / 89.6
Note		
Accessories and dimensional drawings: refer to the TERMSERIES Accessories page. Further approvals and technical data can be found at <a href="http://eshop.weidmueller.com">eshop.weidmueller.com</a>		

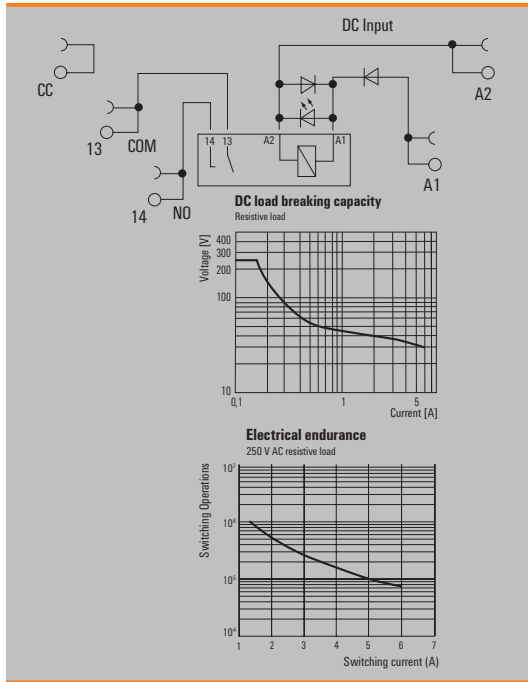

Ordering data

Control side	24 V DC ACT	24VDC ACT PB
Rated control voltage	24 V DC ± 20 %	24 V DC ± 20 %
Rated current AC / DC	/ 11.5 mA	/ 11.5 mA
Power rating	280 mW	280 mW
Status indicator	Green LED	Green LED
Protective circuit	Free-wheeling diode, Reverse polarity protection	Free-wheeling diode, Reverse polarity protection

Ordering data			
PUSH IN connection	Type	TRP 24VDC ACT	TRP 24VDC ACT PB
	Order No.	<b>2618230000</b>	<b>2855840000</b>
Screw connection	Type	TRS 24VDC ACT	TRS 24VDC ACT PB
	Order No.	<b>1381900000</b>	<b>2855850000</b>
Note			

**Solid-state relay, 3...33 V DC / 2 A actuator versions**

- Space-saving, only 6.4 mm wide
- AgNi contact
- PUSH IN and screw connection
- 24 V DC actuator version:  
Bridgeable, potential-free connection in the output (CC)

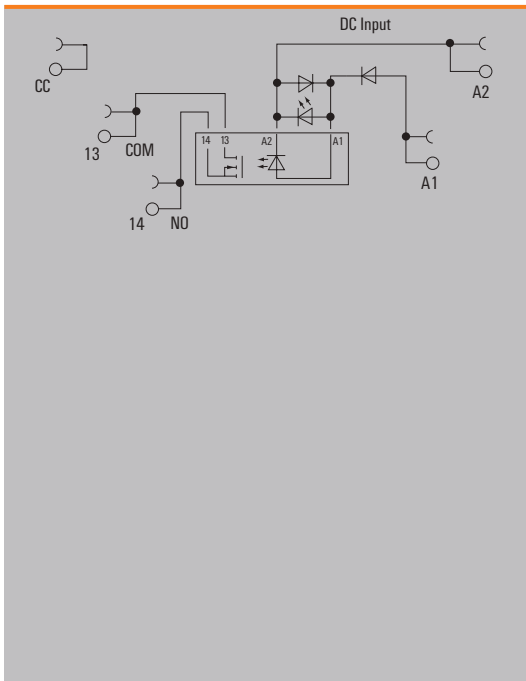

**Technical data**

Load side	
Rated switching voltage	3...33 V DC
Continuous current	2 A
Inrush current	15 A / 10 ms
Contact type	1 NO contact (MOS-FET)
Voltage drop at max. load	≤ 120 mV
Leakage current	<10 µA
Short-circuit-proof / Protective circuit, load side	No / Free-wheeling diode
General data	
Ambient temperature (operational)	-20 °C...60 °C
Storage temperature	-40 °C...70 °C
Humidity	5-95% relative humidity, T <sub>90</sub> = 40°C, without condensation
Approvals	CE; cULus; DETNORVER; UKCA
Insulation coordinates	
Rated voltage	300 V
Impulse withstand voltage	6 kV (1.2/50 µs)
Dielectric strength for control side - load side	2.5 kV <sub>eff</sub>
Dielectric strength to mounting rail	4 kV <sub>eff</sub> / 1 Min.
Clearance and creepage distances for control side - load side	≥ 5.5 mm
Overtoltage category	III
Pollution degree	2

Dimensions	PUSH IN connection	Screw connection
Clamping range (nominal / min. / max.)	mm <sup>2</sup> 1.5 / 0.14 / 2.5	1.5 / 0.14 / 2.5
Depth x width x height	mm 87.8 / 6.4 / 89.4	87.8 / 6.4 / 89.6
<b>Note</b>	Accessories and dimensional drawings: refer to the TERMSERIES Accessories page. Further approvals and technical data can be found at <a href="http://eshop.weidmueller.com">eshop.weidmueller.com</a>	

**Ordering data**

Control side		24 V DC
Rated control voltage		24 V DC ±20 %
Nominal control current		11.5 mA DC (±10 %)
Power rating		280 mW
max. switching frequency (DC control voltage)		300 Hz
max. switching frequency (AC control voltage)		
Status indicator		Green LED
Protective circuit		Free-wheeling diode, Reverse polarity protection

Ordering data		
PUSH IN connection	Type	TOP 24VDC ACT
	Order No.	<b>2618750000</b>
Screw connection	Type	TOS 24VDC ACT
	Order No.	<b>1391680000</b>
<b>Note</b>		

**DRL power relay**

**1 CO contact, AC/DC coil**

- High wear resistance in case of AC loads
- High dielectric strength: 2,000 V



**Circuit diagram**  
View on pins from below

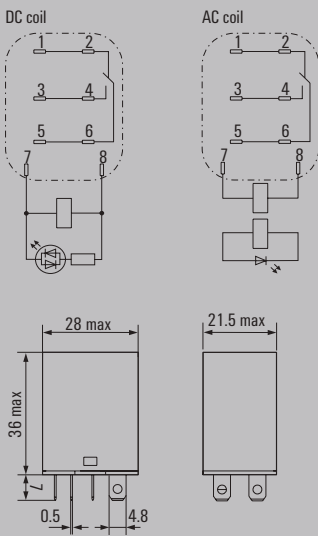

**Technical data**

Load side	
Rated switching voltage / Continuous current	250 V AC / 16 A
Max. switching voltage, AC	250 V
Inrush current	80 A / 50 ms
Min. switching power	10 mA @ 12 V
Contact type	1 CO contact (AgSnO)
Mechanical service life	10 x 10 <sup>6</sup> switching cycles
Max. switching frequency at rated load	0.1 Hz
General data	
Ambient temperature (operational)	-25 °C...55 °C
Storage temperature	-25 °C...55 °C
Humidity	35 % to 85 % relative humidity level
Approvals	cURus
Insulation coordinates	
Rated voltage	250 V
Impulse withstand voltage	5 kV (1.2/50 µs)
Dielectric strength for control side - load side	2.5 kV <sub>eff</sub> / 1 min
Dielectric strength of neighbouring contacts	2 kV <sub>eff</sub> / 1 min
Dielectric strength to mounting rail	
Clearance and creepage distances for control side - load side	≥ 4 mm
Overvoltage category	III
Pollution degree	3

Dimensions	Flat blade connections (4.8 mm x 0.5 mm)
Depth x width x height	mm 36 / 21.5 / 28

**Note** Further technical data can be found at [eshop.weidmueller.com](http://eshop.weidmueller.com)

**Applications**

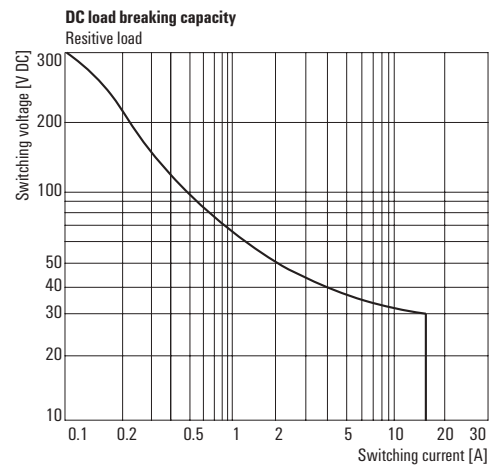
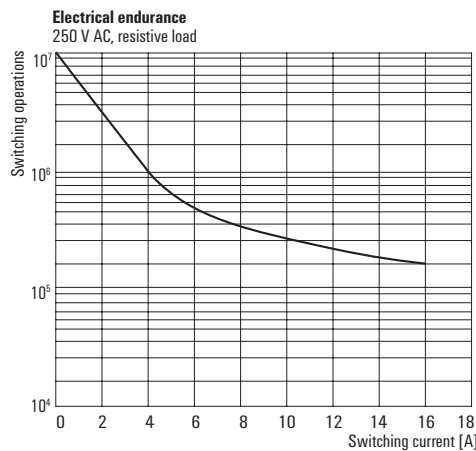
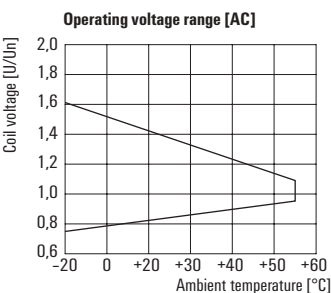
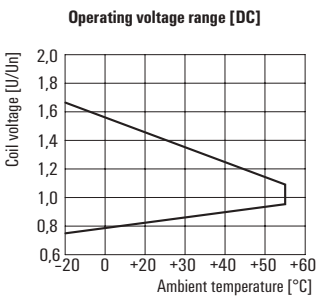

**DRL power relay**  
**1 CO contact, AC/DC coil**

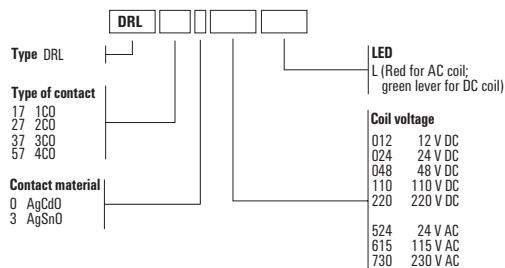

**Ordering data**

	12 V DC	24 V DC	48 V DC	110 V DC	220 V DC
<b>Control side</b>					
Rated control voltage	12 V DC	24 V DC	48 V DC	110 V DC	220 V DC
Rated current AC / DC	/ 75 mA	/ 36.9 mA	/ 18.5 mA	/ 10 mA	/ 5.2 mA
Power rating	0.9 W	0.9 W	0.9 W	0.9 W	0.9 W
Status indicator	Green LED	Green LED	Green LED	Green LED	Green LED

Ordering data						
1 CO contact	Type	DRL173012L	DRL173024L	DRL173048L	DRL173110L	DRL173220L
	Order No.	<b>2765100000</b>	<b>2765110000</b>	<b>2765120000</b>	<b>2765130000</b>	<b>2765140000</b>
	Type					
	Order No.					
<b>Note</b>						

**Ordering data**

	24 V AC	115 V AC	230 V AC
<b>Control side</b>			
Rated control voltage	24 V AC	115 V AC	230 V AC
Rated current AC / DC	54 mA /	12,9 mA /	6.8 mA /
Power rating	1.2 VA	1.2 VA	1.2 VA
Status indicator	red LED	red LED	red LED

Ordering data				
1 CO contact	Type	DRL173524L	DRL173615L	DRL173730L
	Order No.	<b>2765370000</b>	<b>2765380000</b>	<b>2765390000</b>
	Type			
	Order No.			
<b>Note</b>				

**DRL power relay**

**2 CO contact, AC/DC coil**

- High wear resistance in case of AC loads
- High dielectric strength: 2,000 V



**Circuit diagram**  
View on pins from below

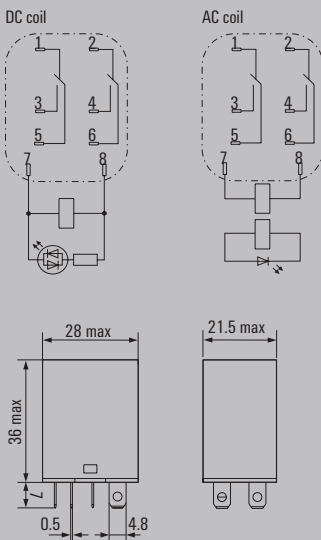

**Technical data**

Load side	
Rated switching voltage / Continuous current	250 V AC / 10 A
Max. switching voltage, AC	250 V
Inrush current	50 A / 50 ms
Min. switching power	10 mA @ 12 V
Contact type	2 CO contact (AgSnO)
Mechanical service life	10 x 10 <sup>6</sup> switching cycles
Max. switching frequency at rated load	0.1 Hz
General data	
Ambient temperature (operational)	-25 °C...55 °C
Storage temperature	-25 °C...55 °C
Humidity	35 % to 85 % relative humidity level
Approvals	cURus
Insulation coordinates	
Rated voltage	250 V
Impulse withstand voltage	5 kV (1.2/50 µs)
Dielectric strength for control side - load side	2.5 kV <sub>eff</sub> / 1 min
Dielectric strength of neighbouring contacts	1.2 kV <sub>eff</sub> / 1 min.
Dielectric strength to mounting rail	
Clearance and creepage distances for control side - load side	≥ 4 mm
Overvoltage category	III
Pollution degree	3

Dimensions	Flat blade connections (4.8 mm x 0.5 mm)
Depth x width x height	mm 36 / 21.5 / 28

**Note** Further technical data can be found at [eshop.weidmueller.com](http://eshop.weidmueller.com)

**Applications**

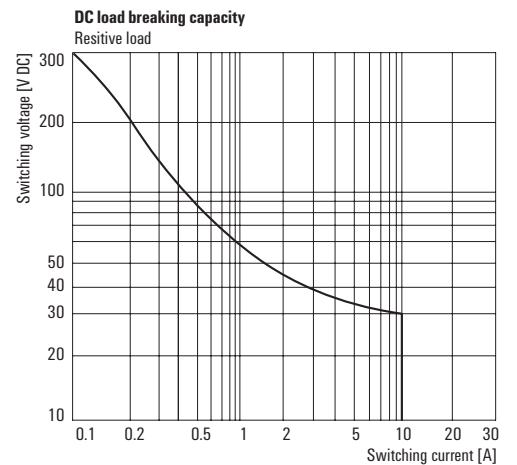
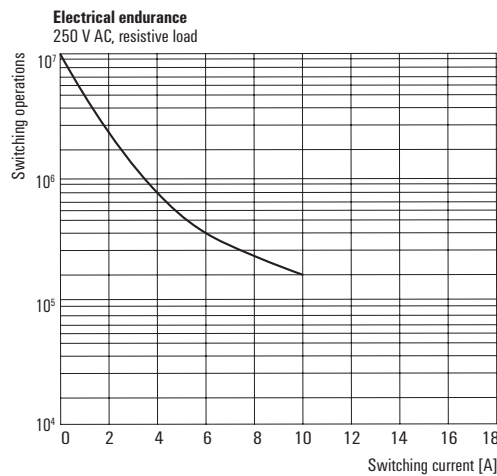
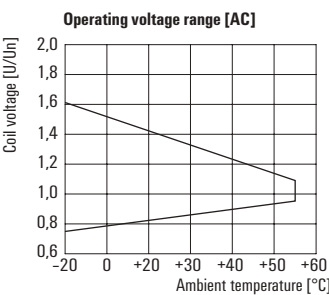
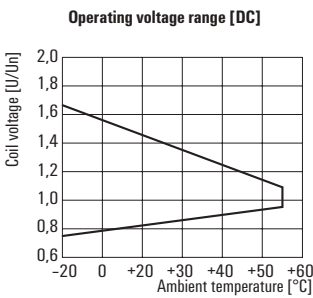

**DRL power relay**  
**2 CO contact, AC/DC coil**

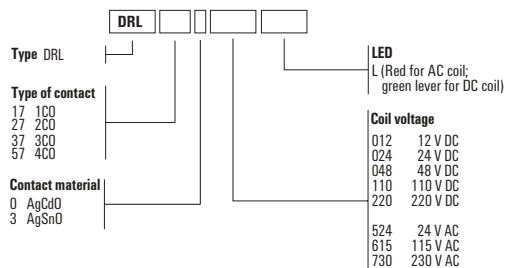

**Ordering data**

	12 V DC	24 V DC	48 V DC	110 V DC	220 V DC
<b>Control side</b>					
Rated control voltage	12 V DC	24 V DC	48 V DC	110 V DC	220 V DC
Rated current AC / DC	/ 75 mA	/ 36.9 mA	/ 18.5 mA	/ 10 mA	/ 5.2 mA
Power rating	0.9 W	0.9 W	0.9 W	0.9 W	0.9 W
Status indicator	Green LED	Green LED	Green LED	Green LED	Green LED

Ordering data						
2 CO contacts	Type	DRL273012L	DRL273024L	DRL273048L	DRL273110L	DRL273220L
	Order No.	<b>2765150000</b>	<b>2765160000</b>	<b>2765170000</b>	<b>2765180000</b>	<b>2765190000</b>
	Type					
	Order No.					
<b>Note</b>						

**Ordering data**

	24 V AC	115 V AC	230 V AC
<b>Control side</b>			
Rated control voltage	24 V AC	115 V AC	230 V AC
Rated current AC / DC	54 mA /	12,9 mA /	6.8 mA /
Power rating	1.2 VA	1.2 VA	1.2 VA
Status indicator	red LED	red LED	red LED

Ordering data				
2 CO contacts	Type	DRL273524L	DRL273615L	DRL273730L
	Order No.	<b>2765400000</b>	<b>2765410000</b>	<b>2765420000</b>
	Type			
	Order No.			
<b>Note</b>				

**DRL power relay**

**3 CO contact, AC/DC coil**

- High wear resistance in case of AC loads
- High dielectric strength: 2,000 V



**Circuit diagram**  
View on pins from below

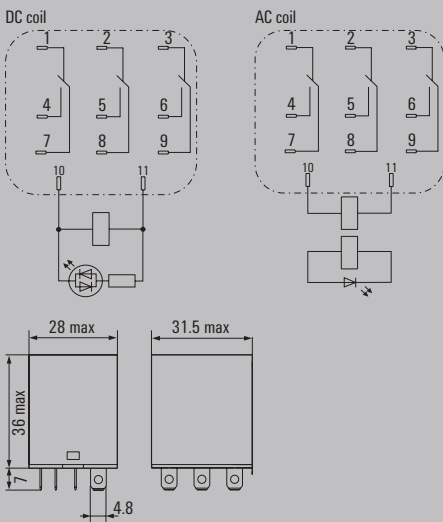

**Technical data**

Load side	
Rated switching voltage / Continuous current	250 V AC / 10 A
Max. switching voltage, AC	250 V
Inrush current	50 A / 50 ms
Min. switching power	10 mA @ 12 V
Contact type	3 CO contact (AgSnO)
Mechanical service life	10 x 10 <sup>6</sup> switching cycles
Max. switching frequency at rated load	0.1 Hz
General data	
Ambient temperature (operational)	-25 °C...55 °C
Storage temperature	-25 °C...55 °C
Humidity	35 % to 85 % relative humidity level
Approvals	cURus
Insulation coordinates	
Rated voltage	250 V
Impulse withstand voltage	5 kV (1.2/50 µs)
Dielectric strength for control side - load side	2.5 kV <sub>eff</sub> / 1 min
Dielectric strength of neighbouring contacts	2 kV <sub>eff</sub> / 1 min
Dielectric strength to mounting rail	
Clearance and creepage distances for control side - load side	≥ 4 mm
Overvoltage category	III
Pollution degree	3

Dimensions	Flat blade connections (4.8 mm x 0.5 mm)
Depth x width x height	mm 36 / 31.5 / 28

**Note** Further technical data can be found at [eshop.weidmueller.com](http://eshop.weidmueller.com)

**Applications**

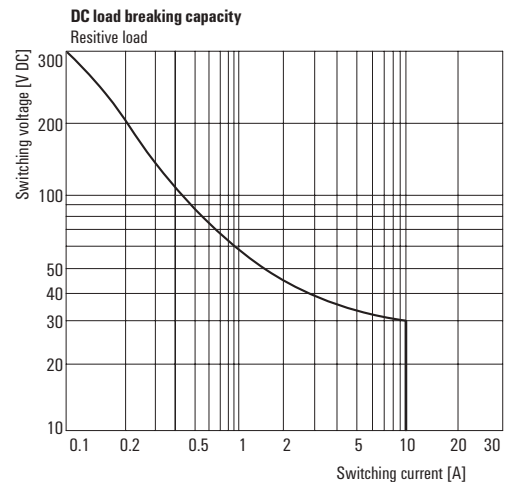
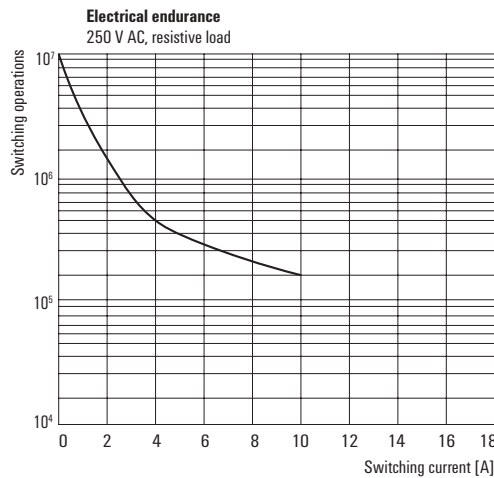
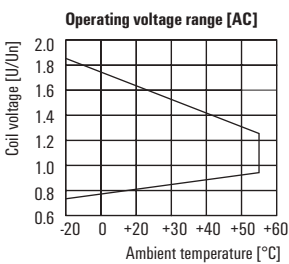
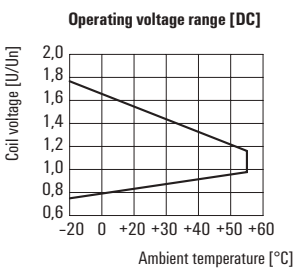

**DRL power relay**  
**3 CO contact, AC/DC coil**

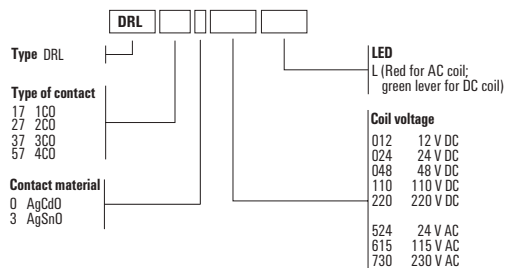

**Ordering data**

	12 V DC	24 V DC	48 V DC	110 V DC	220 V DC
<b>Control side</b>					
Rated control voltage	12 V DC	24 V DC	48 V DC	110 V DC	220 V DC
Rated current AC / DC	/ 120 mA	/ 60 mA	/ 30 mA	/ 13.1 mA	/ 6.7 mA
Power rating	1.4 W	1.4 W	1.4 W	1.4 W	1.4 W
Status indicator	Green LED	Green LED	Green LED	Green LED	Green LED

Ordering data						
3 CO contacts	Type	DRL373012L	DRL373024L	DRL373048L	DRL373110L	DRL373220L
	Order No.	<b>2765210000</b>	<b>2765220000</b>	<b>2765230000</b>	<b>2765240000</b>	<b>2765250000</b>
	Type					
	Order No.					
<b>Note</b>						

**Ordering data**

	24 V AC	115 V AC	230 V AC
<b>Control side</b>			
Rated control voltage	24 V AC	115 V AC	230 V AC
Rated current AC / DC	80 mA /	16 mA /	10 mA /
Power rating	2 VA	2 VA	2 VA
Status indicator	red LED	red LED	red LED

Ordering data				
3 CO contacts	Type	DRL373524L	DRL373615L	DRL373730L
	Order No.	<b>2765430000</b>	<b>2765440000</b>	<b>2765450000</b>
	Type			
	Order No.			
<b>Note</b>				

**DRL power relay**

**4 CO contact, AC/DC coil**

- High wear resistance in case of AC loads
- High dielectric strength: 2,000 V



**Circuit diagram**  
View on pins from below

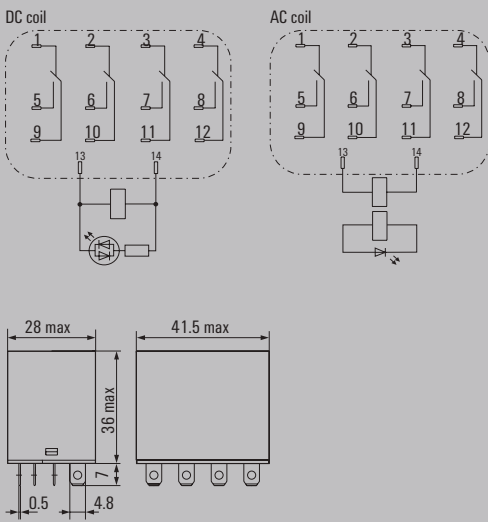

**Technical data**

Load side	
Rated switching voltage / Continuous current	250 V AC / 10 A
Max. switching voltage, AC	250 V
Inrush current	50 A / 50 ms
Min. switching power	10 mA @ 12 V
Contact type	4 CO contact (AgSnO)
Mechanical service life	10 x 10 <sup>6</sup> switching cycles
Max. switching frequency at rated load	0.1 Hz
General data	
Ambient temperature (operational)	-25 °C...55 °C
Storage temperature	-25 °C...55 °C
Humidity	35 % to 85 % relative humidity level
Approvals	cURus
Insulation coordinates	
Rated voltage	250 V
Impulse withstand voltage	5 kV (1.2/50 µs)
Dielectric strength for control side - load side	2.5 kV <sub>eff</sub> / 1 min
Dielectric strength of neighbouring contacts	2 kV <sub>eff</sub> / 1 min
Dielectric strength to mounting rail	
Clearance and creepage distances for control side - load side	≥ 4 mm
Overvoltage category	III
Pollution degree	3

Dimensions	Flat blade connections (4.8 mm x 0.5 mm)
Depth x width x height	mm 36 / 41.5 / 28

**Note** Further technical data can be found at [eshop.weidmueller.com](http://eshop.weidmueller.com)

**Applications**

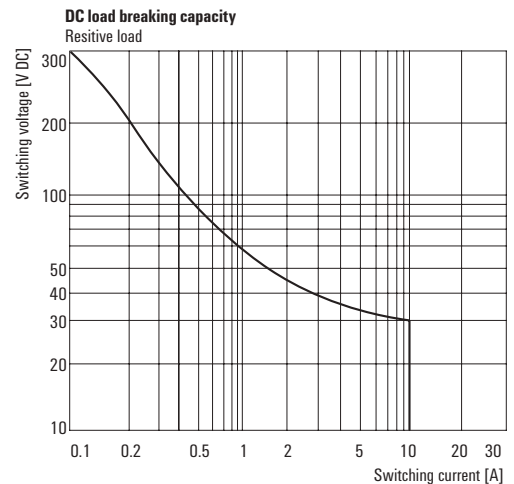
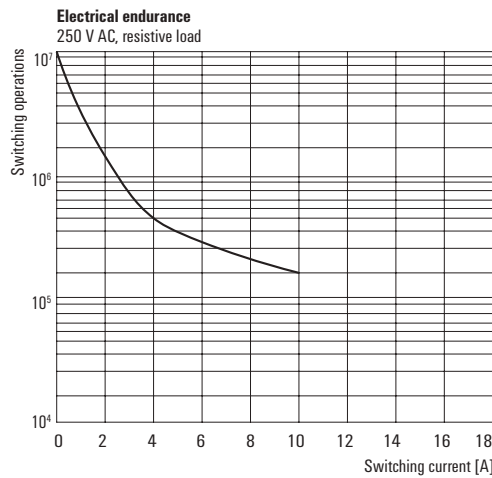
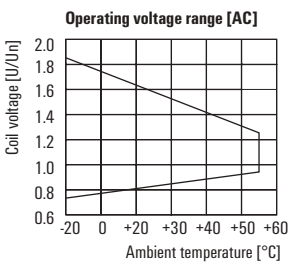
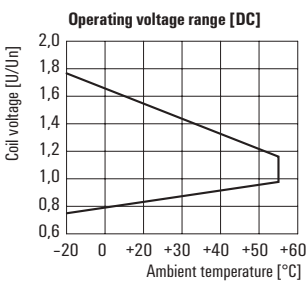

**DRL power relay**  
**4 CO contact, AC/DC coil**

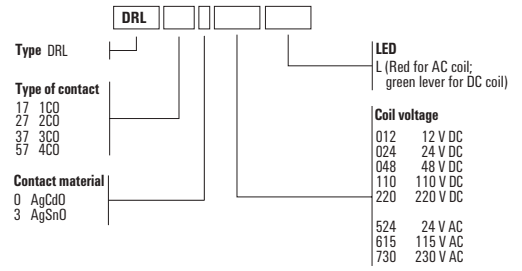

**Ordering data**

	12 V DC	24 V DC	48 V DC	110 V DC	220 V DC
<b>Control side</b>					
Rated control voltage	12 V DC	24 V DC	48 V DC	110 V DC	220 V DC
Rated current AC / DC	/ 125 mA	/ 66.7 mA	/ 31.2 mA	/ 16.2 mA	/ 7.6 mA
Power rating	1.5 W	1.5 W	1.5 W	1.5 W	1.5 W
Status indicator	Green LED	Green LED	Green LED	Green LED	Green LED

Ordering data						
4 CO contacts	Type	DRL573012L	DRL573024L	DRL573048L	DRL573110L	DRL573220L
	Order No.	<b>2765260000</b>	<b>2765270000</b>	<b>2765280000</b>	<b>2765290000</b>	<b>2765300000</b>
	Type					
	Order No.					
<b>Note</b>						

**Ordering data**

	24 V AC	115 V AC	230 V AC
<b>Control side</b>			
Rated control voltage	24 V AC	115 V AC	230 V AC
Rated current AC / DC	/ 93.5 mA	/ 25.5 mA	/ 13.1 mA
Power rating	2.5 VA	2.5 VA	2.5 VA
Status indicator	red LED	red LED	red LED

Ordering data				
4 CO contacts	Type	DRL573524L	DRL573615L	DRL573730L
	Order No.	<b>2765460000</b>	<b>2765470000</b>	<b>2765480000</b>
	Type			
	Order No.			
<b>Note</b>				

Accessories for DRL relays

Socket module with leaf spring connection, 2 CO contacts

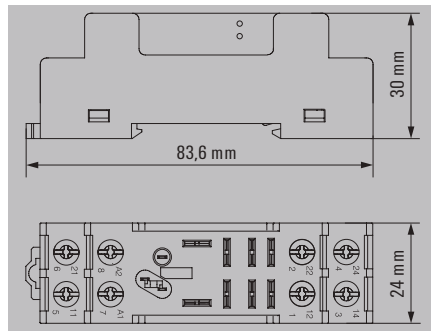

Socket module with leaf spring connection, 3 CO contacts

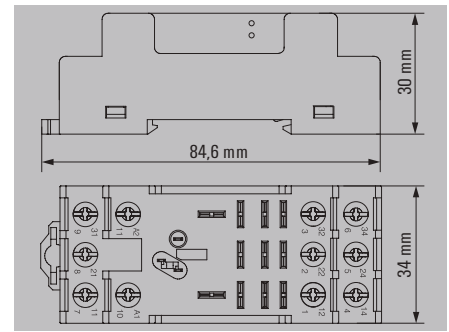

Technical data

Load side	
Rated switching voltage	250 V AC
Max. switching voltage, AC	250 V
Continuous current	10 A
General data	
Ambient temperature (operational)	-40 °C...65 °C
Storage temperature	-40 °C...85 °C
Approvals	CE; cURus; UKCA
Insulation coordinates	
Protection degree	IP10
Clearance and creepage distances for control side - load side	≥ 6 mm
Dielectric strength for control side - load side	2 kV <sub>eff</sub> / 1 min
Dielectric strength of neighbouring contacts	2 kV <sub>eff</sub> / 1 min
Impulse withstand voltage	4 kV (1.2/50 µs)
Connection data	
Clamping range (nominal / min. / max.)	/ 0.5 / 2.5 mm <sup>2</sup>
Tightening torque	0.8...1 Nm
Stripping length, rated connection	8 mm
Note	

Rated switching voltage	250 V AC
Max. switching voltage, AC	250 V
Continuous current	10 A
Ambient temperature (operational)	-40 °C...65 °C
Storage temperature	-40 °C...85 °C
Approvals	CE; cURus; UKCA
Protection degree	IP10
Clearance and creepage distances for control side - load side	≥ 6 mm
Dielectric strength for control side - load side	2 kV <sub>eff</sub> / 1 min
Dielectric strength of neighbouring contacts	2 kV <sub>eff</sub> / 1 min
Impulse withstand voltage	4 kV (1.2/50 µs)
Clamping range (nominal / min. / max.)	/ 0.5 / 2.5 mm <sup>2</sup>
Tightening torque	0.8...1 Nm
Stripping length, rated connection	8 mm

Rated switching voltage	250 V AC
Max. switching voltage, AC	250 V
Continuous current	10 A
Ambient temperature (operational)	-40 °C...65 °C
Storage temperature	-40 °C...85 °C
Approvals	CE; cURus; UKCA
Protection degree	IP10
Clearance and creepage distances for control side - load side	≥ 6 mm
Dielectric strength for control side - load side	2 kV <sub>eff</sub> / 1 min
Dielectric strength of neighbouring contacts	2 kV <sub>eff</sub> / 1 min
Impulse withstand voltage	4 kV (1.2/50 µs)
Clamping range (nominal / min. / max.)	/ 0.5 / 2.5 mm <sup>2</sup>
Tightening torque	0.8...1 Nm
Stripping length, rated connection	8 mm

Ordering data

Base, rail-mountable	
Note	

Type	Qty.	Order No.
SLD F 2CO	10	7760056225

Type	Qty.	Order No.
SLD F 3CO	10	7760056226

Accessories

Retaining clip	
Metal retaining clip	
LED module / protection modules	
LED 110 - 230 V UC green	
LED 24 - 60 V UC green	
LED 6 - 24 V UC green	
LED 110 - 230 V DC green and free-wheeling diode	
LED 24 - 60 V DC green and free-wheeling diode	
LED 6 - 24 V DC green and free-wheeling diode	
Free-wheeling diode 6 - 230 V DC	
RC element 110 - 230 V AC; 4.7 kΩ / 10 nF	
RC element 110 - 230 V AC; 100 Ω / 220 nF and LED green	
RC element 6 - 230 V AC	
Screwdriver	
Screwdriver, insulated PH2 SlimLine	
Screwdriver, insulated PH2	
Screwdriver PH2	

Type	Qty.	Order No.
DRM/DRL CLIP M	10	7760056108
RIM 3 110/230VUC	10	7940018455
RIM 3 24/60VUC	10	7760056018
RIM 3 6/24VUC	10	7940018457
RIM 2 110/230VDC	10	7760056017
RIM 2 24/60VDC	10	7760056016
RIM 2 6/24VDC	10	7760056015
RIM 1 6/230VDC	10	7760056169
RIM 3 110/230VAC	10	7760056014
RIM 3 110/230VAC LED	10	7760056045
SDIK SLIM PH2 X 100	1	2749660000
SDIK PH2 X 100	1	2749900000
SDK PH2 X 100	1	2749420000

Type	Qty.	Order No.
SLD CLIP 3CO M	10	7760056234
RIM 3 110/230VUC	10	7940018455
RIM 3 24/60VUC	10	7760056018
RIM 3 6/24VUC	10	7940018457
RIM 2 110/230VDC	10	7760056017
RIM 2 24/60VDC	10	7760056016
RIM 2 6/24VDC	10	7760056015
RIM 1 6/230VDC	10	7760056169
RIM 3 110/230VAC	10	7760056014
RIM 3 110/230VAC LED	10	7760056045
SDIK SLIM PH2 X 100	1	2749660000
SDIK PH2 X 100	1	2749900000
SDK PH2 X 100	1	2749420000

Note

Further accessories can be found on the article at [eshop.weidmueller.com](https://eshop.weidmueller.com)

Further accessories can be found on the article at [eshop.weidmueller.com](https://eshop.weidmueller.com)

**Socket module with leaf spring connection, 4 CO contacts**

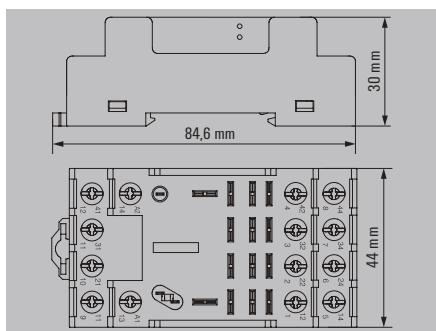

250 V AC
250 V
10 A
-40 °C...65 °C
-40 °C...85 °C
CE; cURus; UKCA
IP10
≥ 6 mm
2 kV <sub>eff</sub> / 1 min
2 kV <sub>eff</sub> / 1 min
4 kV (1.2/50 µs)
/ 0.5 / 2.5 mm <sup>2</sup>
0.8...1 Nm
8 mm

Type	Qty.	Order No.
SLD F 4CO	10	7760056227

Type	Qty.	Order No.
SLD CLIP 4CO M	10	7760056235
RIM 5 6/230VDC	10	1174650000
RIM 5 6/230VAC	10	1174670000
SDIK SLIM PH2 X 100	1	2749660000
SDIK PH2 X 100	1	2749900000
SDK PH2 X 100	1	2749420000

Further accessories can be found on the article at [eshop.weidmueller.com](http://eshop.weidmueller.com)

Application range

C

**DRW power relay**

**2 CO contact, AC/DC coil**

**3 CO contact, AC/DC coil**

- Suitable for switching high load voltages
- With LED and test button



**Circuit diagram**

View on pins from below

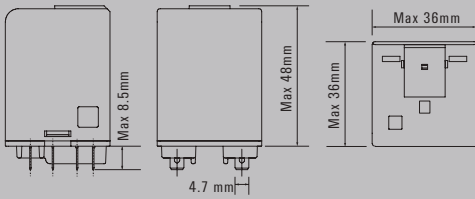
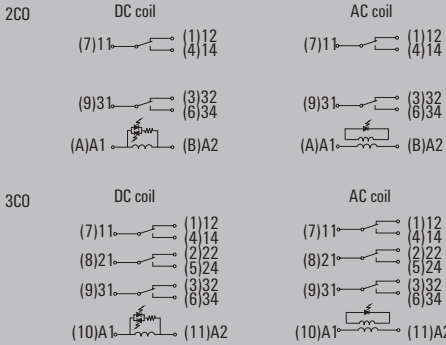

**Technical data**

Load side	
Rated switching voltage / Continuous current	400 VAC / 16 A
Max. switching voltage, AC	400 V
Inrush current	80 A / 50 ms
Min. switching power	100 mA @ 12 V
Contact type	2 CO contact (AgSnO)
Mechanical service life	20 x 10 <sup>6</sup> switching cycles
Max. switching frequency at rated load	0.1 Hz
General data	
Ambient temperature (operational)	-40 °C...60 °C
Storage temperature	-40 °C...60 °C
Humidity	5...85 % rel. humidity, no condensation
Approvals	cURus
Insulation coordinates	
Rated voltage	400 V
Impulse withstand voltage	
Dielectric strength for control side - load side	4 kV <sub>eff</sub> / 1 Min.
Dielectric strength of neighbouring contacts	4 kV <sub>eff</sub> / 1 Min.
Dielectric strength to mounting rail	
Clearance and creepage distances for control side - load side	≥ 6,3 mm
Overvoltage category	III
Pollution degree	3

Dimensions	Flat blade connections (4.8 mm x 0.5 mm)
Depth x width x height	mm 48 / 36 / 36

**Note** Further technical data can be found at [eshop.weidmueller.com](http://eshop.weidmueller.com)

**Applications**

**Operating voltage range [DC]**

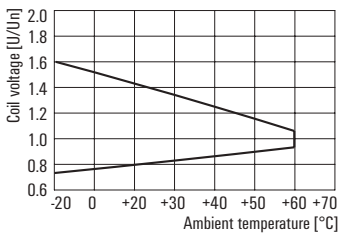

**Operating voltage range [AC]**

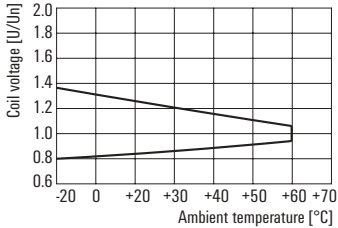

**Electrical endurance**

250 V AC, resistive load

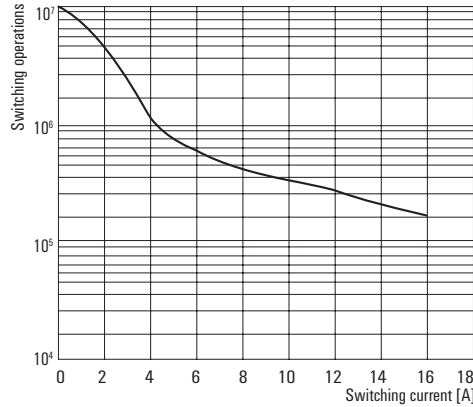

**DC load breaking capacity**

Resistive load

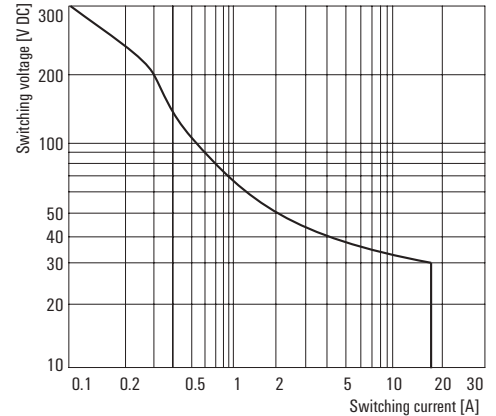

**DRW power relay**  
**2 CO contact, AC/DC coil**  
**3 CO contact, AC/DC coil**

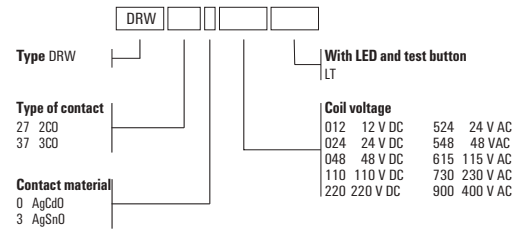

**Ordering data**

	12 V DC	24 V DC	48 V DC	110 V DC	220 V DC
<b>Control side</b>					
Rated control voltage	12 V DC	24 V DC	48 V DC	110 V DC	220 V DC
Rated current AC / DC	/ 120 mA	/ 60 mA	/ 30 mA	/ 13 mA	/ 6.7 mA
Power rating	1.7 W	1.7 W	1.7 W	1.7 W	1.7 W
Status indicator	Green LED	Green LED	Green LED	Green LED	Green LED

Ordering data						
2 CO contacts	Type	DRW273012LT	DRW273024LT	DRW273048LT	DRW273110LT	DRW273220LT
	Order No.	<b>2765590000</b>	<b>2765600000</b>	<b>2765610000</b>	<b>2765620000</b>	<b>2765630000</b>
3 CO contacts	Type	DRW373012LT	DRW373024LT	DRW373048LT	DRW373110LT	DRW373220LT
	Order No.	<b>2765640000</b>	<b>2765650000</b>	<b>2765660000</b>	<b>2765670000</b>	<b>2765680000</b>

Note					

**Ordering data**

	24 V AC	48 V AC	115 V AC	230 V AC	400 V AC
<b>Control side</b>					
Rated control voltage	24 V AC	48 V AC	115 V AC	230 V AC	400 V AC
Rated current AC / DC	101.7 mA /	50.5 mA /	21 mA /	10,6 mA /	6.1 mA /
Power rating	2.5 VA	2.5 VA	2.5 VA	2.5 VA	2.5 VA
Status indicator	red LED	red LED	red LED	red LED	red LED

Ordering data						
2 CO contacts	Type	DRW273524LT	DRW273548LT	DRW273615LT	DRW273730LT	DRW273900LT
	Order No.	<b>2765490000</b>	<b>2765500000</b>	<b>2765510000</b>	<b>2765520000</b>	<b>2765530000</b>
3 CO contacts	Type	DRW373524LT	DRW373548LT	DRW373615LT	DRW373730LT	DRW373900LT
	Order No.	<b>2765540000</b>	<b>2765550000</b>	<b>2765560000</b>	<b>2765570000</b>	<b>2765580000</b>

Note					

**DRH DC relay**

- 1 NO contact AC/DC coil**
- 1 NC contact AC/DC coil**

- Suitable for switching high DC loads
- With blowout magnet
- With LED and test button
- For switching high DC loads up to 10 A at 220 V DC



**Circuit diagram**

View on pins from below

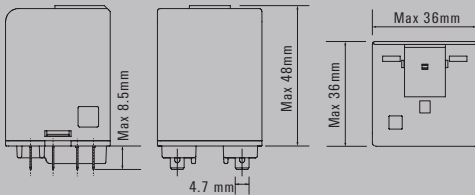
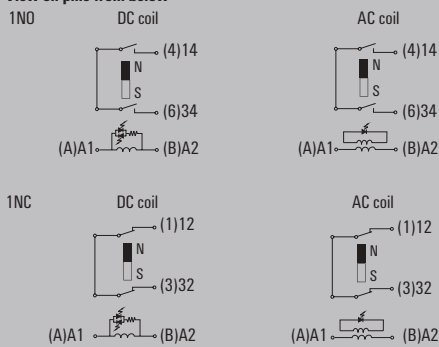

**Technical data**

Load side	
Rated switching voltage / Continuous current	500 V AC / 16 A
Max. switching voltage, AC	400 V
Inrush current	80 A / 50 ms
Min. switching power	100 mA @ 12 V
DC / AC Switching capacity (resistive), max.	2200 W @ 220 V / 8000 VA
Contact material	AgSnO
Mechanical service life	10 x 10 <sup>6</sup> switching cycles
Max. switching frequency at rated load	0.1 Hz
General data	
Ambient temperature (operational)	-40 °C...60 °C
Storage temperature	-40 °C...60 °C
Humidity	5...85 % rel. humidity, no condensation
Approvals	cURus
Insulation coordinates	
Rated voltage	500 V
Impulse withstand voltage	
Dielectric strength for control side - load side	4 kV <sub>eff</sub> / 1 min
Dielectric strength of neighbouring contacts	
Dielectric strength to mounting rail	
Clearance and creepage distances for control side - load side	≥ 8 mm
Overvoltage category	III
Pollution degree	3
Dimensions	
	<b>Flat blade connections (4.8 mm x 0.5 mm)</b>
Depth x width x height	mm 48 / 36 / 36
Note	
	Further technical data can be found at <a href="http://eshop.weidmueller.com">eshop.weidmueller.com</a>

**Applications**

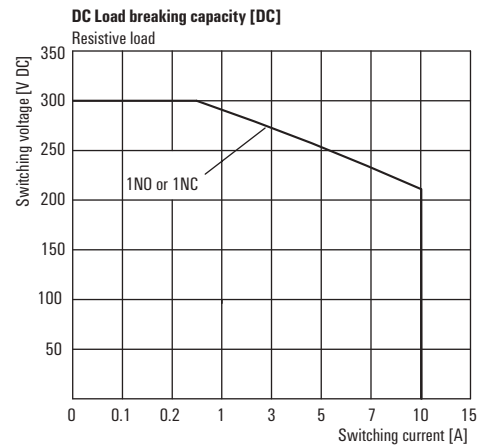
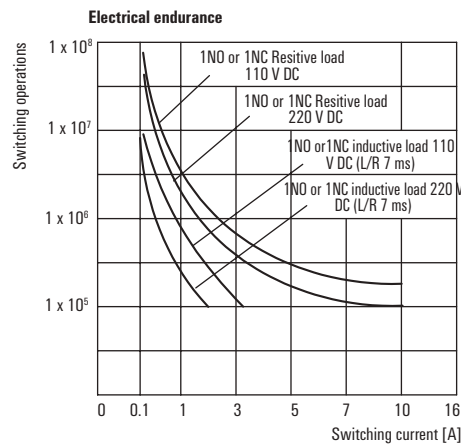
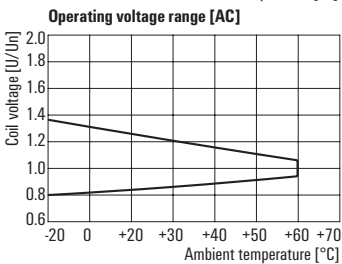
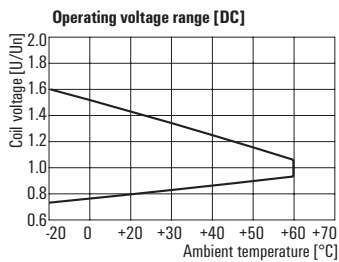

**DRH DC relay**  
**1 NO contact AC/DC coil**  
**1 NC contact AC/DC coil**

Type  
 DRH

Type of contact  
 173 1NO  
 174 1NC

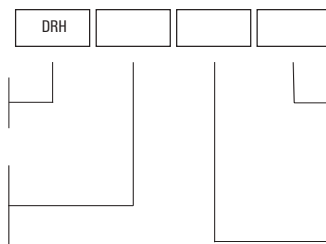

With LED and test lever  
 LT

Coil voltage			
012	12 V DC	524	24 V AC
024	24 V DC	548	48 V AC
048	48 V DC	615	115 V AC
110	110 V DC	730	230 V AC
220	220 V DC		

**Ordering data**

	12 V DC	24 V DC	48 V DC	110 V DC	220 V DC
<b>Control side</b>					
Rated control voltage	12 V DC	24 V DC	48 V DC	110 V DC	220 V DC
Rated current AC / DC	/ 120 mA	/ 60 mA	/ 30 mA	/ 13 mA	/ 6.7 mA
Power rating	1.5 W	1.5 W	1.5 W	1.5 W	1.5 W
Status indicator	Green LED	Green LED	Green LED	Green LED	red LED

Ordering data					
1 NO contact	Type	DRH173012LT	DRH173024LT	DRH173048LT	DRH173110LT
	Order No.	<b>1219840000</b>	<b>1219850000</b>	<b>1219860000</b>	<b>1219870000</b>
1 NC contact	Type	DRH174012LT	DRH174024LT	DRH174048LT	DRH174110LT
	Order No.	<b>1219940000</b>	<b>1219950000</b>	<b>1219960000</b>	<b>1219970000</b>
<b>Ordering data</b>					
<b>Test-button lock</b>	Type	TEST LEVER BLOCK DRH/DRW	TEST LEVER BLOCK DRH/DRW	TEST LEVER BLOCK DRH/DRW	TEST LEVER BLOCK DRH/DRW
	Order No.	<b>7760056249</b>	<b>7760056249</b>	<b>7760056249</b>	<b>7760056249</b>
<b>Note</b>					

**Ordering data**

	24 V AC	48 V AC	115 V AC	230 V AC
<b>Control side</b>				
Rated control voltage	24 V AC	48 V AC	115 V AC	230 V AC
Rated current AC / DC	101.7 mA /	50.5 mA /	21 mA /	10,6 mA /
Power rating	2.5 VA	2.5 VA	2.5 VA	2.5 VA
Status indicator	red LED	red LED	red LED	red LED

Ordering data					
1 NO contact	Type	DRH173524LT	DRH173548LT	DRH173615LT	DRH173730LT
	Order No.	<b>1219890000</b>	<b>1219910000</b>	<b>1219920000</b>	<b>1219930000</b>
1 NC contact	Type	DRH174524LT	DRH174548LT	DRH174615LT	DRH174730LT
	Order No.	<b>1219990000</b>	<b>1220010000</b>	<b>1220020000</b>	<b>1220030000</b>
<b>Ordering data</b>					
<b>Test-button lock</b>	Type	TEST LEVER BLOCK DRH/DRW	TEST LEVER BLOCK DRH/DRW	TEST LEVER BLOCK DRH/DRW	TEST LEVER BLOCK DRH/DRW
	Order No.	<b>7760056249</b>	<b>7760056249</b>	<b>7760056249</b>	<b>7760056249</b>
<b>Note</b>					

**DRH DC relay**

**1 NO contact / 1 NC contact AC/DC coil**

- Suitable for switching high DC loads
- With blowout magnet
- With LED and test button
- For switching high DC loads up to 3 A at 220 V DC



**Circuit diagram**  
View on pins from below

1NO/1NC

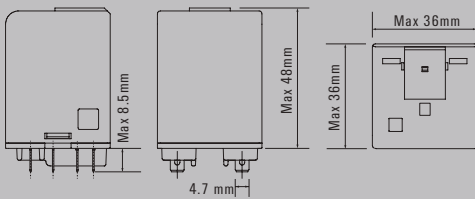
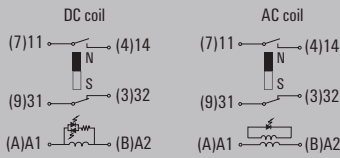

**Technical data**

Load side	
Rated switching voltage / Continuous current	250 V AC / 16 A
Max. switching voltage, AC	400 V
Inrush current	80 A / 50 ms
Min. switching power	100 mA @ 12 V
DC / AC Switching capacity (resistive), max.	660 W @ 220 V / 4000 VA
Contact material	AgSnO
Mechanical service life	10 x 10 <sup>6</sup> switching cycles
Max. switching frequency at rated load	0.1 Hz
General data	
Ambient temperature (operational)	-40 °C...60 °C
Storage temperature	-40 °C...60 °C
Humidity	5...85 % rel. humidity, no condensation
Approvals	cURus
Insulation coordinates	
Rated voltage	400 V
Impulse withstand voltage	
Dielectric strength for control side - load side	4 kV <sub>eff</sub> / 1 min
Dielectric strength of neighbouring contacts	4 kV <sub>eff</sub> / 1 min
Dielectric strength to mounting rail	
Clearance and creepage distances for control side - load side	≥ 6,3 mm
Overvoltage category	III
Pollution degree	3
Dimensions	
Flat blade connections (4.8 mm x 0.5 mm)	
Depth x width x height	mm 48 / 36 / 36
Note	
Further technical data can be found at <a href="http://eshop.weidmueller.com">eshop.weidmueller.com</a>	

**Applications**

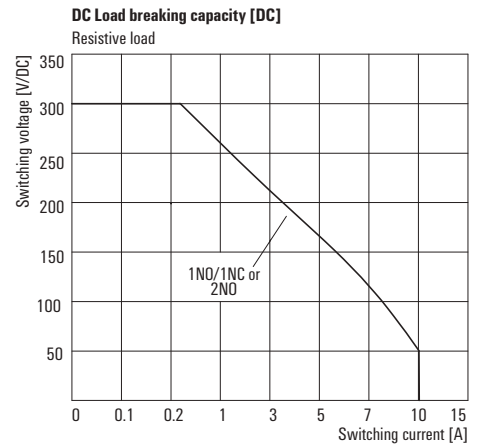
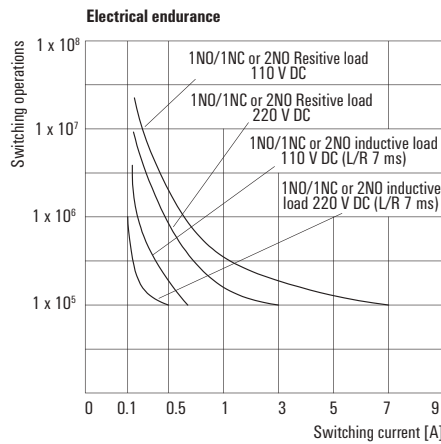
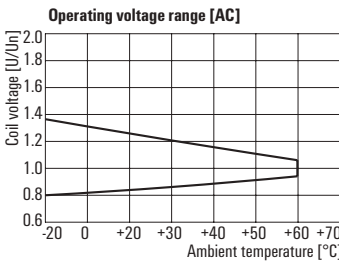
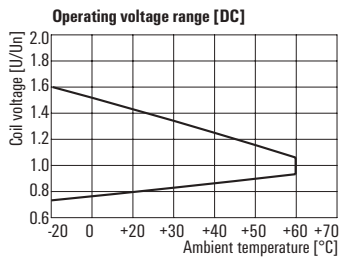

**DRH DC relay**

**1 NO contact / 1 NC contact AC/DC coil**

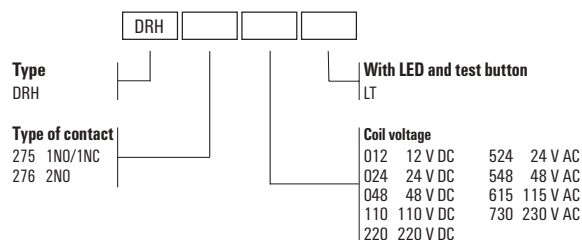

Ordering data	12 V DC	24 V DC	48 V DC	110 V DC	220 V DC
<b>Control side</b>					
Rated control voltage	12 V DC	24 V DC	48 V DC	110 V DC	220 V DC
Rated current AC / DC	/ 120 mA	/ 60 mA	/ 30 mA	/ 13 mA	/ 6.7 mA
Power rating	1.5 W	1.5 W	1.5 W	1.5 W	1.5 W
Status indicator	Green LED	Green LED	Green LED	Green LED	Green LED

<b>Ordering data</b>					
1 NO / 1 NC contact	Type DRH275012LT	Type DRH275024LT	Type DRH275048LT	Type DRH275110LT	Type DRH275220LT
Order No.	1220040000	1220050000	1220060000	1220070000	1220080000
Test-button lock	Type TEST LEVER BLOCK DRH/DRW	Type TEST LEVER BLOCK DRH/DRW	Type TEST LEVER BLOCK DRH/DRW	Type TEST LEVER BLOCK DRH/DRW	Type TEST LEVER BLOCK DRH/DRW
Order No.	7760056249	7760056249	7760056249	7760056249	7760056249
<b>Note</b>					

Ordering data	24 V AC	48 V AC	115 V AC	230 V AC
<b>Control side</b>				
Rated control voltage	24 V AC	48 V AC	115 V AC	230 V AC
Rated current AC / DC	101.7 mA /	50.5 mA /	21 mA /	10,6 mA /
Power rating	2.5 VA	2.5 VA	2.5 VA	2.5 VA
Status indicator	red LED	red LED	red LED	red LED

<b>Ordering data</b>				
1 NO / 1 NC contact	Type DRH275524LT	Type DRH275548LT	Type DRH275615LT	Type DRH275730LT
Order No.	1220090000	1220110000	1220120000	1220130000
Test-button lock	Type TEST LEVER BLOCK DRH/DRW	Type TEST LEVER BLOCK DRH/DRW	Type TEST LEVER BLOCK DRH/DRW	Type TEST LEVER BLOCK DRH/DRW
Order No.	7760056249	7760056249	7760056249	7760056249
<b>Note</b>				

**DRH DC relay**

**2 NO contact AC/DC coil**

- Suitable for switching high DC loads
- With blowout magnet
- With LED and test button
- For switching high DC loads up to 3 A at 220 V DC



**Circuit diagram**  
View on pins from below

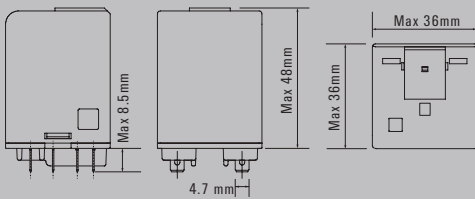
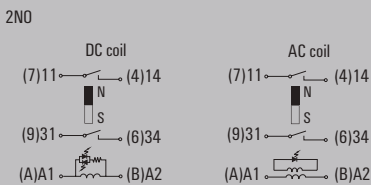

**Technical data**

Load side	
Rated switching voltage / Continuous current	250 V AC / 16 A
Max. switching voltage, AC	400 V
Inrush current	80 A / 50 ms
Min. switching power	100 mA @ 12 V
DC / AC Switching capacity (resistive), max.	660 W @ 220 V / 4000 VA
Contact material	AgSnO
Mechanical service life	10 x 10 <sup>6</sup> switching cycles
Max. switching frequency at rated load	0.1 Hz
General data	
Ambient temperature (operational)	-40 °C...60 °C
Storage temperature	-40 °C...60 °C
Humidity	5...85 % rel. humidity, no condensation
Approvals	cURus
Insulation coordinates	
Rated voltage	400 V
Impulse withstand voltage	
Dielectric strength for control side - load side	4 kV <sub>eff</sub> / 1 min
Dielectric strength of neighbouring contacts	4 kV <sub>eff</sub> / 1 min
Dielectric strength to mounting rail	
Clearance and creepage distances for control side - load side	≥ 6,3 mm
Overvoltage category	III
Pollution degree	3
Dimensions	
Flat blade connections (4.8 mm x 0.5 mm)	
Depth x width x height	mm 48 / 36 / 36
Note	
Further technical data can be found at <a href="http://eshop.weidmueller.com">eshop.weidmueller.com</a>	

**Applications**

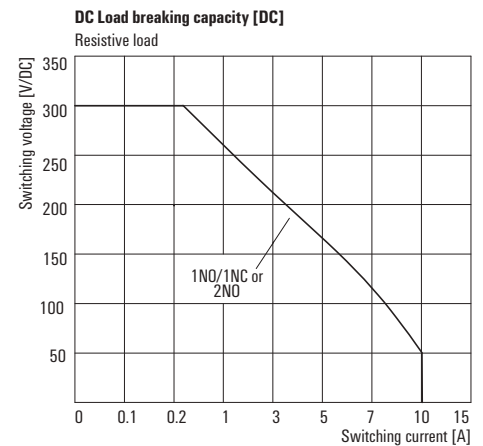
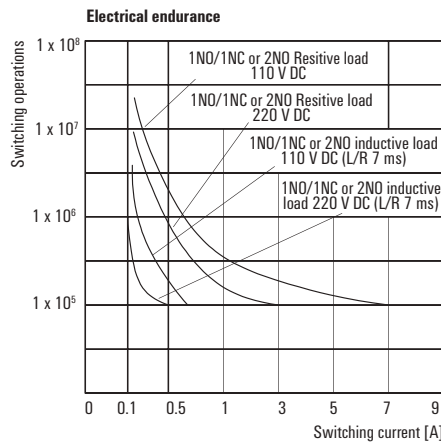
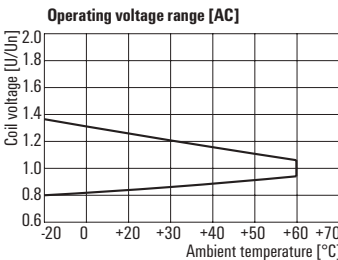
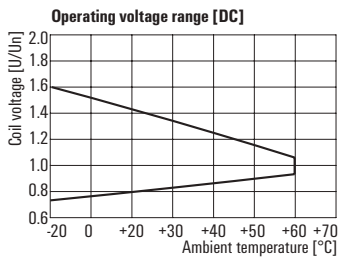

**DRH DC relay**  
**2 NO contact AC/DC coil**

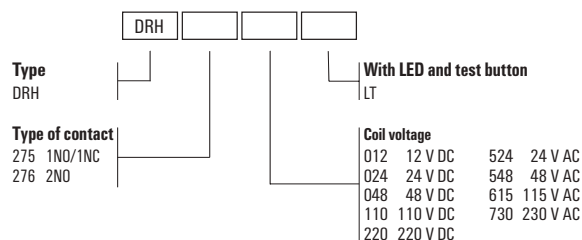

Ordering data	12 V DC	24 V DC	48 V DC	110 V DC	220 V DC
<b>Control side</b>					
Rated control voltage	12 V DC	24 V DC	48 V DC	110 V DC	220 V DC
Rated current AC / DC	/ 120 mA	/ 60 mA	/ 30 mA	/ 13 mA	/ 6.7 mA
Power rating	1.5 W	1.5 W	1.5 W	1.5 W	1.5 W
Status indicator	Green LED	Green LED	Green LED	Green LED	Green LED

<b>Ordering data</b>					
2 NO contacts	Type DRH276012LT Order No. <b>1220140000</b>	Type DRH276024LT Order No. <b>1220150000</b>	Type DRH276048LT Order No. <b>1220170000</b>	Type DRH276110LT Order No. <b>1220180000</b>	Type DRH276220LT Order No. <b>1220190000</b>
<b>Ordering data</b>					
Test-button lock	Type TEST LEVER BLOCK DRH/DRW Order No. <b>7760056249</b>	Type TEST LEVER BLOCK DRH/DRW Order No. <b>7760056249</b>	Type TEST LEVER BLOCK DRH/DRW Order No. <b>7760056249</b>	Type TEST LEVER BLOCK DRH/DRW Order No. <b>7760056249</b>	Type TEST LEVER BLOCK DRH/DRW Order No. <b>7760056249</b>
<b>Note</b>					

Ordering data	24 V AC	48 V AC	115 V AC	230 V AC
<b>Control side</b>				
Rated control voltage	24 V AC	48 V AC	115 V AC	230 V AC
Rated current AC / DC	101.7 mA /	50.5 mA /	21 mA /	10,6 mA /
Power rating	2.5 VA	2.5 VA	2.5 VA	2.5 VA
Status indicator	red LED	red LED	red LED	red LED

<b>Ordering data</b>				
2 NO contacts	Type DRH276524LT Order No. <b>1220200000</b>	Type DRH276548LT Order No. <b>1220210000</b>	Type DRH276615LT Order No. <b>1220220000</b>	Type DRH276730LT Order No. <b>1220230000</b>
<b>Ordering data</b>				
Test-button lock	Type TEST LEVER BLOCK DRH/DRW Order No. <b>7760056249</b>	Type TEST LEVER BLOCK DRH/DRW Order No. <b>7760056249</b>	Type TEST LEVER BLOCK DRH/DRW Order No. <b>7760056249</b>	Type TEST LEVER BLOCK DRH/DRW Order No. <b>7760056249</b>
<b>Note</b>				

Accessories for DRH and DRW relays

Socket module with leaf spring connection, 3 CO contacts

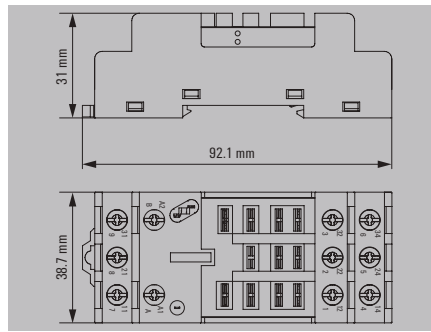

Technical data

<b>Load side</b>	
Rated switching voltage	250 V AC
Max. switching voltage, AC	250 V
Continuous current	16 A
<b>General data</b>	
Ambient temperature (operational)	-40 °C...60 °C
Storage temperature	-40 °C...60 °C
Approvals	CE, cURus, UKCA
<b>Insulation coordinates</b>	
Protection degree	IP10
Clearance and creepage distances for control side - load side	
Dielectric strength for control side - load side	4 kV <sub>eff</sub> / 1 min
Dielectric strength of neighbouring contacts	4 kV <sub>eff</sub> / 1 min
Impulse withstand voltage	7.3 kV (1.2/50 µs)
<b>Connection data</b>	
Clamping range (nominal / min. / max.)	/ 0.5 / 4 mm <sup>2</sup>
Tightening torque	0.5...1.2 Nm
Stripping length, rated connection	8 mm
<b>Note</b>	

Ordering data

	Base, rail-mountable		
<b>Note</b>			
<b>Type</b>	<b>Qty.</b>	<b>Order No.</b>	
SPW ECO 3CO	10	1220250000	

Accessories

<b>LED module / protection modules</b>			
	RC element 6 - 230 V AC		
	Free-wheeling diode 6 - 230 V DC		
<b>Retaining clip</b>			
	Metal retaining clip		
<b>Screwdriver</b>			
	Screwdriver, insulated PH2 SlimLine		
	Screwdriver, insulated PH2		
	Screwdriver PH2		
<b>Type</b>	<b>Qty.</b>	<b>Order No.</b>	
RIM 5 6/230VAC	10	1174670000	
RIM 5 6/230VDC	10	1174650000	
DRW/DRH CLIP M	10	1220260000	
SDIK SLIM PH2 X 100	1	2749660000	
SDIK PH2 X 100	1	2749900000	
SDK PH2 X 100	1	2749420000	

**Note**

Further accessories can be found on the article at [eshop.weidmueller.com](http://eshop.weidmueller.com)



# Sensor isolation

## Compact and powerful solid-state relays for isolation sensor signals

**C** In order to reliably decouple sensor signals from the field, space-saving and fast-switching coupling elements are required. We offer special solid-state relays for sensor isolation, as well as relay modules with gold-plated contacts for reliable switching of small currents and voltages, as they typically occur when switching sensor signals.

### **Solid-state relay for sensor isolation**

As there is often a high number of switching cycles in sensor isolation, it makes sense to use solid-state relays. They have no mechanical wear and therefore work reliably in the long term. Our solid-state relays are extremely compact and, thanks to suitable accessories, enable quick installation. By using TERMSERIES interface adapters in conjunction with pre-assembled cables, the wiring time can be reduced further.

### **Electromechanical relays with gold contacts**

In applications where sensor isolation is only carried out at longer intervals and with low power (< 30 V/10 mA), oxide layers can form on the contacts. This usually occurs in applications where signals are forwarded to control inputs or PLC systems. Due to the low loads, there is not enough light arcing at the contacts to remove the oxide layer during switching. Therefore, relay modules with oxidation-resistant gold contacts are used.



Visit our website for more information  
[www.weidmueller.com/si](http://www.weidmueller.com/si)

**Solid-state relays 5...48 V DC / 100 mA**

**Output versions**

- Space-saving 6.1 mm width
- Plug-in cross-connections
- Screw and PUSH IN wire connection
- Enclosed design



**5 V DC**

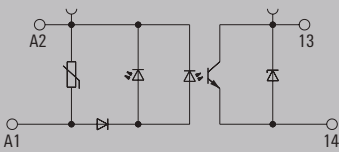

**12...220 DC**

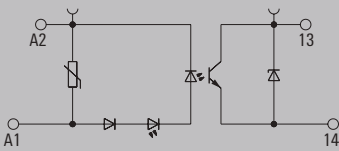

**24...230 V AC**

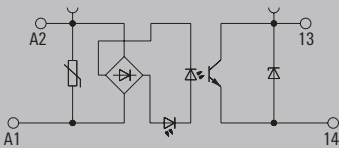

**Technical data**

Load side	
Rated switching voltage	5...48 V DC
Continuous current	0.1 A
Inrush current	
Solid-state type	Transistor
Voltage drop at max. load	<1 V
Leakage current	<10 µA
Protective circuit, load side	Free-wheeling diode
Short-circuit-proof / Protective circuit, load side	No / Free-wheeling diode
General data	
Ambient temperature (operational)	-20 °C...60 °C
Storage temperature	-40 °C...80 °C
Humidity	5-95% relative humidity, T <sub>0</sub> = 40°C, without condensation
Approvals	CE, cULus
Insulation coordinates	
Rated voltage	300 V
Impulse withstand voltage	4 kV (1.2/50 µs)
Dielectric strength for control side - load side	1.2 kV <sub>eff</sub> / 1 min.
Dielectric strength to mounting rail	
Clearance and creepage distances for control side - load side	> 3 mm
Overvoltage category	III
Pollution degree	2

Dimensions	Screw connection	PUSH IN connection
Clamping range (nominal / min. / max.)	mm <sup>2</sup> 2.5 / 0.5 / 4	1.5 / 0.5 / 2.5
Depth x width x height	mm 55 / 6.1 / 74.4	55 / 6.1 / 79.4

**Note** Accessories and dimensioned drawings: refer to the TERMOPTO Accessories page.

**Applications**

The **TERMOPTO** opto module is used in industrial applications in which electrical isolation and signal conditioning without switching amplification is sufficient.

The compact design in terminal-block format saves space on the rail and offers the option of a pluggable cross connection.

The choice between 10 input voltages and 3 output voltages, as well as screw or PUSH IN connection technology, gives 60 variations for different applications.

The integrated protective circuit ensures sufficient protection in applications with resistive, as well as slightly inductive and capacitive loads. For purely inductive, capacitive or comparable loads with high switch-on and switch-off peaks, such as solenoid valves or filament lamps, ensure that the module is dimensioned appropriately or an additional safeguard is used.

e.g. electrical isolation

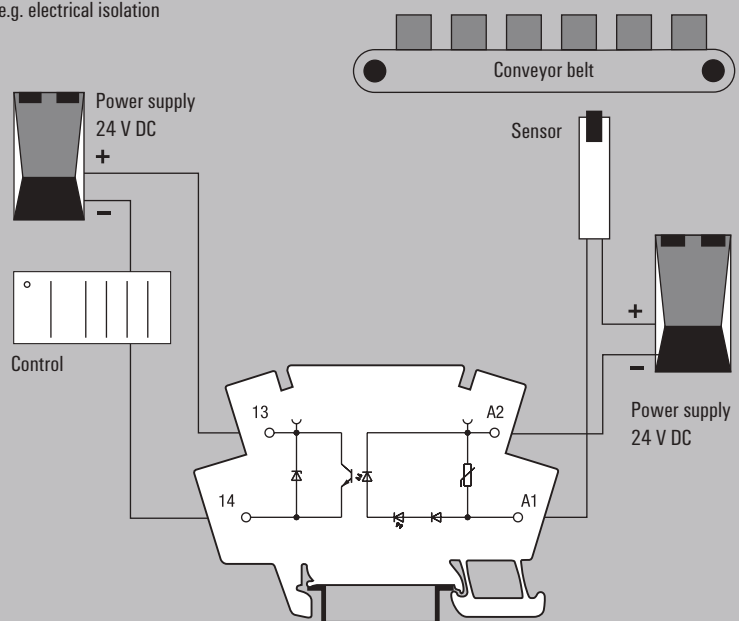

## Solid-state relays 5...48 V DC / 100 mA

## Output versions

## Ordering data

	5 V DC	12 V DC	24 V DC	48...60 V DC	110 V DC
<b>Control side</b>					
Rated control voltage	5 V DC $\pm 20\%$	12 V DC $\pm 20\%$	24 V DC $\pm 20\%$	48...60 V DC $\pm 20\%$	110 V DC $\pm 20\%$
Nominal control current	7.7 mA DC	7.8 mA DC	7 mA DC	4.3 mA DC	2.6 mA DC
Power rating	<40 mW	<95 mW	$\leq 170$ mW	<200 mW	<280 mW
max. switching frequency (DC control voltage)	3000 Hz	3000 Hz	3000 Hz	500 Hz	500 Hz
max. switching frequency (AC control voltage)					
Status indicator	Green LED	Green LED	Green LED	Green LED	Green LED
Protective circuit	Varistor, Reverse polarity protection	Varistor, Reverse polarity protection	Varistor, Reverse polarity protection	Varistor, Reverse polarity protection	Varistor, Reverse polarity protection

## Ordering data

Screw connection	Type	TOS 5VDC/48VDC 0,1A	TOS 12VDC/48VDC 0,1A	TOS 24VDC/48VDC 0,1A	TOS 48-60VDC/48VDC 0,1A	TOS 110VDC/48VDC 0,1A
	Order No.	8950700000	8950710000	8950720000	8950730000	8950740000
PUSH IN connection	Type	TOP 5VDC/48VDC 0,1A	TOP 12VDC/48VDC 0,1A	TOP 24VDC/48VDC 0,1A	TOP 48-60VDC/48VDC 0,1A	TOP 110VDC/48VDC 0,1A
	Order No.	8950760000	8950770000	8950780000	8950790000	8950800000
<b>Note</b>						

## Ordering data

	220 V DC	24 V AC	48...60 V AC	120 V AC	230 V AC
<b>Control side</b>					
Rated control voltage	220 V DC $+10\%$ / $-15\%$	24 V AC $\pm 20\%$	48...60 V AC $\pm 20\%$	120 V AC $\pm 20\%$	230 V AC $+10\%$ / $-20\%$
Nominal control current	1.65 mA DC	7.4 mA AC	4.3 mA AC	2.9 mA AC	1.75 mA AC
Power rating	$\leq 360$ mW	<0.18 VA	$\leq 0.2$ VA	$\leq 0.3$ VA	$\leq 0.4$ VA
max. switching frequency (DC control voltage)	500 Hz				
max. switching frequency (AC control voltage)		10 Hz	10 Hz	10 Hz	10 Hz
Status indicator	Green LED	Green LED	Green LED	Green LED	Green LED
Protective circuit	Varistor, Reverse polarity protection	Varistor	Varistor	Varistor	Varistor

## Ordering data

Screw connection	Type	TOS 220VDC/48VDC 0,1A	TOS 24VAC/48VDC 0,1A	TOS 48-60VAC/48VDC 0,1A	TOS 120VAC/48VDC 0,1A	TOS 230VAC/48VDC 0,1A
	Order No.	8950750000	8950820000	8950830000	8950840000	8950850000
PUSH IN connection	Type	TOP 220VDC/48VDC 0,1A	TOP 24VAC/48VDC 0,1A	TOP 48-60VAC/48VDC 0,1A	TOP 120VAC/48VDC 0,1A	TOP 230VAC/48VDC 0,1A
	Order No.	8950810000	8950860000	8950870000	8950880000	8950890000
<b>Note</b>						

**Solid-state relays, 5...48 V DC / 500 mA**

**Output versions**

- Space-saving 6.1 mm width
- Plug-in cross-connections
- Screw and PUSH IN wire connection
- Enclosed design



**Technical data**

Load side	
Rated switching voltage	5...48 V DC
Continuous current	0.5 A
Inrush current	
Solid-state type	Transistor
Voltage drop at max. load	<1 V
Leakage current	<10 µA
Protective circuit, load side	Free-wheeling diode
Short-circuit-proof / Protective circuit, load side	No / Free-wheeling diode
General data	
Ambient temperature (operational)	-20 °C...60 °C
Storage temperature	-40 °C...80 °C
Humidity	5-95% relative humidity, T <sub>90</sub> = 40°C, without condensation
Approvals	CE, cULus
Insulation coordinates	
Rated voltage	300 V
Impulse withstand voltage	4 kV (1.2/50 µs)
Dielectric strength for control side - load side	1.2 kV <sub>eff</sub> / 1 min.
Dielectric strength to mounting rail	
Clearance and creepage distances for control side - load side	> 3 mm
Overvoltage category	III
Pollution degree	2

Dimensions	Screw connection	PUSH IN connection
Clamping range (nominal / min. / max.)	mm <sup>2</sup> 2.5 / 0.5 / 4	1.5 / 0.5 / 2.5
Depth x width x height	mm 55 / 6.1 / 74.4	55 / 6.1 / 79.4

**Note** Accessories and dimensioned drawings: refer to the TERMOPTO Accessories page.

**5 V DC**

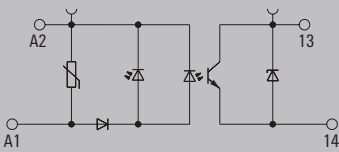

**12...220 DC**

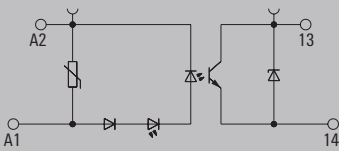

**24...230 V AC**

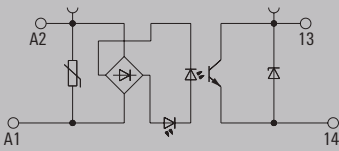

**Applications**

The **TERMOPTO** opto module is used in industrial applications in which electrical isolation and signal conditioning without switching amplification is sufficient.

The compact design in terminal-block format saves space on the rail and offers the option of a pluggable cross connection.

The choice between 10 input voltages and 3 output voltages, as well as screw or PUSH IN connection technology, gives 60 variations for different applications.

The integrated protective circuit ensures sufficient protection in applications with resistive, as well as slightly inductive and capacitive loads. For purely inductive, capacitive or comparable loads with high switch-on and switch-off peaks, such as solenoid valves or filament lamps, ensure that the module is dimensioned appropriately or an additional safeguard is used.

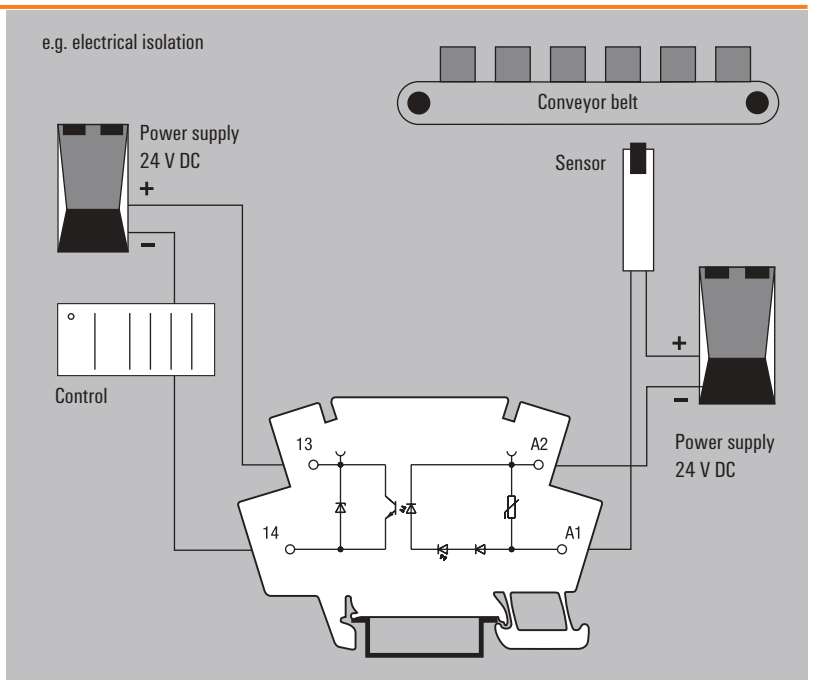

## Solid-state relays, 5...48 V DC / 500 mA

## Output versions

## Ordering data

	5 V DC	12 V DC	24 V DC	48...60 V DC	110 V DC
<b>Control side</b>					
Rated control voltage	5 V DC $\pm 20\%$	12 V DC $\pm 20\%$	24 V DC $\pm 20\%$	48...60 V DC $\pm 20\%$	110 V DC $\pm 20\%$
Nominal control current	7.7 mA DC	7.8 mA DC	7 mA DC	4.3 mA DC	2.6 mA DC
Power rating	<40 mW	<95 mW	$\leq 170$ mW	$\leq 200$ mW	$\leq 280$ mW
max. switching frequency (DC control voltage)	200 Hz	200 Hz	200 Hz	200 Hz	200 Hz
max. switching frequency (AC control voltage)					
Status indicator	Green LED	Green LED	Green LED	Green LED	Green LED
Protective circuit	Varistor, Reverse polarity protection	Varistor, Reverse polarity protection	Varistor, Reverse polarity protection	Varistor, Reverse polarity protection	Varistor, Reverse polarity protection

## Ordering data

Screw connection	Type	TOS 5VDC/48VDC 0,5A	TOS 12VDC/48VDC 0,5A	TOS 24VDC/48VDC 0,5A	TOS 48-60VDC/48VDC 0,5A	TOS 110VDC/48VDC 0,5A
	Order No.	8950900000	8950910000	8950920000	8950930000	8950940000
PUSH IN connection	Type	TOP 5VDC/48VDC 0,5A	TOP 12VDC/48VDC 0,5A	TOP 24VDC/48VDC 0,5A	TOP 48-60VDC/48VDC 0,5A	TOP 110VDC/48VDC 0,5A
	Order No.	8950960000	8950970000	8950980000	8950990000	8951000000
<b>Note</b>						

## Ordering data

	220 V DC	24 V AC	48...60 V AC	120 V AC	230 V AC
<b>Control side</b>					
Rated control voltage	220 V DC $+10\%$ / $-15\%$	24 V AC $\pm 20\%$	48...60 V AC $\pm 20\%$	120 V AC $\pm 20\%$	230 V AC $+10\%$ / $-20\%$
Nominal control current	1.65 mA DC	7.4 mA AC	4.3 mA AC	2.9 mA AC	1.75 mA AC
Power rating	$\leq 360$ mW	<0.18 VA	$\leq 0.2$ VA	$\leq 0.3$ VA	$\leq 0.4$ VA
max. switching frequency (DC control voltage)	200 Hz				
max. switching frequency (AC control voltage)		10 Hz	10 Hz	10 Hz	10 Hz
Status indicator	Green LED	Green LED	Green LED	Green LED	Green LED
Protective circuit	Varistor, Reverse polarity protection	Varistor	Varistor	Varistor	Varistor

## Ordering data

Screw connection	Type	TOS 220VDC/48VDC 0,5A	TOS 24VAC/48VDC 0,5A	TOS 48-60VAC/48VDC 0,5A	TOS 120VAC/48VDC 0,5A	TOS 230VAC/48VDC 0,5A
	Order No.	8950950000	8951020000	8951030000	8951040000	8951050000
PUSH IN connection	Type	TOP 220VDC/48VDC 0,5A	TOP 24VAC/48VDC 0,5A	TOP 48-60VAC/48VDC 0,5A	TOP 120VAC/48VDC 0,5A	TOP 230VAC/48VDC 0,5A
	Order No.	8951010000	8951060000	8951070000	8951080000	8951090000
<b>Note</b>						

**Solid-state relays 24...230 V AC / 100 mA**

**Output versions**

- Space-saving 6.1 mm width
- Plug-in cross-connections
- Screw and PUSH IN wire connection
- Enclosed design

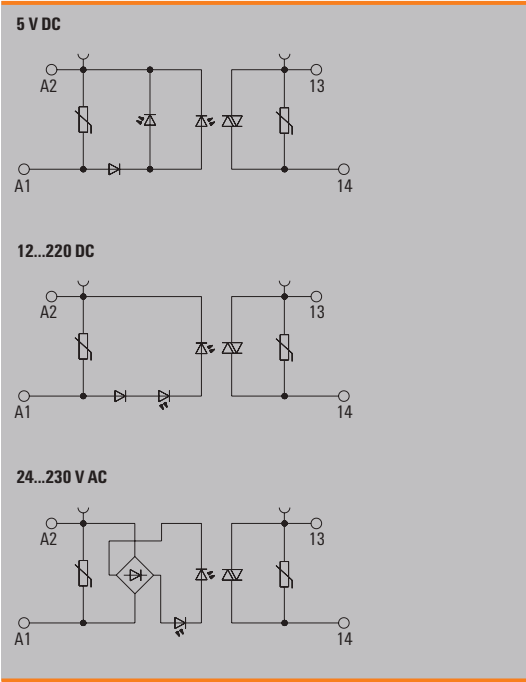

**Technical data**

Load side		
Rated switching voltage	24...230 V AC	
Continuous current	100 mA	
Inrush current		
Solid-state type	Triac (zero-cross switch)	
Voltage drop at max. load	<1.8 V	
Leakage current	<1 mA	
Protective circuit, load side	Varistor, RC element	
Short-circuit-proof / Protective circuit, load side	No / Varistor, RC element	
General data		
Ambient temperature (operational)	-20 °C...60 °C	
Storage temperature	-40 °C...80 °C	
Humidity	5-95% relative humidity, T <sub>0</sub> = 40°C, without condensation	
Approvals	CE, cULus	
Insulation coordinates		
Rated voltage	300 V	
Impulse withstand voltage	4 kV (1.2/50 µs)	
Dielectric strength for control side - load side	1.2 kV <sub>eff</sub> / 1 min.	
Dielectric strength to mounting rail		
Clearance and creepage distances for control side - load side	> 3 mm	
Overvoltage category	III	
Pollution degree	2	
Dimensions		
Clamping range (nominal / min. / max.)	Screw connection	2.5 / 0.5 / 4
	PUSH IN	1.5 / 0.5 / 2.5
Depth x width x height	mm	55 / 6.1 / 74.4
Note	Accessories and dimensioned drawings: refer to the TERMOPTO Accessories page.	

**Applications**

The **TERMOPTO** opto module is used in industrial applications in which electrical isolation and signal conditioning without switching amplification is sufficient.

The compact design in terminal-block format saves space on the rail and offers the option of a pluggable cross connection.

The choice between 10 input voltages and 3 output voltages as well as between screw or PUSH IN connection technology gives 60 variations for different applications.

The integrated protective circuit ensures sufficient protection in applications with resistive as well as slightly inductive and capacitive loads. For purely inductive, capacitive or comparable loads with high switch-on and switch-off peaks, such as solenoid valves or filament lamps, ensure that the module is dimensioned appropriately or an additional safeguard is used.

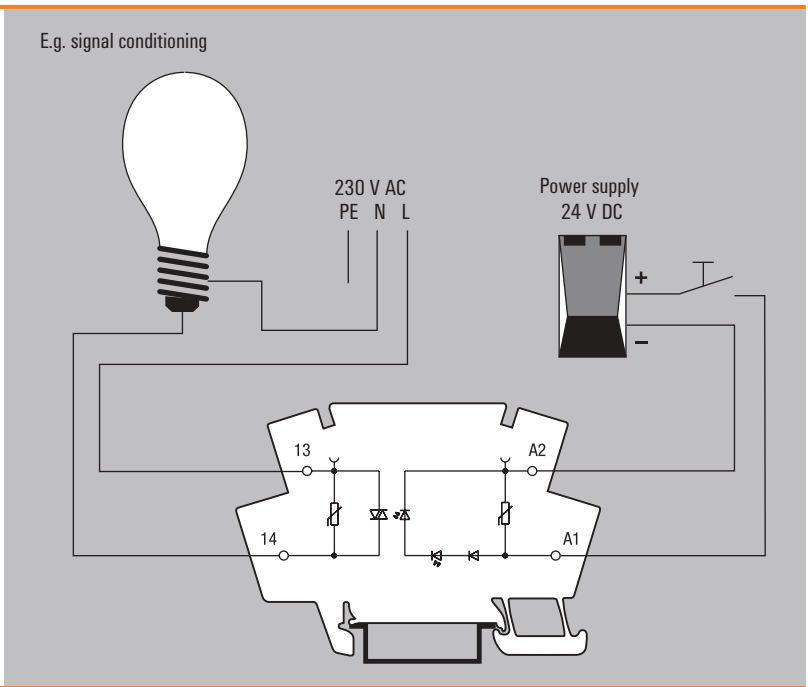

## Solid-state relays 24...230 V AC / 100 mA

## Output versions

## Ordering data

	5 V DC	12 V DC	24 V DC	48...60 V DC	110 V DC
<b>Control side</b>					
Rated control voltage	5 V DC $\pm 20\%$	12 V DC $\pm 20\%$	24 V DC $\pm 20\%$	48...60 V DC $\pm 20\%$	110 V DC $\pm 20\%$
Nominal control current	7.8 mA DC	3.6 mA DC	3.6 mA DC	3.7 mA DC	3.6 mA DC
Power rating	<40 mW	<45 mW	$\leq 80$ mW	$\leq 170$ mW	$\leq 360$ mW
max. switching frequency (DC control voltage)	10 Hz	10 Hz	10 Hz	10 Hz	10 Hz
max. switching frequency (AC control voltage)					
Status indicator	Green LED	Green LED	Green LED	Green LED	Green LED
Protective circuit	Varistor, Reverse polarity protection	Varistor, Reverse polarity protection	Varistor, Reverse polarity protection	Varistor, Reverse polarity protection	Varistor, Reverse polarity protection

## Ordering data

Screw connection	Type	TOS 5VDC/230VAC 0,1A	TOS 12VDC/230VAC 0,1A	TOS 24VDC/230VAC 0,1A	TOS 48-60VDC/230VAC 0,1A	TOS 110VDC/230VAC 0,1A
	Order No.	8951100000	8951110000	8951120000	8951130000	8951140000
PUSH IN connection	Type	TOP 5VDC/230VAC 0,1A	TOP 12VDC/230VAC 0,1A	TOP 24VDC/230VAC 0,1A	TOP 48-60VDC/230VAC 0,1A	TOP 110VDC/230VAC 0,1A
	Order No.	8951160000	8951170000	8951180000	8951190000	8951200000
<b>Note</b>						

## Ordering data

	220 V DC	24 V AC	48...60 V AC	120 V AC	230 V AC
<b>Control side</b>					
Rated control voltage	220 V DC $+10\%$ / $-15\%$	24 V AC $\pm 20\%$	48...60 V AC $\pm 20\%$	120 V AC $\pm 20\%$	230 V AC $+10\%$ / $-20\%$
Nominal control current	2.9 mA DC	8.8 mA AC	6.4 mA AC	8.5 mA AC	7.7 mA AC
Power rating	$\leq 640$ mW	$\leq 0.2$ VA	$\leq 0.3$ VA	$\leq 1$ VA	$\leq 1.7$ VA
max. switching frequency (DC control voltage)	10 Hz				
max. switching frequency (AC control voltage)		10 Hz	10 Hz	10 Hz	10 Hz
Status indicator	Green LED	Green LED	Green LED	Green LED	Green LED
Protective circuit	Varistor, Reverse polarity protection	Varistor	Varistor	Varistor	Varistor

## Ordering data

Screw connection	Type	TOS 220VDC/230VAC 0,1A	TOS 24VAC/230VAC 0,1A	TOS 48-60VAC/230VAC 0,1A	TOS 120VAC/230VAC 0,1A	TOS 230VAC/230VAC 0,1A
	Order No.	8951150000	8951220000	8951230000	8951240000	8951250000
PUSH IN connection	Type	TOP 220VDC/230VAC 0,1A	TOP 24VAC/230VAC 0,1A	TOP 48-60VAC/230VAC 0,1A	TOP 120VAC/230VAC 0,1A	TOP 230VAC/230VAC 0,1A
	Order No.	8951210000	8951260000	8951270000	8951280000	8951290000
<b>Note</b>						

**Solid-state relays, 5...48 V DC / 500 mA**

**Output versions with RC element**

- Space-saving 6.1 mm width
- Plug-in cross-connections
- Screw and PUSH IN wire connection
- Enclosed design
- RC input circuitry for improved interference immunity



**120 V...230 V AC**

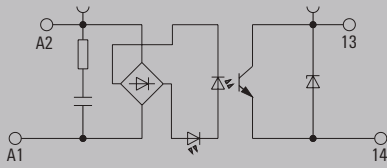

**Technical data**

Load side	
Rated switching voltage	5...48 V DC
Continuous current	0.5 A
Inrush current	
Solid-state type	Transistor
Voltage drop at max. load	<1 V
Leakage current	<10 µA
Protective circuit, load side	Diode circuit
Short-circuit-proof / Protective circuit, load side	No / Diode circuit
General data	
Ambient temperature (operational)	-20 °C...60 °C
Storage temperature	-40 °C...80 °C
Humidity	5-95% relative humidity, T <sub>0</sub> = 40°C, without condensation
Approvals	CE, cULus
Insulation coordinates	
Rated voltage	300 V
Impulse withstand voltage	4 kV (1.2/50 µs)
Dielectric strength for control side - load side	1.2 kV <sub>eff</sub> / 1 min.
Dielectric strength to mounting rail	
Clearance and creepage distances for control side - load side	> 3 mm
Overvoltage category	III
Pollution degree	2

Dimensions	Screw connection	PUSH IN connection
Clamping range (nominal / min. / max.)	mm <sup>2</sup> 2.5 / 0.5 / 4	1.5 / 0.5 / 2.5
Depth x width x height	mm 55 / 6.1 / 74.4	55 / 6.1 / 79.4

**Note** Accessories and dimensioned drawings: refer to the TERMOPTO Accessories page.

**Ordering data**

	120 V AC	230 V AC
<b>Control side</b>		
Rated control voltage	120 V AC ±20 %	230 V AC +10 %/-15 %
Nominal control current	6.4 mA AC	6.4 mA AC
Power rating	≤ 0.61 VA	≤ 1.5 VA
max. switching frequency (DC control voltage)		
max. switching frequency (AC control voltage)	10 Hz	10 Hz
Status indicator	Green LED	Green LED
Protective circuit	RC element	RC element

Ordering data			
Screw connection	Type	TOS 120VAC/48VDC 0.5A RC	TOS 230VAC/48VDC 0.5A RC
	Order No.	<b>1180290000</b>	<b>1189270000</b>
PUSH IN connection	Type	TOP 120VAC/48VDC 0.5A RC	TOP 230VAC/48VDC 0.5A RC
	Order No.	<b>1188830000</b>	<b>1189260000</b>
<b>Note</b>			



**1 CO contact with hard gold-plated contacts**  
**AC/DC/UC coil**

- Space saving, just 6.4 mm modular width
- AgNi contact with gold plating
- PUSH IN and screw connection

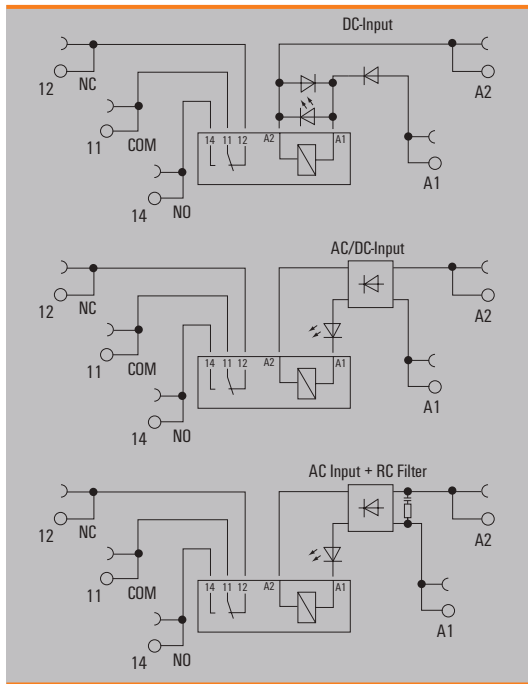
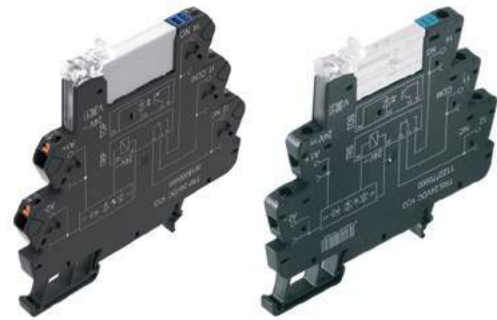

**Technical data**

Load side	
Rated switching voltage / Continuous current	250 V AC / 6 A
Max. switching voltage, AC	250 V
Inrush current	20 A / 20 ms
Min. switching power	1 mA @ 1 V
Contact type	1 CO contact (AgNi gold-plated)
Mechanical service life	5 x 10 <sup>6</sup> switching cycles
Max. switching frequency at rated load	0.1 Hz
General data	
Ambient temperature (operational)	-40 °C...60 °C
Storage temperature	-40 °C...85 °C
Humidity	5-95% relative humidity, T <sub>0</sub> = 40°C, without condensation
Approvals	CE; cULus; DETNORVER; UKCA
Insulation coordinates	
Rated voltage	300 V
Impulse withstand voltage	6 kV (1.2/50 µs)
Dielectric strength for control side - load side	4 kV <sub>eff</sub> / 1 Min.
Dielectric strength of neighbouring contacts	
Dielectric strength to mounting rail	4 kV <sub>eff</sub> / 1 Min.
Clearance and creepage distances for control side - load side	≥ 6 mm
Overvoltage category	III
Pollution degree	2
Dimensions	
Clamping range (nominal / min. / max.)	mm <sup>2</sup> 1.5 / 0.14 / 2.5
Depth x width x height	mm 87.8 / 6.4 / 89.4
	mm 87.8 / 6.4 / 89.6
Note	
Accessories and dimensional drawings: refer to the TERMSERIES Accessories page. Further approvals and technical data can be found at <a href="http://eshop.weidmueller.com">eshop.weidmueller.com</a>	

**Applications**

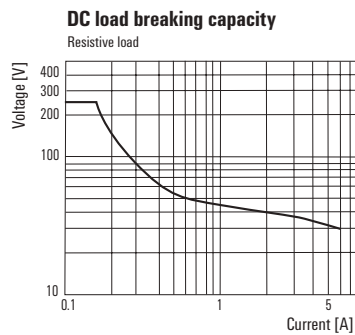
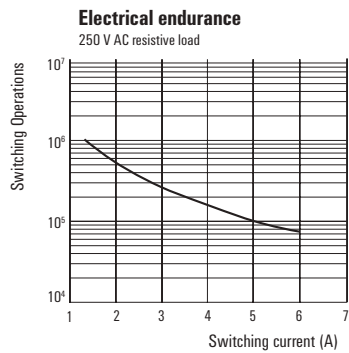

1 CO contact with hard gold-plated contacts  
AC/DC/UC coil

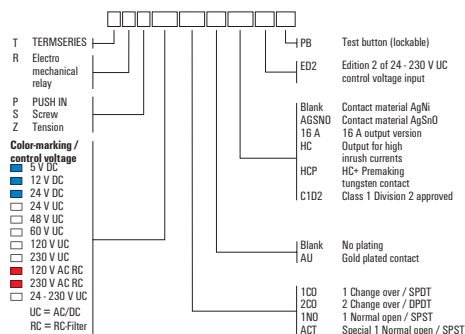

Ordering data

Control side	5 V DC	12 V DC	24 V DC	24 V UC	48 V UC
Rated control voltage	5 V DC ± 20 %	12 V DC ± 20 %	24 V DC ± 20 %	24 V UC ± 10 %	48 V UC ± 10 %
Rated current AC / DC	/ 33 mA	/ 18 mA	/ 11.5 mA	11.7 mA / 6.4 mA	8 mA / 7 mA
Power rating	170 mW	210 mW	280 mW	270 mVA / 154 mW	340 mW / 0.4 VA
Status indicator	Green LED	Green LED	Green LED	Green LED	Green LED
Protective circuit	Free-wheeling diode, Reverse polarity protection	Free-wheeling diode, Reverse polarity protection	Free-wheeling diode, Reverse polarity protection	Rectifier	Rectifier

Ordering data	5 V DC	12 V DC	24 V DC	24 V UC	48 V UC
PUSH IN connection Type	TRP 5VDC 1CO AU	TRP 12VDC 1CO AU	TRP 24VDC 1CO AU	TRP 24VUC 1CO AU	TRP 48VUC 1CO AU
Order No.	2618060000	2618120000	2618110000	2618160000	2618170000
Screw connection Type	TRS 5VDC 1CO AU	TRS 12VDC 1CO AU	TRS 24VDC 1CO AU	TRS 24VUC 1CO AU	TRS 48VUC 1CO AU
Order No.	1122980000	1122990000	1123000000	1123010000	1123020000
Note					

Ordering data

Control side	60 V UC	120 V UC	230 V UC	120 V AC RC	230 V AC RC
Rated control voltage	60 V UC ± 10 %	120 V UC ± 10 %	230 V UC ± 10 %	120 V AC ± 10 %	230 V AC ± 10 %
Rated current AC / DC	4,8 mA / 2,8 mA	4 mA / 3,5 mA	3,5 mA / 2,9 mA	7 mA /	8,5 mA /
Power rating	170 mW, 290 mVA	0,48 VA, 420 mW	670 mW, 805 mVA	840 mVA	2 VA
Status indicator	Green LED	Green LED	Green LED	Green LED	Green LED
Protective circuit	Rectifier	Rectifier	Rectifier	Rectifier, RC element	Rectifier, RC element

Ordering data	60 V UC	120 V UC	230 V UC	120 V AC RC	230 V AC RC
PUSH IN connection Type	TRP 60VUC 1CO AU	TRP 120VUC 1CO AU	TRP 230VUC 1CO AU	TRP 120VAC RC 1CO AU	TRP 230VAC RC 1CO AU
Order No.	2618070000	2618080000	2618210000	2618030000	2617950000
Screw connection Type	TRS 60VUC 1CO AU	TRS 120VUC 1CO AU	TRS 230VUC 1CO AU	TRS 120VAC RC 1CO AU	TRS 230VAC RC 1CO AU
Order No.	1123030000	1123040000	1123050000	1123070000	1123080000
Note					

**1 CO contact with hard gold-plated contacts**  
**multi-voltage input**

- Space saving, just 6.4 mm modular width
- AgNi contact with gold plating
- PUSH IN and screw connection
- Multi-voltage input: 24...230 V UC in one module

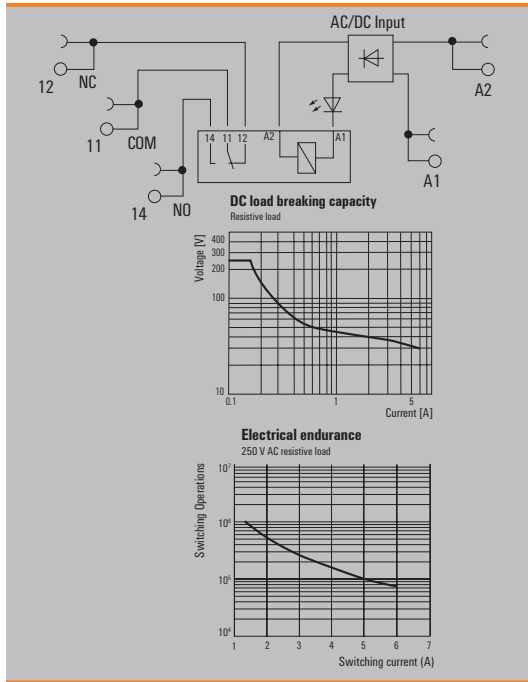

**Technical data**

Load side		
Rated switching voltage / Continuous current	250 V AC / 6 A	
Max. switching voltage, AC	250 V	
Inrush current	20 A / 20 ms	
Min. switching power	1 mA @ 1 V	
Contact type	1 CO contact (AgNi gold-plated)	
Mechanical service life	5 x 10 <sup>6</sup> switching cycles	
Max. switching frequency at rated load	0.1 Hz	
General data		
Ambient temperature (operational)	-40 °C...60 °C	
Storage temperature	-40 °C...85 °C	
Humidity	5-95% relative humidity, T <sub>90</sub> = 40°C, without condensation	
Approvals	CE; cULus; DETNORVER; UKCA	
Insulation coordinates		
Rated voltage	300 V	
Impulse withstand voltage		
Dielectric strength for control side - load side	3.51 kV <sub>eff</sub> / 1 min.	
Dielectric strength of neighbouring contacts		
Dielectric strength to mounting rail	3.51 kV <sub>eff</sub> / 1 min.	
Clearance and creepage distances for control side - load side	≥ 6 mm	
Overvoltage category	III	
Pollution degree	2	
Dimensions		
	<b>PUSH IN</b>	<b>Screw connection</b>
Clamping range (nominal / min. / max.)	mm <sup>2</sup> 1.5 / 0.14 / 2.5	1.5 / 0.14 / 2.5
Depth x width x height	mm 87.8 / 6.4 / 89.4	87.8 / 6.4 / 89.6
Note		
Accessories and dimensional drawings: refer to the TERMSERIES Accessories page. Further approvals and technical data can be found at <a href="http://eshop.weidmueller.com">eshop.weidmueller.com</a>		

**Ordering data**

Control side	24 V - 230 V UC
Rated control voltage	24...230 V UC ± 10 %
Rated current AC / DC	19.0 mA @ 24 V AC, 3.0 mA @ 230 V AC / 11.0 mA @ 24 V DC, 1.1 mA @ 230 V DC
Power rating	265 mW @ 24 V DC, 255 mW @ 230 V DC, 455 mVA @ 24 V AC, 690 mVA @ 230 V AC
Status indicator	Green LED
Protective circuit	Rectifier
Approvals	CE; cULus; DETNORVER; UKCA

Ordering data	
PUSH IN connection	Type TRP 24-230VUC 1CO AU ED2
Order No.	<b>2663020000</b>
Screw connection	Type TRS 24-230VUC 1CO AU ED2
Order No.	<b>2662860000</b>
Note	

**2 CO contact with hard gold-plated contacts**  
**multi-voltage input**

- Space saving, just 12.8 mm modular width
- AgNi contact
- PUSH IN and screw connection
- Multi-voltage input: 24...230 V UC in one module

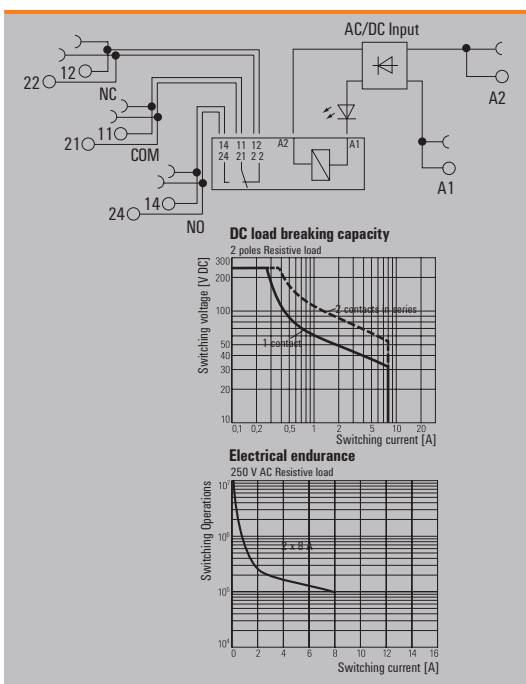

**Technical data**

Load side	
Rated switching voltage / Continuous current	250 V AC / 8 A
Max. switching voltage, AC	250 V
Inrush current	15 A / 4 s
Min. switching power	1 mA @ 1 V
Contact type	2 CO contact (AgNi gold-plated)
Mechanical service life	30 x 10 <sup>6</sup> switching cycles
Max. switching frequency at rated load	0.1 Hz
General data	
Ambient temperature (operational)	-40 °C...60 °C
Storage temperature	-40 °C...85 °C
Humidity	5-95% relative humidity, T <sub>0</sub> = 40°C, without condensation
Approvals	CE; cULus; DETNORVER; UKCA
Insulation coordinates	
Rated voltage	300 V
Impulse withstand voltage	
Dielectric strength for control side - load side	3.51 kV <sub>eff</sub> / 1 min.
Dielectric strength of neighbouring contacts	
Dielectric strength to mounting rail	3.51 kV <sub>eff</sub> / 1 min.
Clearance and creepage distances for control side - load side	≥ 6 mm
Overvoltage category	III
Pollution degree	2
Dimensions	
Clamping range (nominal / min. / max.)	mm <sup>2</sup> 1.5 / 0.14 / 2.5
Depth x width x height	mm 87.8 / 12.8 / 89.4
	mm 87.8 / 12.8 / 89.6
Note	
Accessories and dimensional drawings: refer to the TERMSERIES Accessories page. Further approvals and technical data can be found at <a href="http://eshop.weidmueller.com">eshop.weidmueller.com</a>	

**Ordering data**

Control side	
Rated control voltage	24...230 V UC ± 10 %
Rated current AC / DC	23.5 mA @ 24 V AC, 4.5 mA @ 230 V AC / 22.5 mA @ 24 V DC, 2.0 mA @ 230 V DC
Power rating	540 mW @ 24 V DC, 460 mW @ 230 V DC, 565 mVA @ 24 V AC, 1.0 VA @ 230 V AC
Status indicator	Green LED
Protective circuit	Rectifier
Approvals	CE; cULus; DETNORVER; UKCA

Ordering data	
PUSH IN connection	Type TRP 24-230VUC 2CO AU ED2
Order No.	<b>2663050000</b>
Screw connection	Type TRS 24-230VUC 2CO AU ED2
Order No.	<b>2662890000</b>
Note	

**2 CO contact with hard gold-plated contacts**  
**AC/DC/UC coil**

- Space saving, just 12.8 mm modular width
- AgNi contact with gold plating
- PUSH IN and screw connection

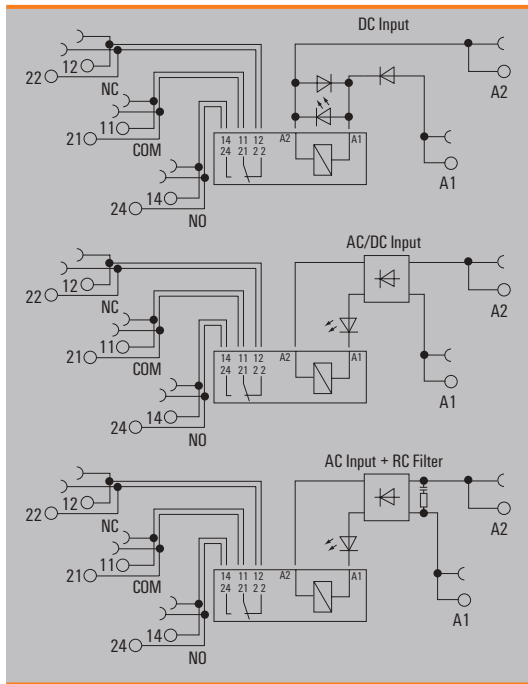

**Technical data**

Load side	
Rated switching voltage / Continuous current	250 V AC / 8 A
Max. switching voltage, AC	250 V
Inrush current	15 A / 4 s
Min. switching power	1 mA @ 1 V
Contact type	2 CO contact (AgNi gold-plated)
Mechanical service life	30 x 10 <sup>6</sup> switching cycles
Max. switching frequency at rated load	0.1 Hz
General data	
Ambient temperature (operational)	-40 °C...60 °C
Storage temperature	-40 °C...85 °C
Humidity	5-95% relative humidity, T <sub>0</sub> = 40°C, without condensation
Approvals	CE; cULus; DETNORVER; UKCA
Insulation coordinates	
Rated voltage	300 V
Impulse withstand voltage	6 kV (1.2/50 µs)
Dielectric strength for control side - load side	3.51 kV <sub>eff</sub> / 1 min.
Dielectric strength of neighbouring contacts	2.5 kV <sub>eff</sub> / 1 Min.
Dielectric strength to mounting rail	4 kV <sub>eff</sub> / 1 Min.
Clearance and creepage distances for control side - load side	≥ 6 mm
Overvoltage category	III
Pollution degree	2

Dimensions	PUSH IN		Screw connection
Clamping range (nominal / min. / max.)	mm <sup>2</sup>	1.5 / 0.14 / 2.5	1.5 / 0.14 / 2.5
Depth x width x height	mm	87.8 / 12.8 / 89.4	87.8 / 12.8 / 89.6
<b>Note</b>	Accessories and dimensional drawings: refer to the TERMSERIES Accessories page. Further approvals and technical data can be found at <a href="http://eshop.weidmueller.com">eshop.weidmueller.com</a>		

**Applications**

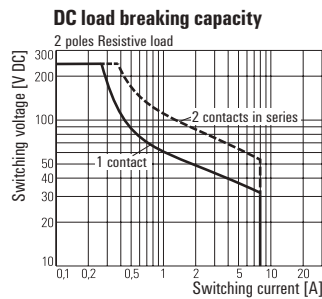
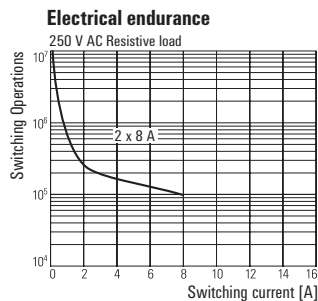

2 CO contact with hard gold-plated contacts  
AC/DC/UC coil

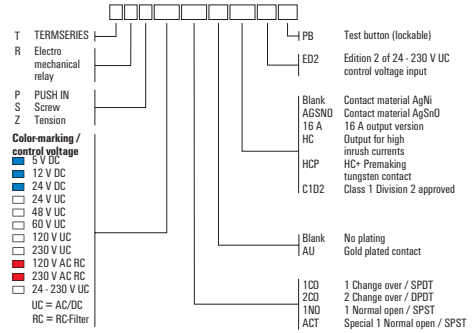

Ordering data

Control side	5 V DC	12 V DC	24 V DC	24 V UC	48 V UC
Rated control voltage	5 V DC ± 20 %	12 V DC ± 20 %	24 V DC ± 20 %	24 V UC ± 10 %	48 V UC ± 10 %
Rated current AC / DC	/ 70 mA	/ 33 mA	/ 20.5 mA	16 mA / 14 mA	9 mA / 7 mA
Power rating	400 mW	400 mW	495 mW	390 mVA / 350 mW	340 mW / 0.4 VA
Status indicator	Green LED	Green LED	Green LED	Green LED	Green LED
Protective circuit	Free-wheeling diode, Reverse polarity protection	Free-wheeling diode, Reverse polarity protection	Free-wheeling diode, Reverse polarity protection	Rectifier	Rectifier

Ordering data					
PUSH IN connection Type	TRP 5VDC 2CO AU	TRP 12VDC 2CO AU	TRP 24VDC 2CO AU	TRP 24VUC 2CO AU	TRP 48VUC 2CO AU
Order No.	2618580000	2618310000	2618530000	2618540000	2618560000
Screw connection Type	TRS 5VDC 2CO AU	TRS 12VDC 2CO AU	TRS 24VDC 2CO AU	TRS 24VUC 2CO AU	TRS 48VUC 2CO AU
Order No.	1123710000	1123720000	1123730000	1123740000	1123750000
Note					

Ordering data

Control side	60 V UC	120 V UC	230 V UC	120 V AC RC	230 V AC RC
Rated control voltage	60 V UC ± 10 %	120 V UC ± 10 %	230 V UC ± 5 %	120 V AC ± 10 %	230 V AC ± 5 %
Rated current AC / DC	8.3 mA / 6.0 mA	3.5 mA / 3.5 mA	5.5 mA / 4.4 mA	5.5 mA /	8.8 mA /
Power rating	360 mW, 500 mVA	420 mVA / 420 mW	1 W, 1.2 VA	0.6 VA	2.1 VA
Status indicator	Green LED	Green LED	Green LED	Green LED	Green LED
Protective circuit	Rectifier	Rectifier	Rectifier	Rectifier, RC element	Rectifier, RC element

Ordering data					
PUSH IN connection Type	TRP 60VUC 2CO AU	TRP 120VUC 2CO AU	TRP 230VUC 2CO AU	TRP 120VAC RC 2CO AU	TRP 230VAC RC 2CO AU
Order No.	2618360000	2618590000	2618300000	2618490000	2618500000
Screw connection Type	TRS 60VUC 2CO AU	TRS 120VUC 2CO AU	TRS 230VUC 2CO AU	TRS 120VAC RC 2CO AU	TRS 230VAC RC 2CO AU
Order No.	1123770000	1123780000	1123790000	1123800000	1123810000
Note					

**Solid-state relay, 3...48 V DC / 100 mA**

**Output versions**

- Space saving, just 6.4 mm modular width
- 100 mA DC Output current
- PUSH IN and screw connection

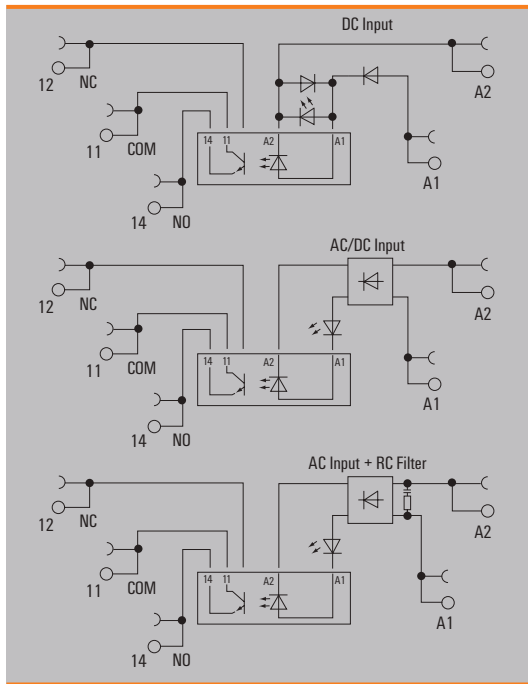

**Technical data**

Load side			
Rated switching voltage	3... 48 V DC		
Continuous current	0.1 A		
Inrush current			
Contact type	1 NO contact (Bipolar transistor)		
Voltage drop at max. load	≤ 1 V		
Leakage current	<10 µA		
Short-circuit-proof / Protective circuit, load side	No / Free-wheeling diode		
General data			
Ambient temperature (operational)	-20 °C...60 °C		
Storage temperature	-40 °C...70 °C		
Humidity	5-95% relative humidity, T <sub>0</sub> = 40°C, without condensation		
Approvals	CE; cULus; DETNORVER; UKCA		
Insulation coordinates			
Rated voltage	300 V		
Impulse withstand voltage	6 kV (1.2/50 µs)		
Dielectric strength for control side - load side	2.5 kV <sub>eff</sub>		
Dielectric strength to mounting rail	4 kV <sub>eff</sub> / 1 Min.		
Clearance and creepage distances for control side - load side	≥ 5.5 mm		
Overvoltage category	III		
Pollution degree	2		
Dimensions			
Clamping range (nominal / min. / max.)	<b>PUSH IN connection</b>	<b>Screw connection</b>	
	mm <sup>2</sup>	1.5 / 0.14 / 2.5	1.5 / 0.14 / 2.5
Depth x width x height	mm	87.8 / 6.4 / 89.4	87.8 / 6.4 / 89.6
<b>Note</b>	Accessories and dimensional drawings: refer to the TERMSERIES Accessories page. Further approvals and technical data can be found at <a href="http://eshop.weidmueller.com">eshop.weidmueller.com</a>		

Solid-state relay, 3...48 V DC / 100 mA

Output versions

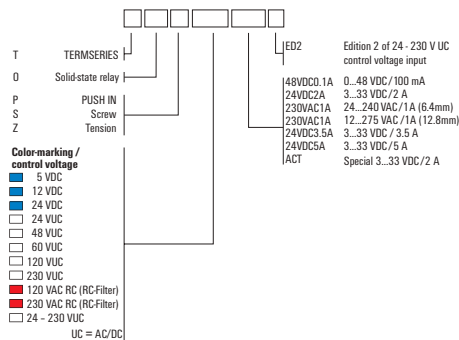

Ordering data

Control side

	5 V DC	12 V DC	24 V DC	24 V UC	48 V UC
Rated control voltage	5 V DC $\pm 20\%$	12 V DC $\pm 20\%$	24 V DC $\pm 20\%$	24 V UC $\pm 10\%$	48 V UC $\pm 10\%$
Nominal control current	7 mA DC ( $\pm 20\%$ )	5 mA DC ( $\pm 20\%$ )	10 mA DC $\pm 20\%$	10 mA AC $\pm 20\%$ , 6 mA DC ( $\pm 20\%$ )	8 mA AC ( $\pm 20\%$ ), 7 mA DC ( $\pm 20\%$ )
Power rating	35 mW	112 mW	280 mW	154 mW	290 mVA / 192 mW
max. switching frequency (DC control voltage)	10 Hz	10 Hz	300 Hz	100 Hz	100 Hz
max. switching frequency (AC control voltage)				3 Hz	3 Hz
Status indicator	Green LED	Green LED	Green LED	Green LED	Green LED
Protective circuit	Free-wheeling diode, Reverse polarity protection	Rectifier	Free-wheeling diode, Reverse polarity protection	Rectifier	Rectifier

Ordering data

PUSH IN connection	Type	TOP 5VDC 48VDC0.1A	TOP 12VDC 48VDC0.1A	TOP 24VDC 48VDC0.1A	TOP 24VUC 48VDC0.1A	TOP 48VUC 48VDC0.1A
	Order No.	<b>2614860000</b>	<b>2618600000</b>	<b>2618790000</b>	<b>2618640000</b>	<b>2618710000</b>
Screw connection	Type	TOS 5VDC 48VDC0.1A	TOS 12VDC 48VDC0.1A	TOS 24VDC 48VDC0.1A	TOS 24VUC 48VDC0.1A	TOS 48VUC 48VDC0.1A
	Order No.	<b>1126920000</b>	<b>1126930000</b>	<b>1126940000</b>	<b>1126950000</b>	<b>1126960000</b>

<b>Note</b>						
-------------	--	--	--	--	--	--

Ordering data

Control side

	60 V UC	120 V UC	230 V UC	120 V AC RC	230 V AC RC
Rated control voltage	60 V UC $\pm 10\%$	120 V UC $\pm 10\%$	230 V UC $\pm 10\%$	120 V AC $\pm 10\%$	230 V AC $\pm 10\%$
Nominal control current	4.8 mA AC ( $\pm 10\%$ ), 2.5 mA DC ( $\pm 10\%$ )	5 mA AC ( $\pm 30\%$ ), 3 mA DC ( $\pm 30\%$ )	3.5 mA AC ( $\pm 5\%$ ), 2.9 mA DC ( $\pm 5\%$ )	7 mA AC ( $\pm 20\%$ )	9 mA AC
Power rating	150 mW, 290 mVA	0.48 VA	670 mW, 805 mVA	0.84 VA	1.9 VA
max. switching frequency (DC control voltage)	10 Hz	3 Hz	3 Hz		
max. switching frequency (AC control voltage)	3 Hz	3 Hz	3 Hz	3 Hz	3 Hz
Status indicator	Green LED	Green LED	Green LED	Green LED	Green LED
Protective circuit	Rectifier	Rectifier	Rectifier	Rectifier, RC element	Rectifier, RC element

Ordering data

PUSH IN connection	Type	TOP 60VUC 48VDC0.1A	TOP 120VUC 48VDC0.1A	TOP 230VUC 48VDC0.1A	TOP 120VAC RC 48VDC0.1A	TOP 230VAC RC 48VDC0.1A
	Order No.	<b>2614880000</b>	<b>2618680000</b>	<b>2618690000</b>	<b>2618650000</b>	<b>2618620000</b>
Screw connection	Type	TOS 60VUC 48VDC0.1A	TOS 120VUC 48VDC0.1A	TOS 230VUC 48VDC0.1A	TOS 120VAC RC 48VDC0.1A	TOS 230VAC RC 48VDC0.1A
	Order No.	<b>1126970000</b>	<b>1126980000</b>	<b>1126990000</b>	<b>1127000000</b>	<b>1127010000</b>

<b>Note</b>						
-------------	--	--	--	--	--	--

**Solid-state relay, 3...48 V DC / 100 mA**

**Output versions, multi-voltage input**

- Space saving, just 6.4 mm modular width
- 100 mA DC Output current
- PUSH IN and screw connection
- Multi-voltage input: 24...230 V UC in one module

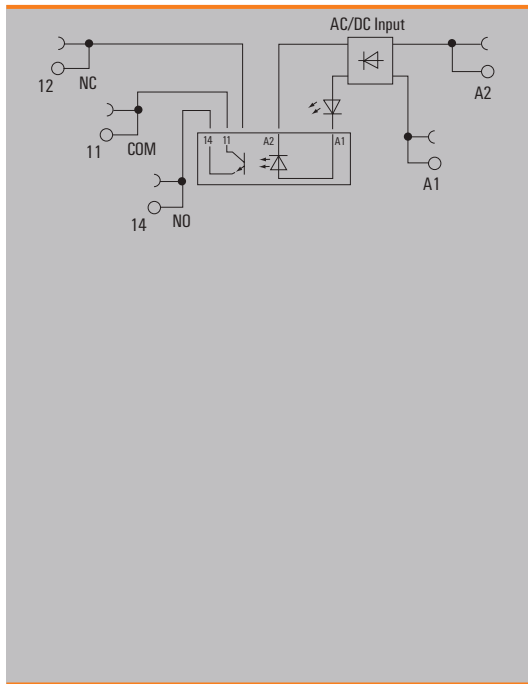

**Technical data**

Load side		
Rated switching voltage	3... 48 V DC	
Continuous current	0.1 A	
Inrush current		
Contact type	1 NO contact (Bipolar transistor)	
Voltage drop at max. load	≤ 1 V	
Leakage current	<10 µA	
Short-circuit-proof / Protective circuit, load side	No / Free-wheeling diode	
General data		
Ambient temperature (operational)	-20 °C...60 °C	
Storage temperature	-40 °C...70 °C	
Humidity	5-95% relative humidity, T <sub>0</sub> = 40°C, without condensation	
Insulation coordinates		
Rated voltage	300 V	
Impulse withstand voltage	6 kV (1.2/50 µs)	
Dielectric strength for control side - load side	3.51 kV <sub>eff</sub> / 1 min.	
Dielectric strength to mounting rail	3.51 kV <sub>eff</sub> / 1 min.	
Clearance and creepage distances for control side - load side	≥ 6 mm	
Overvoltage category	III	
Pollution degree	2	
Dimensions		
	<b>PUSH IN connection</b>	<b>Screw connection</b>
Clamping range (nominal / min. / max.)	mm <sup>2</sup> 1.5 / 0.14 / 2.5	1.5 / 0.14 / 2.5
Depth x width x height	mm 87.8 / 6.4 / 89.4	87.8 / 6.4 / 89.6
<b>Note</b>	Accessories and dimensional drawings: refer to the TERMSERIES Accessories page. Further approvals and technical data can be found at <a href="http://eshop.weidmueller.com">eshop.weidmueller.com</a>	

**Ordering data**

Control side	
Rated control voltage	24...230 V UC ±10 %
Nominal control current	11.0 mA at 24 V DC, 1.1 mA at 230 V DC, 19.0 mA at 24 V AC, 2.8 mA at 230 V AC
Power rating	265 mW @ 24 V DC, 255 mW @ 230 V DC, 455 mVA @ 24 V AC, 645 mVA @ 230 V AC
max. switching frequency (DC control voltage)	3 Hz
max. switching frequency (AC control voltage)	3 Hz
Status indicator	Green LED
Protective circuit	Rectifier
Approvals	CE; cULus; DETNORVER; UKCA

Ordering data	
PUSH IN connection	Type TOP 24-230VUC 48VDC0,1A ED2
Order No.	<b>2663070000</b>
Screw connection	Type TOS 24-230VUC 48VDC0,1A ED2
Order No.	<b>2662910000</b>
Note	



## High switching frequencies

### Special solid-state relays for reliable and fast decoupling of signals up to 550 kHz

#### C

Due to their design, solid-state relays can already switch significantly faster than electromechanical relays. However, there are applications in which signals have to be switched even faster or at an even higher frequency. For particularly fast switching processes, or the transmission of signals with high switching frequencies between 1 and 550 kHz, we have developed special solid-state relays that are precisely tailored to these specific applications.

Our solid-state relays for high switching frequencies guarantee the reliable and fast decoupling of signals. They can be used to implement extremely fast switching processes or to transmit signals with switching frequencies of up to 550 kHz.

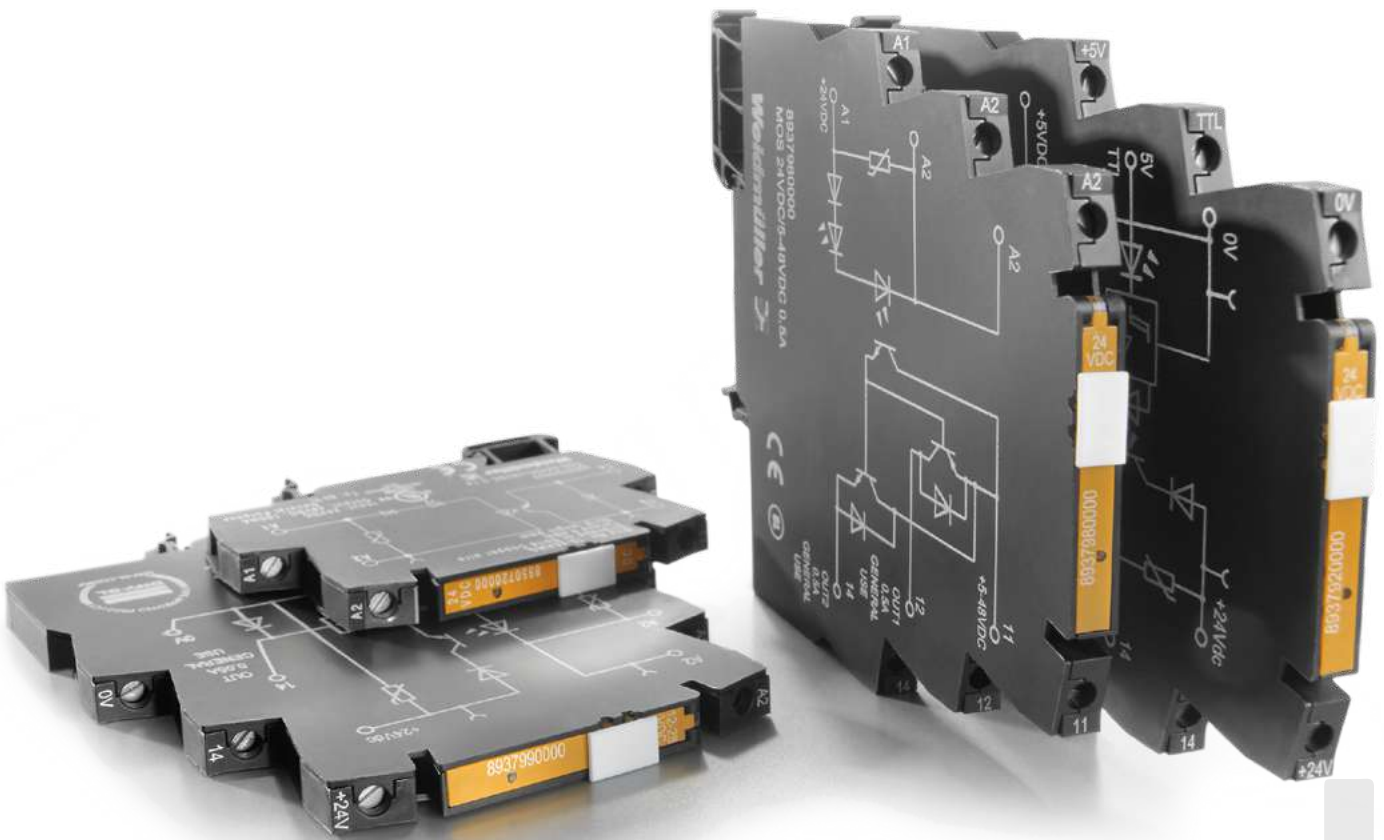

Visit our website for more information  
[www.weidmueller.com/hf](http://www.weidmueller.com/hf)

## High switching frequencies – MICROOPTO

### For high switching frequency up to 100 kHz

- Width only 6 mm
- Plug-in cross-connector
- For mounting on TS 35

### 12...28 V DC 100 kHz

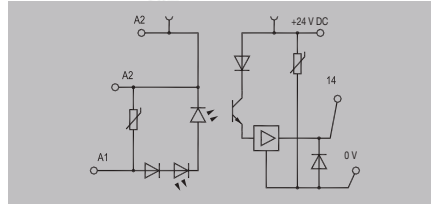

#### Technical data

Control side	
Rated control voltage	12 V DC...28 V DC
Power rating	≤ 360 mW
Pull-in/drop-out voltage, typ.	5.6 V / 5 V DC
Input frequency	100 kHz
Status indicator	Green LED
Protective circuit	Varistor, Reverse polarity protection
Load side	
Solid-state type	Transistor
Rated switching voltage	19.6...28.8 V DC
Continuous current	50 mA
Voltage drop at max. load	≤ 2 V
Leakage current	<1 μA
Short-circuit-proof / Protective circuit, load side	No / Varistor, Reverse polarity protection
Switch-on delay / Switch-off delay	<200 ns / <400 ns
Pulse load, max. current	0.6 A (20 ms)
Load category	LC A
General data	
Ambient temperature (operational)	-25 °C...60 °C
Storage temperature	-40 °C...80 °C
UL 94 flammability rating	V-0
Humidity	5-95% relative humidity, T <sub>v</sub> = 55 °C, without condensation
Approvals	CE; cULus; DETNORVER; UKCA
Insulation coordinates	
Rated voltage	30 V
Impulse withstand voltage	500 V (1,2/50 μ)
Dielectric strength for control side - load side	350 V <sub>eff</sub> / 1 min.
Dielectric strength to mounting rail	350 V <sub>eff</sub> / 1 min.
Clearance and creepage distances for control side - load side	
Overtension category	II
Pollution degree	2
Dimensions	
Clamping range (nominal / min. / max.)	mm <sup>2</sup>
Depth x width x height	mm
Note	

Screw connection		
Type	Qty.	Order No.
MOS 12-28VDC 100KHZ	1	8937990000

#### Ordering data

Screw connection	
Note	

#### Accessories

Note	
Accessories and dimensioned drawings: refer to the MICROOPTO Accessories page.	

A special interior circuit in the opto module **MICROOPTO 100 kHz** ensures that rapidly transmitted signals are isolated from one another and that they can be transferred practically without delay. This allows switching frequencies up to 100 kHz to be achieved. Comprehensive suppressor circuits safeguard the module against conducted transients and voltage spikes.

#### Max. switching frequency is dependent on the duty cycle deviation

MOS 12-28 V DC 100 kHz (switching current 50 mA, ohmic load)

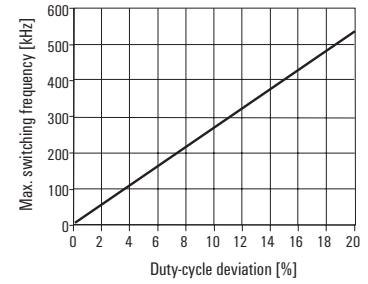

#### For example rotational speed measurement

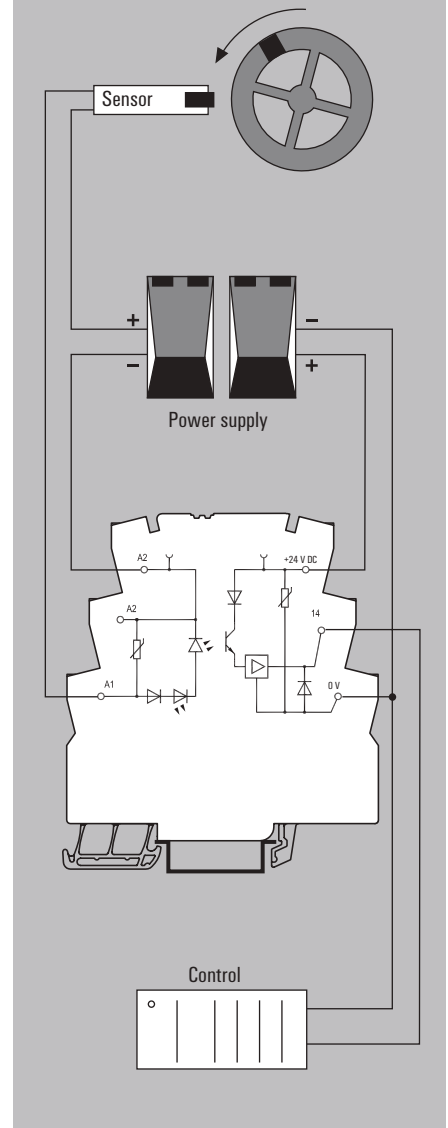

For adjusting TTL signals

5 V TTL / 24 V DC 0.1 A

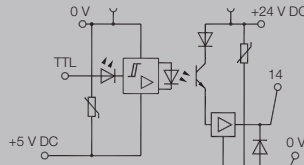

To adjust sensitive TTL signals to the typical voltage level of 24 V DC used in industrial automation applications, the MICROOPTO TTL modules are used.

For the protection of the electronics, the sensitive TTL signals require electrical isolation from the 24 V world.

To control the optical coupler circuit via the 5 V TTL signal, an additional auxiliary voltage is fed in.

Technical data

Control side	
Rated control voltage	5 V TTL
Power rating	<0.5 mW
Pull-in/drop-out voltage, typ.	2 V / 1 V DC
Input frequency	100 kHz
Status indicator	Green LED
Protective circuit	Varistor, Reverse polarity protection
Load side	
Solid-state type	Bipolar transistor
Rated switching voltage	24 VDC ±20%
Continuous current	100 mA
Voltage drop at max. load	<1 V
Leakage current	<20 µA
Short-circuit-proof / Protective circuit, load side	No / Free-wheeling diode
Switch-on delay / Switch-off delay	<1.3 µs / <1 µs
Pulse load, max. current	
Load category	LC A
General data	
Ambient temperature (operational)	-25 °C...60 °C
Storage temperature	-40 °C...60 °C
UL 94 flammability rating	V-0
Humidity	5 - 93% rel. humidity, Tu = 40°C, no condensation
Approvals	CE; cULus; DETNORVER; UKCA
Insulation coordinates	
Rated voltage	300 V
Impulse withstand voltage	4 kV (1.2/50 µs)
Dielectric strength for control side - load side	3 kV <sub>eff</sub> / 1 Min.
Dielectric strength to mounting rail	4 kV <sub>eff</sub> / 1 Min.
Clearance and creepage distances for control side - load side	> 3 mm
Overvoltage category	III
Pollution degree	2
Dimensions	
Clamping range (nominal / min. / max.)	mm <sup>2</sup>
Depth x width x height	mm
Note	

Screw connection		
Type	Qty.	Order No.
MOS 5VTTL/24VDC 0,1A	1	8937920000

Ordering data

Screw connection
------------------

Note

Accessories

Note
------

Accessories and dimensioned drawings: refer to the MICROOPTO Accessories page.		
--	--	--

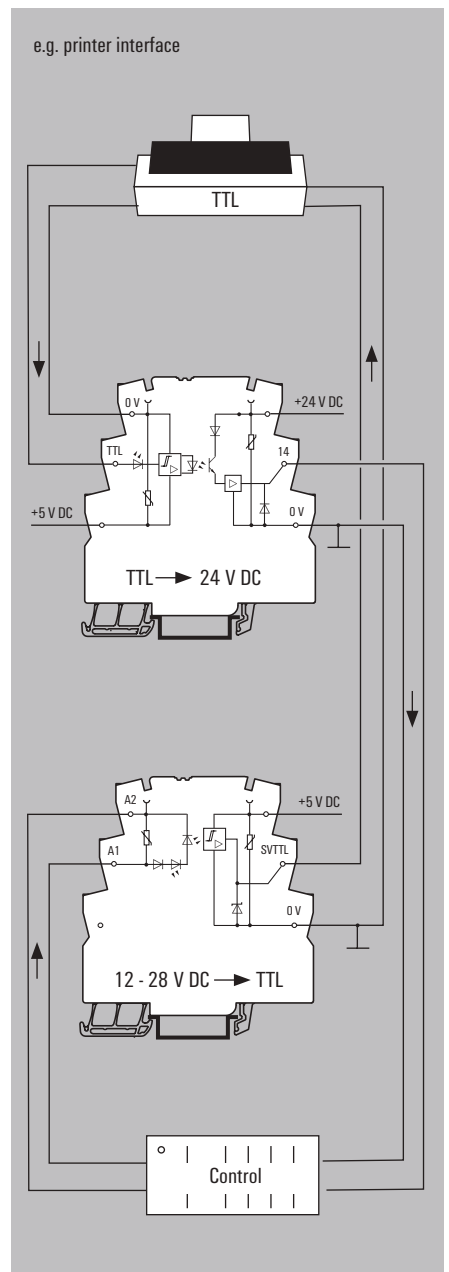

For adjusting TTL signals

12-28 V DC / 5 V TTL

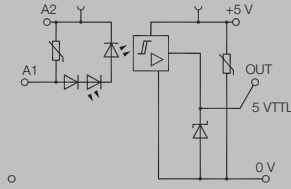

To adjust sensitive TTL signals to the typical voltage level of 24 V DC used in industrial automation applications, the **MICROOPTO TTL** modules are used.

For the protection of the electronics, the sensitive TTL signals require electrical isolation from the 24 V world.

To control the optical coupler circuit via the 5 V TTL signal, an additional auxiliary voltage is fed in.

Technical data

Control side

Rated control voltage  
Power rating  
Pull-in/drop-out voltage, typ.

Input frequency  
Status indicator  
Protective circuit

Load side

Solid-state type  
Rated switching voltage  
Continuous current  
Voltage drop at max. load  
Leakage current  
Short-circuit-proof / Protective circuit, load side

Switch-on delay / Switch-off delay  
Pulse load, max. current  
Load category

General data

Ambient temperature (operational)  
Storage temperature  
UL 94 flammability rating  
Humidity  
Approvals

Insulation coordinates

Rated voltage  
Impulse withstand voltage  
Dielectric strength for control side - load side  
Dielectric strength to mounting rail  
Clearance and creepage distances for control side - load side  
Overvoltage category  
Pollution degree

Dimensions

Clamping range (nominal / min. / max.) mm<sup>2</sup>  
Depth x width x height mm

Note

Ordering data

Screw connection

Note

Accessories

Note

12 V DC...28 V DC  
150 mW  
10.7 V / 10.6 V DC

100 kHz  
Green LED  
Varistor, Reverse polarity protection

TTL  
5 V TTL  
50 mA  
≤ 1.1 V  
<1 μA  
No / Varistor

typ. <1 μs / typical. <4 μs

LC A

-25 °C...60 °C  
-40 °C...60 °C  
V-0  
5 - 93% rel. humidity, Tu = 40 °C, no condensation  
CE; cULus; DETNORVER; UKCA

300 V  
4 kV (1.2/50 μs)  
3 kV<sub>eff</sub> / 1 Min.  
4 kV<sub>eff</sub> / 1 Min.  
> 3 mm  
III  
2

Screw connection

2.5 / 0.5 / 4  
97.8 / 6.1 / 88.1

Type	Qty.	Order No.
MOS 12-28VDC/5VTTL	1	8937930000

Accessories and dimensioned drawings: refer to the MICROOPTO Accessories page.

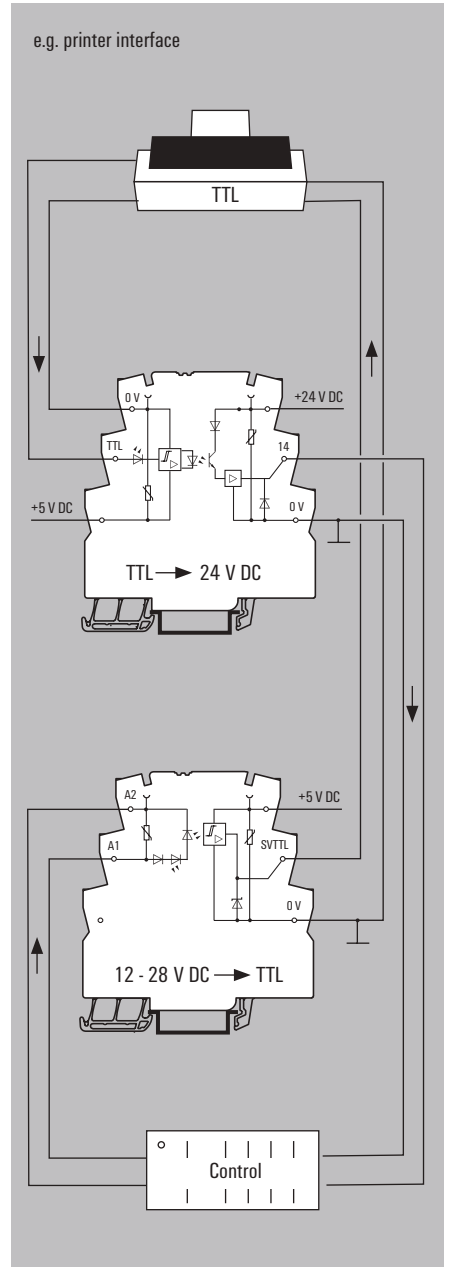



**Solid-state relays 5...48 V DC / 100 mA**

**Output versions**

- Space-saving 6.1 mm width
- Plug-in cross-connections
- Screw and PUSH IN wire connection
- Enclosed design

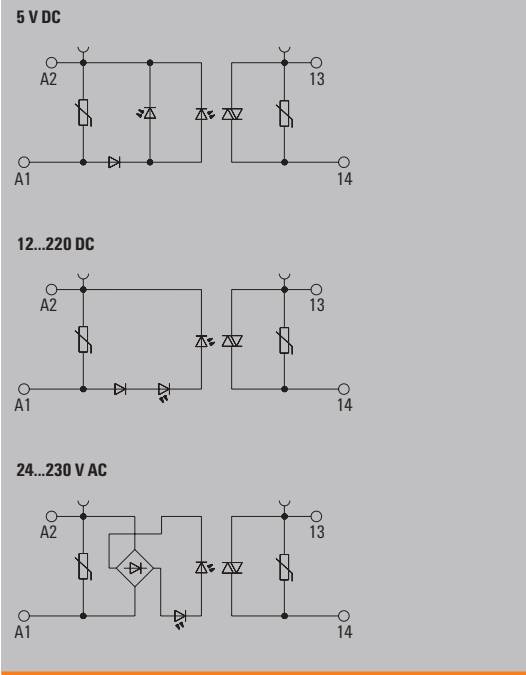

**Technical data**

Load side		
Rated switching voltage	24...230 V AC	
Continuous current	100 mA	
Inrush current		
Solid-state type	Triac (zero-cross switch)	
Voltage drop at max. load	<1.8 V	
Leakage current	<1 mA	
Protective circuit, load side	Varistor, RC element	
Short-circuit-proof / Protective circuit, load side	No / Varistor, RC element	
General data		
Ambient temperature (operational)	-20 °C...60 °C	
Storage temperature	-40 °C...80 °C	
Humidity	5-95% relative humidity, T <sub>0</sub> = 40°C, without condensation	
Approvals	CE, cULus	
Insulation coordinates		
Rated voltage	300 V	
Impulse withstand voltage	4 kV (1.2/50 µs)	
Dielectric strength for control side - load side	1.2 kV <sub>eff</sub> / 1 min.	
Dielectric strength to mounting rail		
Clearance and creepage distances for control side - load side	> 3 mm	
Overvoltage category	III	
Pollution degree	2	
Dimensions		
Clamping range (nominal / min. / max.)	Screw connection	2.5 / 0.5 / 4
	PUSH IN connection	1.5 / 0.5 / 2.5
Depth x width x height	Screw connection	55 / 6.1 / 74.4
	PUSH IN connection	55 / 6.1 / 79.4
<b>Note</b>	Accessories and dimensioned drawings: refer to the TERMOPTO Accessories page.	

**Applications**

The **TERMOPTO** opto module is used in industrial applications in which electrical isolation and signal conditioning without switching amplification is sufficient.

The compact design in terminal-block format saves space on the rail and offers the option of a pluggable cross connection.

The choice between 10 input voltages and 3 output voltages as well as between screw or PUSH IN connection technology gives 60 variations for different applications.

The integrated protective circuit ensures sufficient protection in applications with resistive as well as slightly inductive and capacitive loads. For purely inductive, capacitive or comparable loads with high switch-on and switch-off peaks, such as solenoid valves or filament lamps, ensure that the module is dimensioned appropriately or an additional safeguard is used.

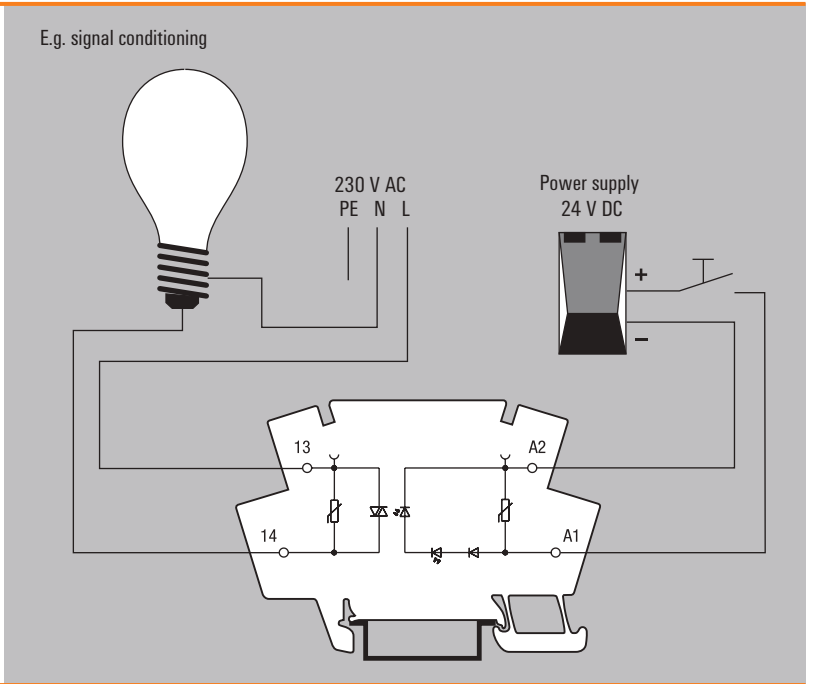

Solid-state relays 5...48 V DC / 100 mA

Output versions

Ordering data

	5 V DC	12 V DC	24 V DC
<b>Control side</b>			
Rated control voltage	5 V DC $\pm 20\%$	12 V DC $\pm 20\%$	24 V DC $\pm 20\%$
Nominal control current	7.8 mA DC	3.6 mA DC	3.6 mA DC
Power rating	<40 mW	<45 mW	$\leq 80$ mW
max. switching frequency (DC control voltage)	10 Hz	10 Hz	10 Hz
max. switching frequency (AC control voltage)			
Status indicator	Green LED	Green LED	Green LED
Protective circuit	Varistor, Reverse polarity protection	Varistor, Reverse polarity protection	Varistor, Reverse polarity protection

Ordering data				
Screw connection	Type	TOS 5VDC/230VAC 0,1A	TOS 12VDC/230VAC 0,1A	TOS 24VDC/230VAC 0,1A
	Order No.	<b>8951100000</b>	<b>8951110000</b>	<b>8951120000</b>
PUSH IN connection	Type	TOP 5VDC/230VAC 0,1A	TOP 12VDC/230VAC 0,1A	TOP 24VDC/230VAC 0,1A
	Order No.	<b>8951160000</b>	<b>8951170000</b>	<b>8951180000</b>
<b>Note</b>				

## Signal adaption

### Custom-fit relays for signal adaption and transmission

#### C

To adapt signals and transmit them from other systems at the panel level, relays and solid-state relays are required that are precisely tailored to the application. We offer you a range of high-quality and particularly space-saving relay products for these special applications.

In our portfolio you will find, for example, special variants for transmitting 5 V TTL signals to the inputs and outputs of PLC systems or industrial computers. What's more, we offer variants which, in contrast to conventional 1 NO contact solid-state relays, have a 1 CO contact output. These products are particularly suitable for inverting signals.

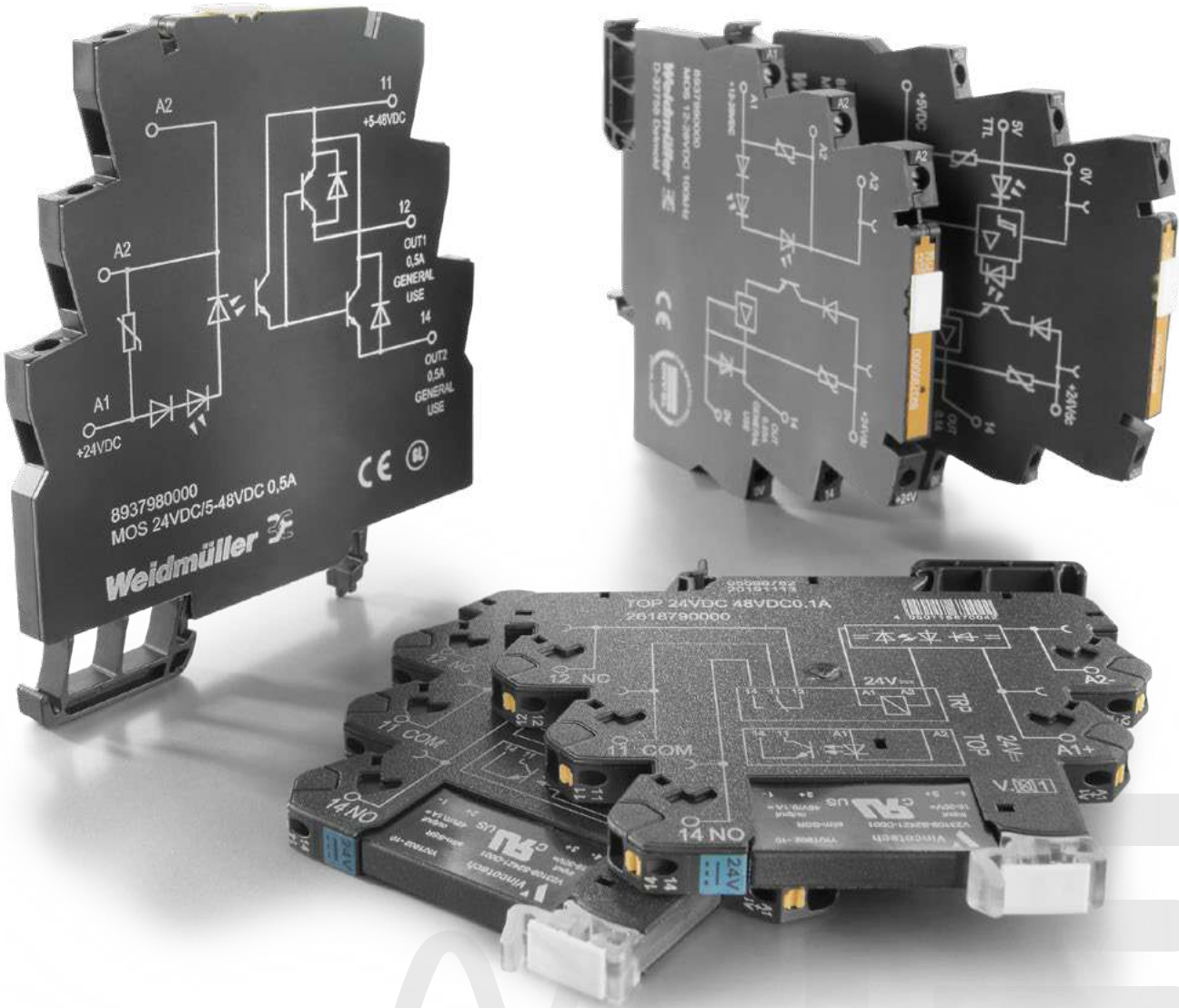

Visit our website for more information  
[www.weidmueller.com/sa](http://www.weidmueller.com/sa)

For electronically switching or inverting signals

24 V DC / 5-48 V DC 0.5 A



Electronic CO contacts are used anywhere output signals need to be changed over.

For this purpose, the input signal is directly switched through to the output side and inverted; as a result, the opto module can also be used as a pure inverter.

The advantage over electromechanical relays lies in the wear-free switching and the possibility of realising high switching frequencies.

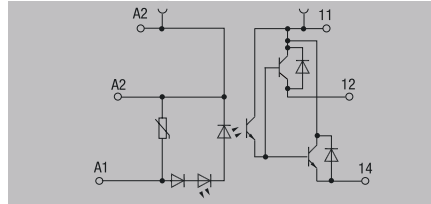

Technical data

Control side	
Rated control voltage	24 V DC ±20 %
Power rating	160 mW
Pull-in/drop-out voltage, typ.	19.5 V / 12 V DC
Input frequency	1 kHz
Status indicator	Green LED
Protective circuit	Varistor, Reverse polarity protection
Load side	
Solid-state type	Transistor
Rated switching voltage	5...48 V DC
Continuous current	500 mA
Voltage drop at max. load	Max. 1 V
Leakage current	<1.5 mA
Short-circuit-proof / Protective circuit, load side	No / Free-wheeling diode
Switch-on delay / Switch-off delay	<30 µs / <50 µs
Pulse load, max. current	LC A
Load category	LC A
General data	
Ambient temperature (operational)	-25 °C...60 °C
Storage temperature	-40 °C...60 °C
UL 94 flammability rating	V-0
Humidity	5 - 93% rel. humidity, Tu = 40°C, no condensation
Approvals	CE; cULus; DETNORVER; UKCA
Insulation coordinates	
Rated voltage	300 V
Impulse withstand voltage	4 kV (1.2/50 µs)
Dielectric strength for control side - load side	3 kV <sub>eff</sub> / 1 Min.
Dielectric strength to mounting rail	4 kV <sub>eff</sub> / 1 Min.
Clearance and creepage distances for control side - load side	> 3 mm
Overvoltage category	III
Pollution degree	2
Dimensions	
Clamping range (nominal / min. / max.)	mm <sup>2</sup>
Depth x width x height	mm
Note	

Screw connection		
Type	Qty.	Order No.
MOS 24VDC/5-48VDC 0,5A	1	8937980000

Ordering data

Screw connection	
Note	

Accessories

Note	
Accessories and dimensioned drawings: refer to the MICROOPTO Accessories page.	

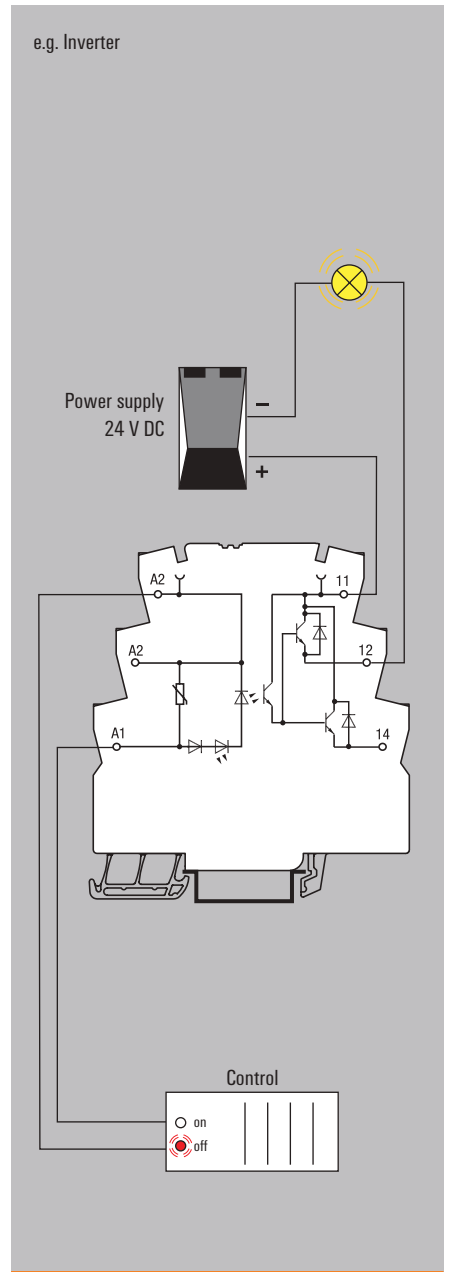

## For adjusting TTL signals

## 5 V TTL / 24 V DC 0.1 A

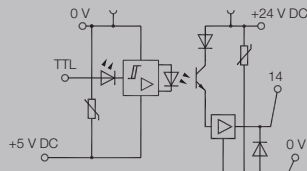

## Technical data

## Control side

Rated control voltage  
Power rating  
Pull-in/drop-out voltage, typ.

Input frequency  
Status indicator  
Protective circuit

## Load side

Solid-state type  
Rated switching voltage  
Continuous current  
Voltage drop at max. load  
Leakage current  
Short-circuit-proof / Protective circuit, load side

Switch-on delay / Switch-off delay  
Pulse load, max. current  
Load category

## General data

Ambient temperature (operational)  
Storage temperature  
UL 94 flammability rating  
Humidity  
Approvals

## Insulation coordinates

Rated voltage  
Impulse withstand voltage  
Dielectric strength for control side - load side  
Dielectric strength to mounting rail  
Clearance and creepage distances for control side - load side  
Overvoltage category  
Pollution degree

## Dimensions

Clamping range (nominal / min. / max.) mm<sup>2</sup>  
Depth x width x height mm

## Note

## Ordering data

Screw connection

## Note

## Accessories

## Note

5 V TTL  
<0.5 mW  
2 V / 1 V DC

100 kHz  
Green LED  
Varistor, Reverse polarity protection

Bipolar transistor  
24 VDC ±20%  
100 mA  
<1 V  
<20 µA  
No / Free-wheeling diode

&lt;1.3 µ / &lt;1 µs

## LC A

-25 °C...60 °C  
-40 °C...60 °C  
V-0  
5 - 93% rel. humidity, Tu = 40°C, no condensation  
CE; cULus; DETNORVER; UKCA

300 V  
4 kV (1.2/50 µs)  
3 kV<sub>eff</sub> / 1 Min.  
4 kV<sub>eff</sub> / 1 Min.  
> 3 mm  
III  
2

## Screw connection

2.5 / 0.5 / 4  
97.8 / 6.1 / 88.1

Type	Qty.	Order No.
MOS 5VTTL/24VDC 0,1A	1	8937920000

Accessories and dimensioned drawings: refer to the MICROOPTO Accessories page.

To adjust sensitive TTL signals to the typical voltage level of 24 V DC used in industrial automation applications, the MICROOPTO TTL modules are used.

For the protection of the electronics, the sensitive TTL signals require electrical isolation from the 24 V world.

To control the optical coupler circuit via the 5 V TTL signal, an additional auxiliary voltage is fed in.

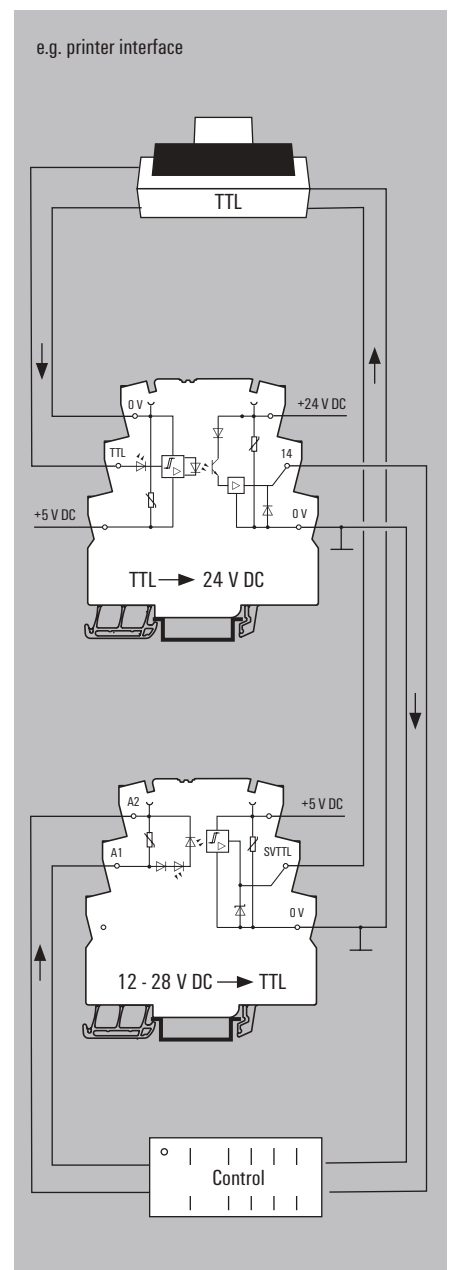

## Signal adaption - MICROOPTO

### For adjusting TTL signals

### 12-28 V DC / 5 V TTL

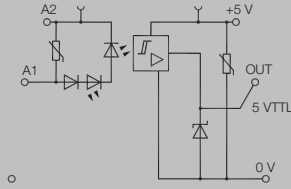

To adjust sensitive TTL signals to the typical voltage level of 24 V DC used in industrial automation applications, the **MICROOPTO TTL** modules are used.

For the protection of the electronics, the sensitive TTL signals require electrical isolation from the 24 V world.

To control the optical coupler circuit via the 5 V TTL signal, an additional auxiliary voltage is fed in.

#### Technical data

##### Control side

Rated control voltage  
Power rating  
Pull-in/drop-out voltage, typ.

Input frequency  
Status indicator  
Protective circuit

##### Load side

Solid-state type  
Rated switching voltage  
Continuous current  
Voltage drop at max. load  
Leakage current  
Short-circuit-proof / Protective circuit, load side

Switch-on delay / Switch-off delay  
Pulse load, max. current  
Load category

##### General data

Ambient temperature (operational)  
Storage temperature  
UL 94 flammability rating  
Humidity  
Approvals

##### Insulation coordinates

Rated voltage  
Impulse withstand voltage  
Dielectric strength for control side - load side  
Dielectric strength to mounting rail  
Clearance and creepage distances for control side - load side  
Overvoltage category  
Pollution degree

##### Dimensions

Clamping range (nominal / min. / max.) mm<sup>2</sup>  
Depth x width x height mm

##### Note

#### Ordering data

Screw connection

##### Note

#### Accessories

##### Note

12 V DC...28 V DC  
150 mW  
10.7 V / 10.6 V DC

100 kHz  
Green LED  
Varistor, Reverse polarity protection

TTL  
5 V TTL  
50 mA  
≤ 1.1 V  
<1 μA  
No / Varistor

typ. <1 μs / typical. <4 μs

##### LC A

-25 °C...60 °C  
-40 °C...60 °C  
V-0  
5 - 93% rel. humidity, Tu = 40 °C, no condensation  
CE; cULus; DETNORVER; UKCA

300 V  
4 kV (1.2/50 μs)  
3 kV<sub>eff</sub> / 1 Min.  
4 kV<sub>eff</sub> / 1 Min.  
> 3 mm  
III  
2

##### Screw connection

2.5 / 0.5 / 4  
97.8 / 6.1 / 88.1

Type	Qty.	Order No.
MOS 12-28VDC/5VTTL	1	8937930000

Accessories and dimensioned drawings: refer to the MICROOPTO Accessories page.

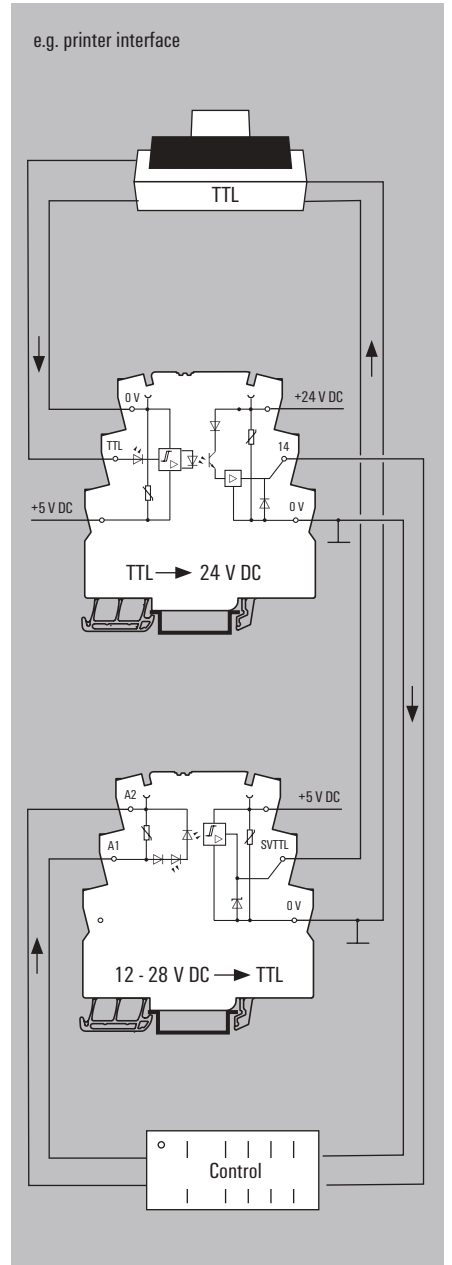



Solid-state relay, 3...48 V DC / 100 mA

Output versions

- Space saving, just 6.4 mm modular width
- 100 mA DC Output current
- PUSH IN and screw connection

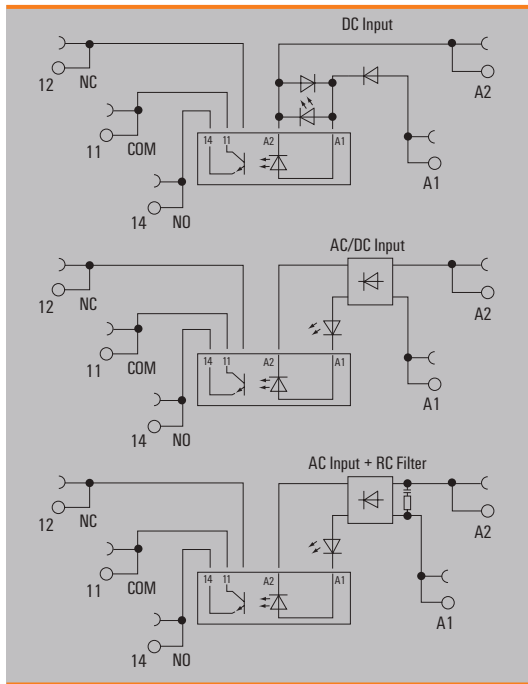

Technical data

Load side		
Rated switching voltage	3... 48 V DC	
Continuous current	0.1 A	
Inrush current		
Contact type	1 NO contact (Bipolar transistor)	
Voltage drop at max. load	≤ 1 V	
Leakage current	<10 µA	
Short-circuit-proof / Protective circuit, load side	No / Free-wheeling diode	
General data		
Ambient temperature (operational)	-20 °C...60 °C	
Storage temperature	-40 °C...70 °C	
Humidity	5-95% relative humidity, T <sub>90</sub> = 40°C, without condensation	
Approvals	CE; cULus; DETNORVER; UKCA	
Insulation coordinates		
Rated voltage	300 V	
Impulse withstand voltage	6 kV (1.2/50 µs)	
Dielectric strength for control side - load side	2.5 kV <sub>eff</sub>	
Dielectric strength to mounting rail	4 kV <sub>eff</sub> / 1 Min.	
Clearance and creepage distances for control side - load side	≥ 5.5 mm	
Overvoltage category	III	
Pollution degree	2	
Dimensions		
	<b>PUSH IN connection</b>	<b>Screw connection</b>
Clamping range (nominal / min. / max.)	mm <sup>2</sup> 1.5 / 0.14 / 2.5	1.5 / 0.14 / 2.5
Depth x width x height	mm 87.8 / 6.4 / 89.4	87.8 / 6.4 / 89.6
<b>Note</b>	Accessories and dimensional drawings: refer to the TERMSERIES Accessories page. Further approvals and technical data can be found at <a href="http://eshop.weidmueller.com">eshop.weidmueller.com</a>	

Solid-state relay, 3...48 V DC / 100 mA

Output versions

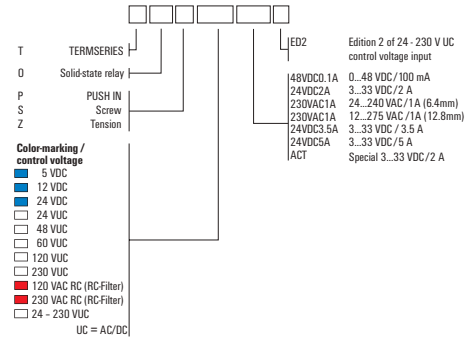

Ordering data

Control side	5 V DC	12 V DC	24 V DC	24 V UC	48 V UC
Rated control voltage	5 V DC $\pm 20\%$	12 V DC $\pm 20\%$	24 V DC $\pm 20\%$	24 V UC $\pm 10\%$	48 V UC $\pm 10\%$
Nominal control current	7 mA DC ( $\pm 20\%$ )	5 mA DC ( $\pm 20\%$ )	10 mA DC $\pm 20\%$	10 mA AC $\pm 20\%$ , 6 mA DC ( $\pm 20\%$ )	8 mA AC ( $\pm 20\%$ ), 7 mA DC ( $\pm 20\%$ )
Power rating	35 mW	112 mW	280 mW	154 mW	290 mVA / 192 mW
max. switching frequency (DC control voltage)	10 Hz	10 Hz	300 Hz	100 Hz	100 Hz
max. switching frequency (AC control voltage)				3 Hz	3 Hz
Status indicator	Green LED	Green LED	Green LED	Green LED	Green LED
Protective circuit	Free-wheeling diode, Reverse polarity protection	Rectifier	Free-wheeling diode, Reverse polarity protection	Rectifier	Rectifier

Ordering data					
PUSH IN connection Type	TOP 5VDC 48VDC0.1A	TOP 12VDC 48VDC0.1A	TOP 24VDC 48VDC0.1A	TOP 24VUC 48VDC0.1A	TOP 48VUC 48VDC0.1A
Order No.	<b>2614860000</b>	<b>2618600000</b>	<b>2618790000</b>	<b>2618640000</b>	<b>2618710000</b>
Screw connection Type	TOS 5VDC 48VDC0.1A	TOS 12VDC 48VDC0.1A	TOS 24VDC 48VDC0.1A	TOS 24VUC 48VDC0.1A	TOS 48VUC 48VDC0.1A
Order No.	<b>1126920000</b>	<b>1126930000</b>	<b>1126940000</b>	<b>1126950000</b>	<b>1126960000</b>
Note					

Ordering data

Control side	60 V UC	120 V UC	230 V UC	120 V AC RC	230 V AC RC
Rated control voltage	60 V UC $\pm 10\%$	120 V UC $\pm 10\%$	230 V UC $\pm 10\%$	120 V AC $\pm 10\%$	230 V AC $\pm 10\%$
Nominal control current	4.8 mA AC ( $\pm 10\%$ ), 2.5 mA DC ( $\pm 10\%$ )	5 mA AC ( $\pm 30\%$ ), 3 mA DC ( $\pm 30\%$ )	3.5 mA AC ( $\pm 5\%$ ), 2.9 mA DC ( $\pm 5\%$ )	7 mA AC ( $\pm 20\%$ )	9 mA AC
Power rating	150 mW, 290 mVA	0.48 VA	670 mW, 805 mVA	0.84 VA	1.9 VA
max. switching frequency (DC control voltage)	10 Hz	3 Hz	3 Hz		
max. switching frequency (AC control voltage)	3 Hz	3 Hz	3 Hz	3 Hz	3 Hz
Status indicator	Green LED	Green LED	Green LED	Green LED	Green LED
Protective circuit	Rectifier	Rectifier	Rectifier	Rectifier, RC element	Rectifier, RC element

Ordering data					
PUSH IN connection Type	TOP 60VUC 48VDC0.1A	TOP 120VUC 48VDC0.1A	TOP 230VUC 48VDC0.1A	TOP 120VAC RC 48VDC0.1A	TOP 230VAC RC 48VDC0.1A
Order No.	<b>2614880000</b>	<b>2618680000</b>	<b>2618690000</b>	<b>2618650000</b>	<b>2618620000</b>
Screw connection Type	TOS 60VUC 48VDC0.1A	TOS 120VUC 48VDC0.1A	TOS 230VUC 48VDC0.1A	TOS 120VAC RC 48VDC0.1A	TOS 230VAC RC 48VDC0.1A
Order No.	<b>1126970000</b>	<b>1126980000</b>	<b>1126990000</b>	<b>1127000000</b>	<b>1127010000</b>
Note					

**Solid-state relay, 3...33 V DC / 2 A**

**Output versions**

- Space saving, just 6.4 mm modular width
- 2 A DC Output current
- PUSH IN and screw connection

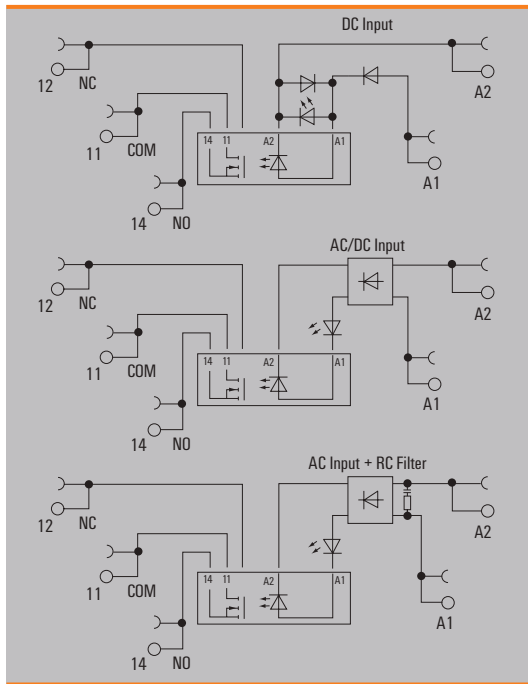

**Technical data**

Load side		
Rated switching voltage	3...33 V DC	
Continuous current	2 A	
Inrush current	15 A / 10 ms	
Contact type	1 NO contact (MOS-FET)	
Voltage drop at max. load	≤ 120 mV	
Leakage current	<10 µA	
Short-circuit-proof / Protective circuit, load side	No / Free-wheeling diode, Reverse polarity protection	
General data		
Ambient temperature (operational)	-20 °C...60 °C	
Storage temperature	-40 °C...70 °C	
Humidity	5-95% relative humidity, T <sub>90</sub> = 40°C, without condensation	
Approvals	CE; cULus; DETNORVER; UKCA	
Insulation coordinates		
Rated voltage	300 V	
Impulse withstand voltage	6 kV (1.2/50 µs)	
Dielectric strength for control side - load side	2.5 kV <sub>eff</sub>	
Dielectric strength to mounting rail	4 kV <sub>eff</sub> / 1 Min.	
Clearance and creepage distances for control side - load side	≥ 5.5 mm	
Overvoltage category	III	
Pollution degree	2	
Dimensions		
	<b>PUSH IN connection</b>	<b>Screw connection</b>
Clamping range (nominal / min. / max.)	mm <sup>2</sup> 1.5 / 0.14 / 2.5	1.5 / 0.14 / 2.5
Depth x width x height	mm 87.8 / 6.4 / 89.4	87.8 / 6.4 / 89.6
<b>Note</b>	Accessories and dimensional drawings: refer to the TERMSERIES Accessories page. Further approvals and technical data can be found at <a href="http://eshop.weidmueller.com">eshop.weidmueller.com</a>	

Solid-state relay, 3...33 V DC / 2 A

Output versions

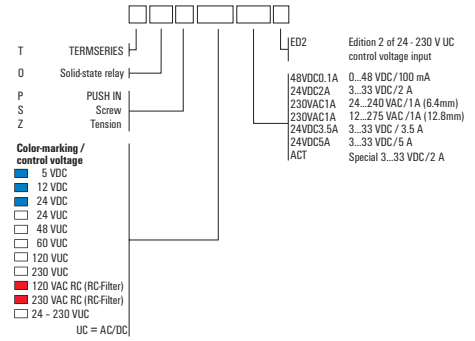

Ordering data

	5 V DC	12 V DC	24 V DC	24 V UC	48 V UC
<b>Control side</b>					
Rated control voltage	5 V DC $\pm 20\%$	12 V DC $\pm 20\%$	24 V DC $\pm 20\%$	24 V UC $\pm 10\%$	48 V UC $\pm 10\%$
Nominal control current	11.5 mA DC ( $\pm 20\%$ )	9.6 mA DC ( $\pm 20\%$ )	11.5 mA DC ( $\pm 10\%$ )	10 mA AC $\pm 20\%$ , 6 mA DC ( $\pm 20\%$ )	8 mA AC ( $\pm 20\%$ ), 7 mA DC ( $\pm 20\%$ )
Power rating	50 mW	112 mW	280 mW	154 mW	290 mVA / 192 mW
max. switching frequency (DC control voltage)	300 Hz	300 Hz	300 Hz	10 Hz	10 Hz
max. switching frequency (AC control voltage)				3 Hz	3 Hz
Status indicator	Green LED	Green LED	Green LED	Green LED	Green LED
Protective circuit	Free-wheeling diode, Reverse polarity protection	Free-wheeling diode, Reverse polarity protection	Free-wheeling diode, Reverse polarity protection	Rectifier	Rectifier

Ordering data					
PUSH IN connection Type	TOP 5VDC 24VDC2A	TOP 12VDC 24VDC2A	TOP 24VDC 24VDC2A	TOP 24VUC 24VDC2A	TOP 48VUC 24VDC2A
Order No.	<b>2618810000</b>	<b>2618820000</b>	<b>2618720000</b>	<b>2618730000</b>	<b>2618760000</b>
Screw connection Type	TOS 5VDC 24VDC2A	TOS 12VDC 24VDC2A	TOS 24VDC 24VDC2A	TOS 24VUC 24VDC2A	TOS 48VUC 24VDC2A
Order No.	<b>1127140000</b>	<b>1127150000</b>	<b>1127170000</b>	<b>1127180000</b>	<b>1127190000</b>
Note					

Ordering data

	60 V UC	120 V UC	230 V UC	120 V AC RC	230 V AC RC
<b>Control side</b>					
Rated control voltage	60 V UC $\pm 10\%$	120 V UC $\pm 10\%$	230 V UC $\pm 10\%$	120 V AC $\pm 10\%$	230 V AC $\pm 10\%$
Nominal control current	4.8 mA AC ( $\pm 10\%$ ), 2.5 mA DC ( $\pm 10\%$ )	4.1 mA AC ( $\pm 10\%$ ), 2.6 mA DC ( $\pm 10\%$ )	3.5 mA AC ( $\pm 5\%$ ), 2.9 mA DC ( $\pm 5\%$ )	7 mA AC ( $\pm 20\%$ )	9 mA AC
Power rating	150 mW, 290 mVA	0.49 VA, 0.31 W	670 mW, 805 mVA	0.84 VA	1.9 VA
max. switching frequency (DC control voltage)	10 Hz	10 Hz	3 Hz		
max. switching frequency (AC control voltage)	3 Hz	10 Hz	3 Hz	3 Hz	3 Hz
Status indicator	Green LED	Green LED	Green LED	Green LED	Green LED
Protective circuit	Rectifier	Rectifier	Rectifier	RC element	RC element

Ordering data					
PUSH IN connection Type	TOP 60VUC 24VDC2A	TOP 120VUC 24VDC2A	TOP 230VUC 24VDC2A	TOP 120VAC RC 24VDC2A	TOP 230VAC RC 24VDC2A
Order No.	<b>2618970000</b>	<b>2618770000</b>	<b>2618800000</b>	<b>2618660000</b>	<b>2618670000</b>
Screw connection Type	TOS 60VUC 24VDC2A	TOS 120VUC 24VDC2A	TOS 230VUC 24VDC2A	TOS 120VAC RC 24VDC2A	TOS 230VAC RC 24VDC2A
Order No.	<b>1127200000</b>	<b>1127210000</b>	<b>1127220000</b>	<b>1127230000</b>	<b>1127240000</b>
Note					

**Solid-state relay, 24...230 V AC / 1 A**

**Output versions**

- Space saving, just 6.4 mm modular width
- 1 A AC Output current
- PUSH IN and screw connection

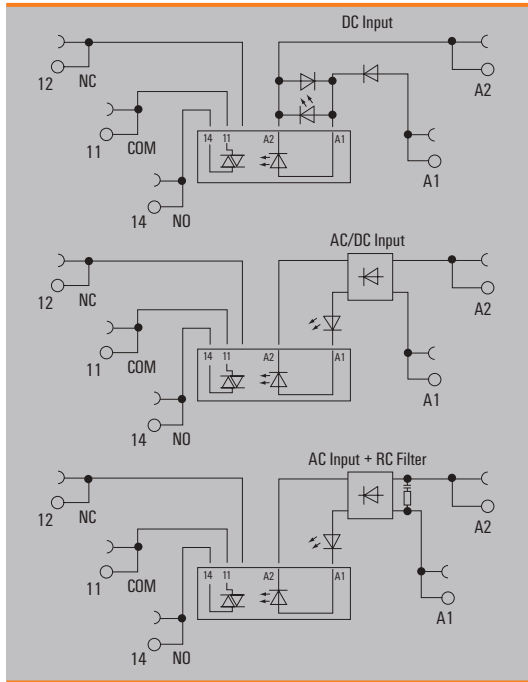

**Technical data**

Load side	
Rated switching voltage	24...240 V AC
Continuous current	1 A
Inrush current	15 A / 10 ms
Contact type	1 NO contact (Triac (zero-cross switch))
Voltage drop at max. load	≤ 1.6 V
Leakage current	<1.5 mA
Short-circuit-proof / Protective circuit, load side	No / RC element

General data	
Ambient temperature (operational)	-20 °C...60 °C
Storage temperature	-40 °C...70 °C
Humidity	5-95% relative humidity, T <sub>0</sub> = 40°C, without condensation
Approvals	CE; cULus; DETNORVER; UKCA

Insulation coordinates	
Rated voltage	300 V
Impulse withstand voltage	6 kV (1.2/50 µs)
Dielectric strength for control side - load side	2.5 kV <sub>eff</sub>
Dielectric strength to mounting rail	4 kV <sub>eff</sub> / 1 Min.
Clearance and creepage distances for control side - load side	≥ 5.5 mm
Overvoltage category	III
Pollution degree	2

Dimensions	PUSH IN connection	Screw connection
Clamping range (nominal / min. / max.)	mm <sup>2</sup> 1.5 / 0.14 / 2.5	1.5 / 0.14 / 2.5
Depth x width x height	mm 87.8 / 6.4 / 89.4	87.8 / 6.4 / 89.6

**Note** Accessories and dimensional drawings: refer to the TERMSERIES Accessories page. Further approvals and technical data can be found at [eshop.weidmueller.com](http://eshop.weidmueller.com)

Solid-state relay, 24...230 V AC / 1 A

Output versions

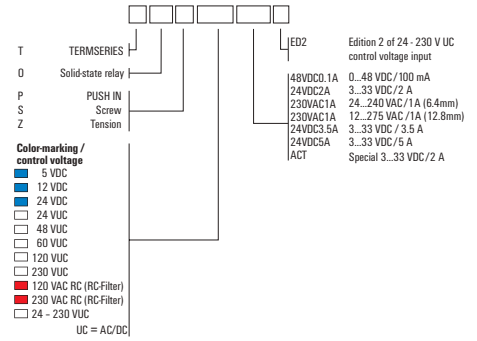

Ordering data

Control side	5 V DC	12 V DC	24 V DC	24 V UC	48 V UC
Rated control voltage	5 V DC $\pm 20\%$	12 V DC $\pm 20\%$	24 V DC $\pm 20\%$	24 V UC $\pm 10\%$	48 V UC $\pm 10\%$
Nominal control current	15 mA DC ( $\pm 20\%$ )	9.6 mA DC ( $\pm 20\%$ )	11.5 mA DC ( $\pm 10\%$ )	10 mA AC $\pm 20\%$ , 6 mA DC ( $\pm 20\%$ )	6 mA AC ( $\pm 20\%$ ), 4 mA DC ( $\pm 20\%$ )
Power rating	75 mW	112 mW	280 mW	154 mW	290 mVA / 192 mW
max. switching frequency (DC control voltage)	3 Hz	3 Hz	3 Hz	3 Hz	3 Hz
max. switching frequency (AC control voltage)				3 Hz	3 Hz
Status indicator	Green LED	Green LED	Green LED	Green LED	Green LED
Protective circuit	Free-wheeling diode, Reverse polarity protection	Free-wheeling diode, Reverse polarity protection	Free-wheeling diode, Reverse polarity protection	Rectifier	Rectifier

Ordering data					
PUSH IN connection Type	TOP 5VDC 230VAC1A	TOP 12VDC 230VAC1A	TOP 24VDC 230VAC1A	TOP 24VUC 230VAC1A	TOP 48VUC 230VAC1A
Order No.	<b>2614850000</b>	<b>2618380000</b>	<b>2618420000</b>	<b>2618350000</b>	<b>2618460000</b>
Screw connection Type	TOS 5VDC 230VAC1A	TOS 12VDC 230VAC1A	TOS 24VDC 230VAC1A	TOS 24VUC 230VAC1A	TOS 48VUC 230VAC1A
Order No.	<b>1127390000</b>	<b>1127400000</b>	<b>1127410000</b>	<b>1127420000</b>	<b>1127430000</b>
Note					

Ordering data

Control side	60 V UC	120 V UC	230 V UC	120 V AC RC	230 V AC RC
Rated control voltage	60 V UC $\pm 10\%$	120 V UC $\pm 10\%$	230 V UC $+5\% / -10\%$	120 V AC $\pm 10\%$	230 V AC $+5\% / -10\%$
Nominal control current	4.8 mA AC ( $\pm 10\%$ ), 2.5 mA DC ( $\pm 10\%$ )	5 mA AC ( $\pm 30\%$ ), 3 mA DC ( $\pm 30\%$ )	3.5 mA AC ( $\pm 5\%$ ), 2.9 mA DC ( $\pm 5\%$ )	7 mA AC ( $\pm 20\%$ )	8.3 mA AC ( $\pm 5\%$ )
Power rating	<300 mW	0.48 VA	0.8 VA / 660 mW	0.84 VA	2.1 VA
max. switching frequency (DC control voltage)	3 Hz	3 Hz	3 Hz		
max. switching frequency (AC control voltage)	3 Hz	3 Hz	3 Hz	3 Hz	3 Hz
Status indicator	Green LED	Green LED	Green LED	Green LED	Green LED
Protective circuit	Rectifier	Rectifier	Rectifier	RC element	RC element

Ordering data					
PUSH IN connection Type	TOP 60VUC 230VAC1A	TOP 120VUC 230VAC1A	TOP 230VUC 230VAC1A	TOP 120VAC RC 230VAC1A	TOP 230VAC RC 230VAC1A
Order No.	<b>2618370000</b>	<b>2618480000</b>	<b>2618450000</b>	<b>2618390000</b>	<b>2618430000</b>
Screw connection Type	TOS 60VUC 230VAC1A	TOS 120VUC 230VAC1A	TOS 230VUC 230VAC1A	TOS 120VAC RC 230VAC1A	TOS 230VAC RC 230VAC1A
Order No.	<b>1127440000</b>	<b>1127450000</b>	<b>1127470000</b>	<b>1127480000</b>	<b>1127490000</b>
Note					

**1 CO contact**  
**AC/DC/UC coil**

- Space-saving, only 6.4 mm wide
- AgNi contact
- PUSH IN and screw connection

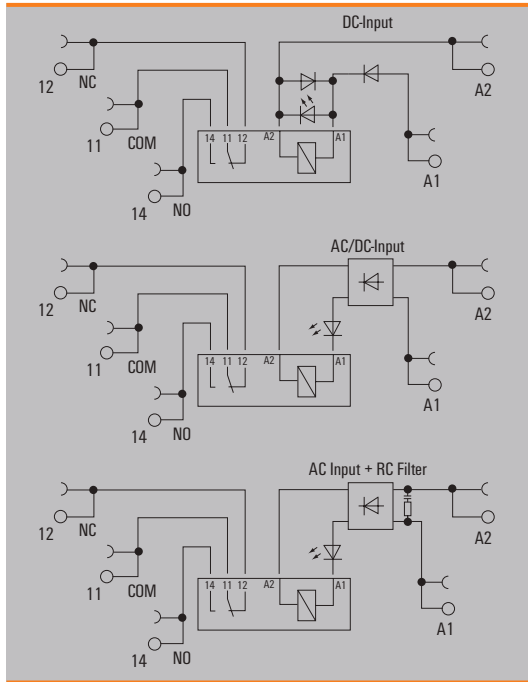
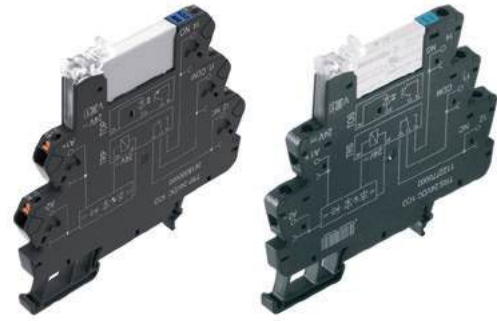

**Technical data**

Load side	
Rated switching voltage / Continuous current	250 V AC / 6 A
Max. switching voltage, AC	250 V
Inrush current	20 A / 20 ms
Min. switching power	1 mA @ 24 V, 10 mA @ 12 V, 100 mA @ 5 V
Contact type	1 CO contact (AgNi)
Mechanical service life	5 x 10 <sup>6</sup> switching cycles
Max. switching frequency at rated load	0.1 Hz
General data	
Ambient temperature (operational)	-40 °C...60 °C
Storage temperature	-40 °C...85 °C
Humidity	5-95% relative humidity, T <sub>90</sub> = 40°C, without condensation
Approvals	CE; cULus; DETNORVER; UKCA
Insulation coordinates	
Rated voltage	300 V
Impulse withstand voltage	6 kV (1.2/50 µs)
Dielectric strength for control side - load side	4 kV <sub>eff</sub> / 1 Min.
Dielectric strength of neighbouring contacts	
Dielectric strength to mounting rail	4 kV <sub>eff</sub> / 1 Min.
Clearance and creepage distances for control side - load side	≥ 6 mm
Overvoltage category	III
Pollution degree	2
Dimensions	
Clamping range (nominal / min. / max.)	mm <sup>2</sup> 1.5 / 0.14 / 2.5
Depth x width x height	mm 87.8 / 6.4 / 89.4
	mm 87.8 / 6.4 / 89.6
Note	
Accessories and dimensional drawings: refer to the TERMSERIES Accessories page. Further approvals and technical data can be found at <a href="http://eshop.weidmuller.com">eshop.weidmuller.com</a>	

**Applications**

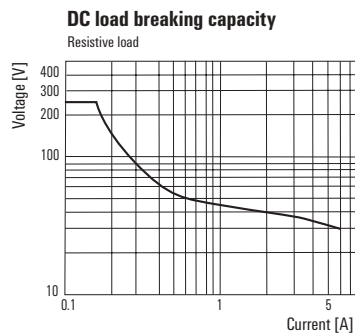
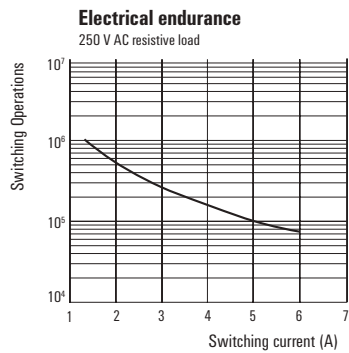

**1 CO contact**  
**AC/DC/UC coil**

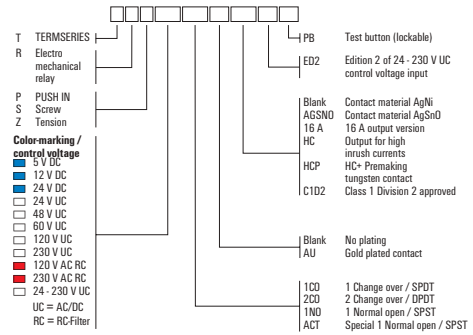

**Ordering data**

	5 V DC	12 V DC	24 V DC	24 V UC	48 V UC
<b>Control side</b>					
Rated control voltage	5 V DC ± 20 %	12 V DC ± 20 %	24 V DC ± 20 %	24 V UC ± 10 %	48 V UC ± 10 %
Rated current AC / DC	/ 33 mA	/ 18 mA	/ 11.5 mA	11.7 mA / 6.4 mA	8 mA / 7 mA
Power rating	170 mW	210 mW	280 mW	270 mVA / 154 mW	340 mW / 0.4 VA
Status indicator	Green LED	Green LED	Green LED	Green LED	Green LED
Protective circuit	Free-wheeling diode, Reverse polarity protection	Free-wheeling diode, Reverse polarity protection	Free-wheeling diode, Reverse polarity protection	Rectifier	Rectifier

Ordering data					
PUSH IN connection Type	TRP 5VDC 1CO	TRP 12VDC 1CO	TRP 24VDC 1CO	TRP 24VUC 1CO	TRP 48VUC 1CO
Order No.	<b>2614830000</b>	<b>2618180000</b>	<b>2618000000</b>	<b>2618220000</b>	<b>2618240000</b>
Screw connection Type	TRS 5VDC 1CO	TRS 12VDC 1CO	TRS 24VDC 1CO	TRS 24VUC 1CO	TRS 48VUC 1CO
Order No.	<b>1122740000</b>	<b>1122750000</b>	<b>1122770000</b>	<b>1122780000</b>	<b>1122790000</b>
Note					

**Ordering data**

	60 V UC	120 V UC	230 V UC	120 V AC RC	230 V AC RC
<b>Control side</b>					
Rated control voltage	60 V UC ± 10 %	120 V UC ± 10 %	230 V UC ± 10 %	120 V AC ± 10 %	230 V AC ± 10 %
Rated current AC / DC	4,8 mA / 2,8 mA	4 mA / 3,5 mA	3,5 mA / 2,9 mA	7 mA /	8,5 mA /
Power rating	170 mW, 290 mVA	0,48 VA, 420 mW	670 mW, 805 mVA	840 mVA	2 VA
Status indicator	Green LED	Green LED	Green LED	Green LED	Green LED
Protective circuit	Rectifier	Rectifier	Rectifier	Rectifier, RC element	Rectifier, RC element

Ordering data					
PUSH IN connection Type	TRP 60VUC 1CO	TRP 120VUC 1CO	TRP 230VUC 1CO	TRP 120VAC RC 1CO	TRP 230VAC RC 1CO
Order No.	<b>2618140000</b>	<b>2618010000</b>	<b>2618050000</b>	<b>2618150000</b>	<b>2618200000</b>
Screw connection Type	TRS 60VUC 1CO	TRS 120VUC 1CO	TRS 230VUC 1CO	TRS 120VAC RC 1CO	TRS 230VAC RC 1CO
Order No.	<b>1122800000</b>	<b>1122810000</b>	<b>1122820000</b>	<b>1122830000</b>	<b>1122840000</b>
Note					

**1 CO contact with hard gold-plated contacts**  
**AC/DC/UC coil**

- Space saving, just 6.4 mm modular width
- AgNi contact with gold plating
- PUSH IN and screw connection

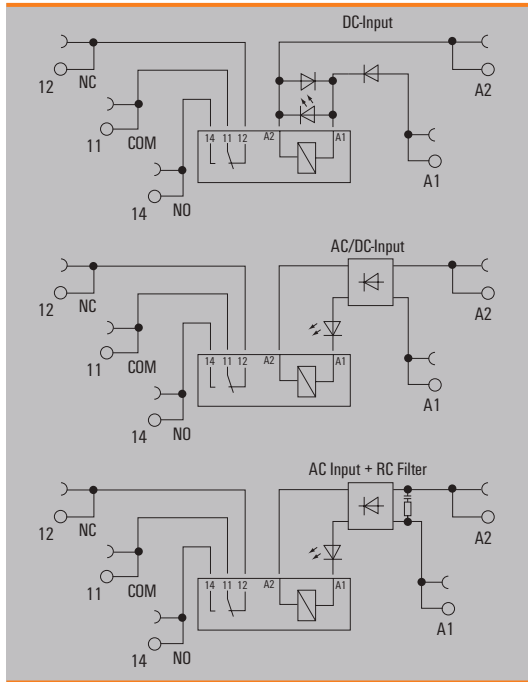
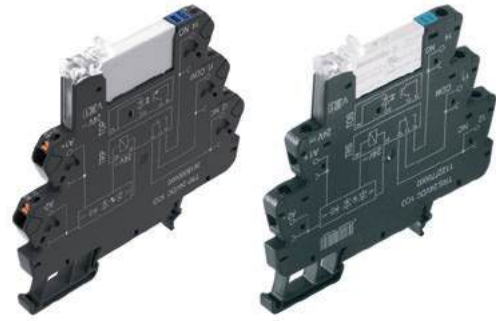

**Technical data**

Load side	
Rated switching voltage / Continuous current	250 V AC / 6 A
Max. switching voltage, AC	250 V
Inrush current	20 A / 20 ms
Min. switching power	1 mA @ 1 V
Contact type	1 CO contact (AgNi gold-plated)
Mechanical service life	5 x 10 <sup>6</sup> switching cycles
Max. switching frequency at rated load	0.1 Hz
General data	
Ambient temperature (operational)	-40 °C...60 °C
Storage temperature	-40 °C...85 °C
Humidity	5-95% relative humidity, T <sub>0</sub> = 40°C, without condensation
Approvals	CE; cULus; DETNORVER; UKCA
Insulation coordinates	
Rated voltage	300 V
Impulse withstand voltage	6 kV (1.2/50 µs)
Dielectric strength for control side - load side	4 kV <sub>eff</sub> / 1 Min.
Dielectric strength of neighbouring contacts	
Dielectric strength to mounting rail	4 kV <sub>eff</sub> / 1 Min.
Clearance and creepage distances for control side - load side	≥ 6 mm
Overvoltage category	III
Pollution degree	2
Dimensions	
Clamping range (nominal / min. / max.)	mm <sup>2</sup> 1.5 / 0.14 / 2.5
Depth x width x height	mm 87.8 / 6.4 / 89.4
	mm 87.8 / 6.4 / 89.6
Note	
Accessories and dimensional drawings: refer to the TERMSERIES Accessories page. Further approvals and technical data can be found at <a href="http://eshop.weidmueller.com">eshop.weidmueller.com</a>	

**Applications**

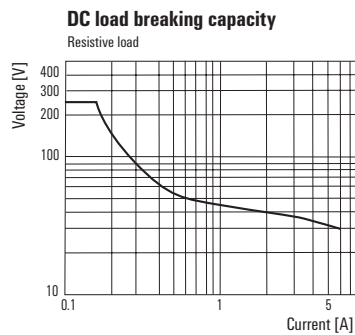
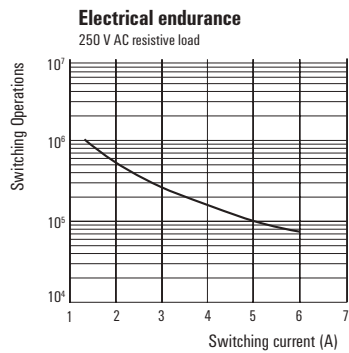

1 CO contact with hard gold-plated contacts  
AC/DC/UC coil

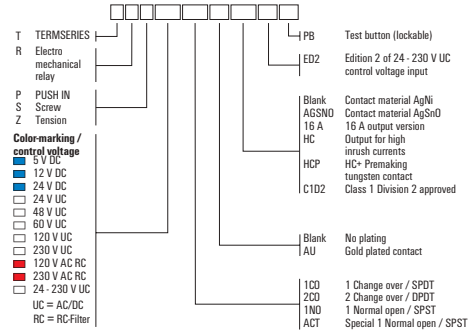

Ordering data

Control side	5 V DC	12 V DC	24 V DC	24 V UC	48 V UC
Rated control voltage	5 V DC ± 20 %	12 V DC ± 20 %	24 V DC ± 20 %	24 V UC ± 10 %	48 V UC ± 10 %
Rated current AC / DC	/ 33 mA	/ 18 mA	/ 11.5 mA	11.7 mA / 6.4 mA	8 mA / 7 mA
Power rating	170 mW	210 mW	280 mW	270 mVA / 154 mW	340 mW / 0.4 VA
Status indicator	Green LED	Green LED	Green LED	Green LED	Green LED
Protective circuit	Free-wheeling diode, Reverse polarity protection	Free-wheeling diode, Reverse polarity protection	Free-wheeling diode, Reverse polarity protection	Rectifier	Rectifier

Ordering data						
PUSH IN connection	Type	TRP 5VDC 1CO AU	TRP 12VDC 1CO AU	TRP 24VDC 1CO AU	TRP 24VUC 1CO AU	TRP 48VUC 1CO AU
	Order No.	2618060000	2618120000	2618110000	2618160000	2618170000
Screw connection	Type	TRS 5VDC 1CO AU	TRS 12VDC 1CO AU	TRS 24VDC 1CO AU	TRS 24VUC 1CO AU	TRS 48VUC 1CO AU
	Order No.	1122980000	1122990000	1123000000	1123010000	1123020000
Note						

Ordering data

Control side	60 V UC	120 V UC	230 V UC	120 V AC RC	230 V AC RC
Rated control voltage	60 V UC ± 10 %	120 V UC ± 10 %	230 V UC ± 10 %	120 V AC ± 10 %	230 V AC ± 10 %
Rated current AC / DC	4,8 mA / 2,8 mA	4 mA / 3,5 mA	3,5 mA / 2,9 mA	7 mA /	8,5 mA /
Power rating	170 mW, 290 mVA	0,48 VA, 420 mW	670 mW, 805 mVA	840 mVA	2 VA
Status indicator	Green LED	Green LED	Green LED	Green LED	Green LED
Protective circuit	Rectifier	Rectifier	Rectifier	Rectifier, RC element	Rectifier, RC element

Ordering data						
PUSH IN connection	Type	TRP 60VUC 1CO AU	TRP 120VUC 1CO AU	TRP 230VUC 1CO AU	TRP 120VAC RC 1CO AU	TRP 230VAC RC 1CO AU
	Order No.	2618070000	2618080000	2618210000	2618030000	2617950000
Screw connection	Type	TRS 60VUC 1CO AU	TRS 120VUC 1CO AU	TRS 230VUC 1CO AU	TRS 120VAC RC 1CO AU	TRS 230VAC RC 1CO AU
	Order No.	1123030000	1123040000	1123050000	1123070000	1123080000
Note						

**1 CO contact (AgSnO)**

**AC / DC / UC coil**

- Space-saving, only 6.4 mm wide
- AgSnO contact
- For capacitive and inductive loads
- PUSH IN and screw connection

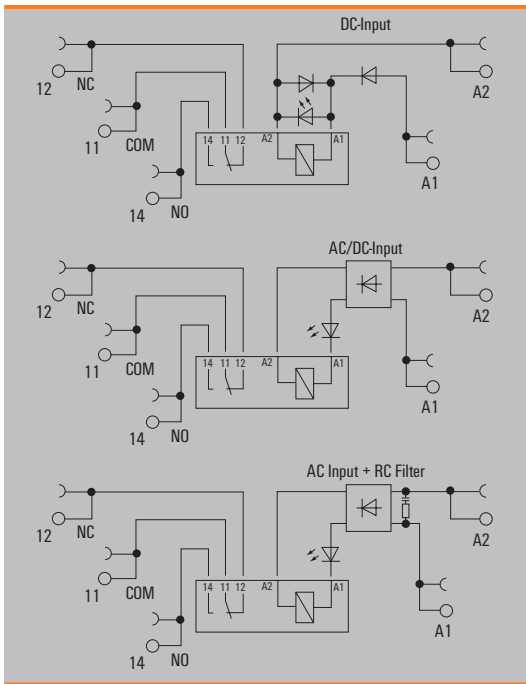
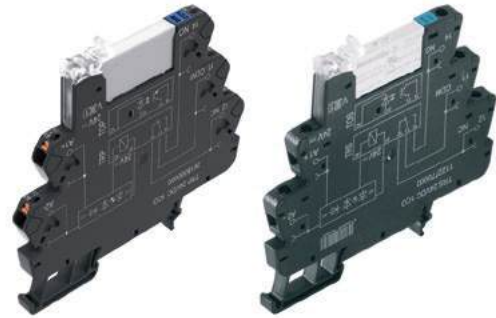

**Technical data**

Load side	
Rated switching voltage / Continuous current	250 V AC / 6 A
Max. switching voltage, AC	250 V
Inrush current	30 A / 20 ms
Min. switching power	100 mA @ 12 V
Contact type	1 CO contact (AgSnO)
Mechanical service life	5 x 10 <sup>6</sup> switching cycles
Max. switching frequency at rated load	0.1 Hz
General data	
Ambient temperature (operational)	-40 °C...60 °C
Storage temperature	-40 °C...85 °C
Humidity	5-95% relative humidity, T <sub>90</sub> = 40°C, without condensation
Approvals	CE; cULus; DETNORVER; UKCA
Insulation coordinates	
Rated voltage	300 V
Impulse withstand voltage	6 kV (1.2/50 µs)
Dielectric strength for control side - load side	4 kV <sub>eff</sub> / 1 Min.
Dielectric strength of neighbouring contacts	
Dielectric strength to mounting rail	4 kV <sub>eff</sub> / 1 Min.
Clearance and creepage distances for control side - load side	≥ 6 mm
Overvoltage category	III
Pollution degree	2
Dimensions	
Clamping range (nominal / min. / max.)	mm <sup>2</sup> 1.5 / 0.14 / 2.5
Depth x width x height	mm 87.8 / 6.4 / 89.4
	mm 87.8 / 6.4 / 89.6
Note	
Accessories and dimensional drawings: refer to the TERMSERIES Accessories page. Further approvals and technical data can be found at <a href="http://eshop.weidmueller.com">eshop.weidmueller.com</a>	

**Applications**

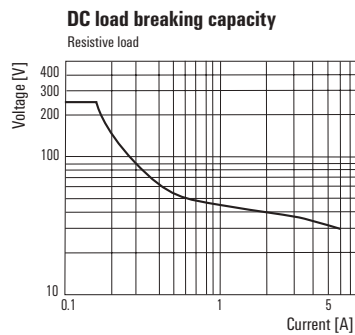
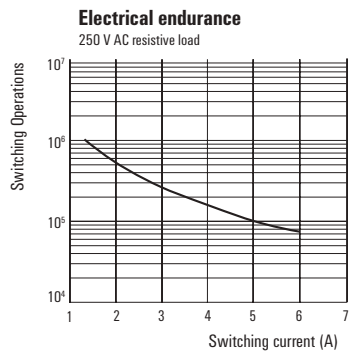

**1 CO contact (AgSnO)**  
**AC / DC / UC coil**

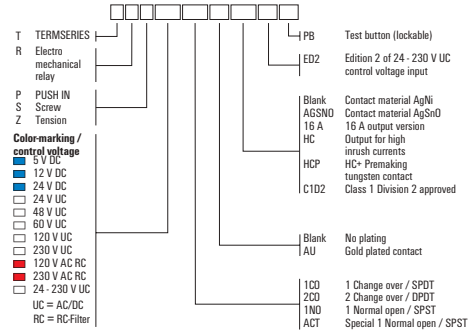

**Ordering data**

Control side	5 V DC	12 V DC	24 V DC	24 V UC	48 V UC
Rated control voltage	5 V DC ± 20 %	12 V DC ± 20 %	24 V DC ± 20 %	24 V UC ± 10 %	48 V UC ± 10 %
Rated current AC / DC	/ 33 mA	/ 18 mA	/ 11.5 mA	11.7 mA / 6.4 mA	8 mA / 7 mA
Power rating	170 mW	210 mW	280 mW	270 mVA / 154 mW	340 mW / 0.4 VA
Status indicator	Green LED	Green LED	Green LED	Green LED	Green LED
Protective circuit	Free-wheeling diode, Reverse polarity protection	Free-wheeling diode, Reverse polarity protection	Free-wheeling diode, Reverse polarity protection	Rectifier	Rectifier

**Ordering data**

PUSH IN connection	Type	TRP 5VDC 1CO AGSNO	TRP 12VDC 1CO AGSNO	TRP 24VDC 1CO AGSNO	TRP 24VUC 1CO AGSNO	TRP 48VUC 1CO AGSNO
Order No.		<b>2614820000</b>	<b>2617860000</b>	<b>2618020000</b>	<b>2617880000</b>	<b>2617890000</b>
Screw connection	Type	TRS 5VDC 1CO AGSNO	TRS 12VDC 1CO AGSNO	TRS 24VDC 1CO AGSNO	TRS 24VUC 1CO AGSNO	TRS 48VUC 1CO AGSNO
Order No.		<b>2152860000</b>	<b>2152880000</b>	<b>1984540000</b>	<b>2152940000</b>	<b>2153060000</b>

**Note**

**Ordering data**

Control side	60 V UC	120 V UC	230 V UC	120 V AC RC	230 V AC RC
Rated control voltage	60 V UC ± 10 %	120 V UC ± 10 %	230 V UC ± 10 %	120 V AC ± 10 %	230 V AC ± 10 %
Rated current AC / DC	4,8 mA / 2,8 mA	4 mA / 3,5 mA	3,5 mA / 2,9 mA	7 mA /	8,8 mA /
Power rating	170 mW, 290 mVA	0,48 VA, 420 mW	670 mW, 805 mVA	840 mVA	2 VA
Status indicator	Green LED	Green LED	Green LED	Green LED	Green LED
Protective circuit	Rectifier	Rectifier	Rectifier	Rectifier, RC element	Rectifier, RC element

**Ordering data**

PUSH IN connection	Type	TRP 60VUC 1CO AGSNO	TRP 120VUC 1CO AGSNO	TRP 230VUC 1CO AGSNO	TRP 120VAC RC 1CO AGSNO	TRP 230VAC RC 1CO AGSNO
Order No.		<b>2617870000</b>	<b>2617900000</b>	<b>2617830000</b>	<b>2617840000</b>	<b>2617850000</b>
Screw connection	Type	TRS 60VUC 1CO AGSNO	TRS 120VUC 1CO AGSNO	TRS 230VUC 1CO AGSNO	TRS 120VAC RC 1CO AGSNO	TRS 230VAC RC 1CO AGSNO
Order No.		<b>2153550000</b>	<b>2153570000</b>	<b>2153590000</b>	<b>2152900000</b>	<b>2152920000</b>

**Note**

2 CO contacts

AC/DC/UC coil

- Space saving, just 12.8 mm modular width
- AgNi contact
- PUSH IN and screw connection

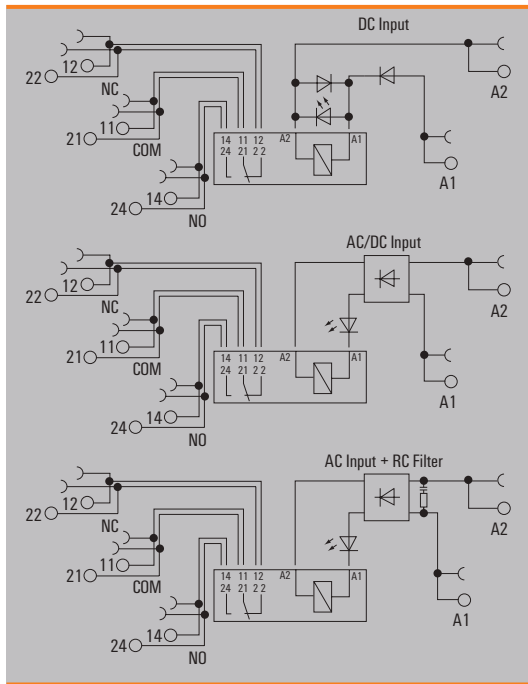

Technical data

Load side	
Rated switching voltage / Continuous current	250 V AC / 8 A
Max. switching voltage, AC	250 V
Inrush current	15 A / 4 s
Min. switching power	1 mA @ 24 V, 10 mA @ 10 V, 100 mA @ 5 V
Contact type	2 CO contact (AgNi)
Mechanical service life	30 x 10 <sup>6</sup> switching cycles
Max. switching frequency at rated load	0.1 Hz
General data	
Ambient temperature (operational)	-40 °C...60 °C
Storage temperature	-40 °C...85 °C
Humidity	5-95% relative humidity, T <sub>90</sub> = 40°C, without condensation
Approvals	CE; cULus; DETNORVER; UKCA
Insulation coordinates	
Rated voltage	300 V
Impulse withstand voltage	6 kV (1.2/50 µs)
Dielectric strength for control side - load side	3.51 kV <sub>eff</sub> / 1 min.
Dielectric strength of neighbouring contacts	2.5 kV <sub>eff</sub> / 1 Min.
Dielectric strength to mounting rail	4 kV <sub>eff</sub> / 1 Min.
Clearance and creepage distances for control side - load side	≥ 6 mm
Overvoltage category	III
Pollution degree	2

Dimensions	PUSH IN	Screw connection
Clamping range (nominal / min. / max.)	mm <sup>2</sup> 1.5 / 0.14 / 2.5	1.5 / 0.14 / 2.5
Depth x width x height	mm 87.8 / 12.8 / 89.4	87.8 / 12.8 / 89.6
Note	Accessories and dimensional drawings: refer to the TERMSERIES Accessories page. Further approvals and technical data can be found at eshop.weidmuller.com	

Applications

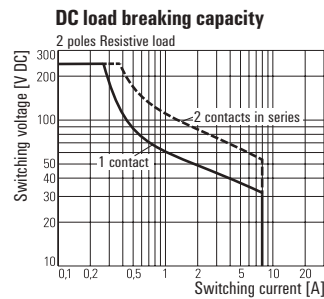
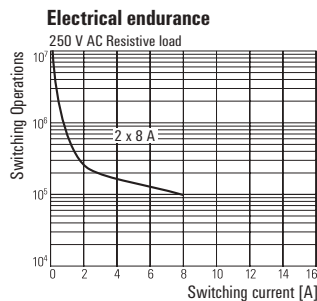

**2 CO contacts**  
**AC/DC/UC coil**

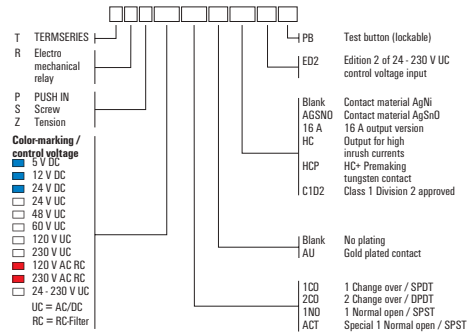

**Ordering data**

Control side	5 V DC	12 V DC	24 V DC	24 V UC	48 V UC
Rated control voltage	5 V DC ± 20 %	12 V DC ± 20 %	24 V DC ± 20 %	24 V UC ± 10 %	48 V UC ± 10 %
Rated current AC / DC	/ 70 mA	/ 33 mA	/ 20.5 mA	16 mA / 14 mA	9 mA / 7 mA
Power rating	400 mW	400 mW	495 mW	390 mVA / 350 mW	340 mW / 0.4 VA
Status indicator	Green LED	Green LED	Green LED	Green LED	Green LED
Protective circuit	Free-wheeling diode, Reverse polarity protection	Free-wheeling diode, Reverse polarity protection	Free-wheeling diode, Reverse polarity protection	Rectifier	Rectifier

Ordering data					
PUSH IN connection Type	TRP 5VDC 2CO	TRP 12VDC 2CO	TRP 24VDC 2CO	TRP 24VUC 2CO	TRP 48VUC 2CO
Order No.	<b>2614840000</b>	<b>2618550000</b>	<b>2618400000</b>	<b>2618320000</b>	<b>2618520000</b>
Screw connection Type	TRS 5VDC 2CO	TRS 12VDC 2CO	TRS 24VDC 2CO	TRS 24VUC 2CO	TRS 48VUC 2CO
Order No.	<b>1123470000</b>	<b>1123480000</b>	<b>1123490000</b>	<b>1123500000</b>	<b>1123510000</b>
Note					

**Ordering data**

Control side	60 V UC	120 V UC	230 V UC	120 V AC RC	230 V AC RC
Rated control voltage	60 V UC ± 10 %	120 V UC ± 10 %	230 V UC ± 5 %	120 V AC ± 10 %	230 V AC ± 5 %
Rated current AC / DC	8.3 mA / 6.0 mA	3.5 mA / 3.5 mA	5.5 mA / 4.4 mA	5.5 mA /	8.8 mA /
Power rating	360 mW, 500 mVA	420 mVA / 420 mW	1 W, 1.2 VA	0.6 VA	2.1 VA
Status indicator	Green LED	Green LED	Green LED	Green LED	Green LED
Protective circuit	Rectifier	Rectifier	Rectifier	Rectifier, RC element	Rectifier, RC element

Ordering data					
PUSH IN connection Type	TRP 60VUC 2CO	TRP 120VUC 2CO	TRP 230VUC 2CO	TRP 120VAC RC 2CO	TRP 230VAC RC 2CO
Order No.	<b>2618290000</b>	<b>2618570000</b>	<b>2618440000</b>	<b>2618470000</b>	<b>2618330000</b>
Screw connection Type	TRS 60VUC 2CO	TRS 120VUC 2CO	TRS 230VUC 2CO	TRS 120VAC RC 2CO	TRS 230VAC RC 2CO
Order No.	<b>1123520000</b>	<b>1123530000</b>	<b>1123540000</b>	<b>1123550000</b>	<b>1123570000</b>
Note					

2 CO contact with hard gold-plated contacts

AC/DC/UC coil

- Space saving, just 12.8 mm modular width
- AgNi contact with gold plating
- PUSH IN and screw connection

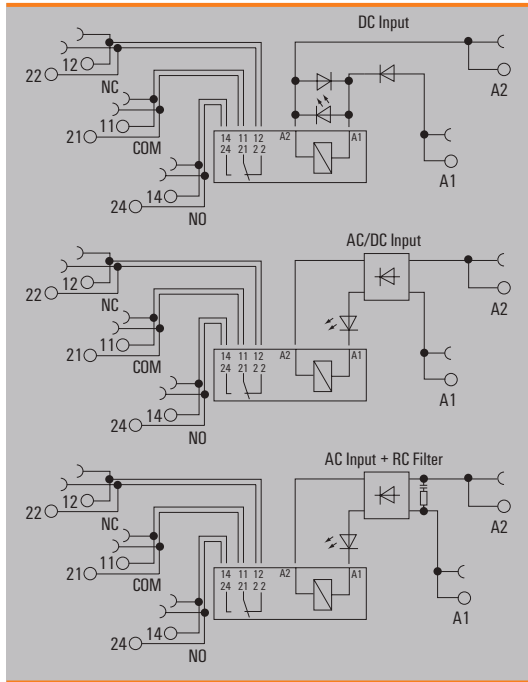

Technical data

Load side			
Rated switching voltage / Continuous current	250 V AC / 8 A		
Max. switching voltage, AC	250 V		
Inrush current	15 A / 4 s		
Min. switching power	1 mA @ 1 V		
Contact type	2 CO contact (AgNi gold-plated)		
Mechanical service life	30 x 10 <sup>6</sup> switching cycles		
Max. switching frequency at rated load	0.1 Hz		
General data			
Ambient temperature (operational)	-40 °C...60 °C		
Storage temperature	-40 °C...85 °C		
Humidity	5-95% relative humidity, T <sub>90</sub> = 40°C, without condensation		
Approvals	CE; cULus; DETNORVER; UKCA		
Insulation coordinates			
Rated voltage	300 V		
Impulse withstand voltage	6 kV (1.2/50 µs)		
Dielectric strength for control side - load side	3.51 kV <sub>eff</sub> / 1 min.		
Dielectric strength of neighbouring contacts	2.5 kV <sub>eff</sub> / 1 Min.		
Dielectric strength to mounting rail	4 kV <sub>eff</sub> / 1 Min.		
Clearance and creepage distances for control side - load side	≥ 6 mm		
Overvoltage category	III		
Pollution degree	2		
Dimensions			
Clamping range (nominal / min. / max.)	mm <sup>2</sup>	<b>PUSH IN</b>	<b>Screw connection</b>
		1.5 / 0.14 / 2.5	1.5 / 0.14 / 2.5
Depth x width x height	mm	87.8 / 12.8 / 89.4	87.8 / 12.8 / 89.6
Note			
Accessories and dimensional drawings: refer to the TERMSERIES Accessories page. Further approvals and technical data can be found at eshop.weidmuller.com			

Applications

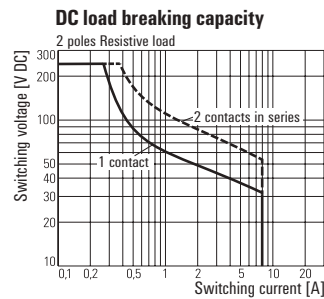
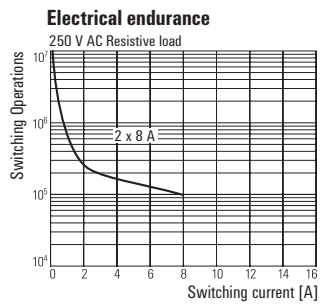

**2 CO contact with hard gold-plated contacts**  
**AC/DC/UC coil**

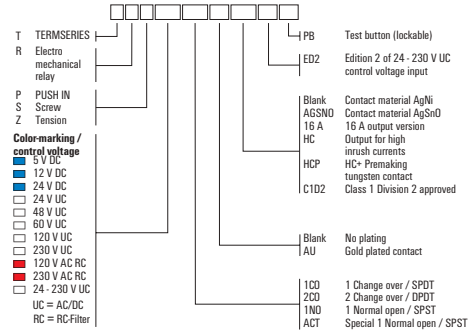

**Ordering data**

Control side	5 V DC	12 V DC	24 V DC	24 V UC	48 V UC
Rated control voltage	5 V DC ± 20 %	12 V DC ± 20 %	24 V DC ± 20 %	24 V UC ± 10 %	48 V UC ± 10 %
Rated current AC / DC	/ 70 mA	/ 33 mA	/ 20.5 mA	16 mA / 14 mA	9 mA / 7 mA
Power rating	400 mW	400 mW	495 mW	390 mVA / 350 mW	340 mW / 0.4 VA
Status indicator	Green LED	Green LED	Green LED	Green LED	Green LED
Protective circuit	Free-wheeling diode, Reverse polarity protection	Free-wheeling diode, Reverse polarity protection	Free-wheeling diode, Reverse polarity protection	Rectifier	Rectifier

Ordering data					
PUSH IN connection Type	TRP 5VDC 2CO AU	TRP 12VDC 2CO AU	TRP 24VDC 2CO AU	TRP 24VUC 2CO AU	TRP 48VUC 2CO AU
Order No.	<b>2618580000</b>	<b>2618310000</b>	<b>2618530000</b>	<b>2618540000</b>	<b>2618560000</b>
Screw connection Type	TRS 5VDC 2CO AU	TRS 12VDC 2CO AU	TRS 24VDC 2CO AU	TRS 24VUC 2CO AU	TRS 48VUC 2CO AU
Order No.	<b>1123710000</b>	<b>1123720000</b>	<b>1123730000</b>	<b>1123740000</b>	<b>1123750000</b>
Note					

**Ordering data**

Control side	60 V UC	120 V UC	230 V UC	120 V AC RC	230 V AC RC
Rated control voltage	60 V UC ± 10 %	120 V UC ± 10 %	230 V UC ± 5 %	120 V AC ± 10 %	230 V AC ± 5 %
Rated current AC / DC	8.3 mA / 6.0 mA	3.5 mA / 3.5 mA	5.5 mA / 4.4 mA	5.5 mA /	8.8 mA /
Power rating	360 mW, 500 mVA	420 mVA / 420 mW	1 W, 1.2 VA	0.6 VA	2.1 VA
Status indicator	Green LED	Green LED	Green LED	Green LED	Green LED
Protective circuit	Rectifier	Rectifier	Rectifier	Rectifier, RC element	Rectifier, RC element

Ordering data					
PUSH IN connection Type	TRP 60VUC 2CO AU	TRP 120VUC 2CO AU	TRP 230VUC 2CO AU	TRP 120VAC RC 2CO AU	TRP 230VAC RC 2CO AU
Order No.	<b>2618360000</b>	<b>2618590000</b>	<b>2618300000</b>	<b>2618490000</b>	<b>2618500000</b>
Screw connection Type	TRS 60VUC 2CO AU	TRS 120VUC 2CO AU	TRS 230VUC 2CO AU	TRS 120VAC RC 2CO AU	TRS 230VAC RC 2CO AU
Order No.	<b>1123770000</b>	<b>1123780000</b>	<b>1123790000</b>	<b>1123800000</b>	<b>1123810000</b>
Note					

## Timing functions

### Reliable timing relays for plant and building automation

#### C

Timing relays play an important role in many areas of plant and building automation. They are always used when switch-on or switch-off processes are to be delayed or when short pulses are to be extended. They are used, for example, to avoid errors during short switching cycles that cannot be reliably detected by downstream control components. Timing relays are also a simple way of integrating timer functions into a system without PLC, or implementing them without programming effort.

The Klippon® Relay portfolio provides you with relays for various timing functions such as on-delay, off-delay, clock generator and star-delta relays. We also offer timing relays for universal applications in factory and building automation as well as multifunction timing relays with several timer functions. Our timing relays are available as a classic building automation design, a compact 6.4 mm version and with wide-range multi-voltage input. Our timing relays have the current approvals according to DNV and cULus and can therefore be used internationally.



Visit our website for more information  
[www.weidmueller.com/tf](http://www.weidmueller.com/tf)

## TERMSERIES TIMER

### Timing relay for control signal adaptation with additional functions

#### C

Timing relays are used to coordinate fast switching processes in control systems, among other things. TERMSERIES TIMER timing relays have a on-delay, which allows for the delayed switch-on of machines, the cascaded start-up of system components or the delayed activation of consumers such as pumps or valves. They also have the One Shot and blinker functions.

TERMSERIES TIMER timing relays in compact 6.4 mm terminal block format are available with either a screw connection or a PUSH IN wire connection. The timing functions and time ranges can be conveniently adjusted via the DIP switches on the side. The power supply and the respective switching status can be checked at a glance by means of the clearly visible duo LED on the ejection lever. International approvals in accordance with EN 61812 mean that they can be used anywhere in the world. TERMSERIES TIMER is compatible with the wide range of TERMSERIES accessories, thereby ensuring high levels of flexibility and simple integration into existing systems.

#### Your special advantages:

- Control voltage 24 V DC
- Empty socket for solid-state relays and electromechanical relays
- Simple adjustment of timing functions and time ranges
- Multifunctional design with three time functions: on-delay, One Shot and blinker



**International approval**  
TERMSERIES timing relays comply with the requirements of EN 61812 and can be used anywhere in the world.



Available with screw connection and PUSH IN connection technology

**Comfortable adjustment**  
Timing function and time ranges are easy to adjust via the DIP switches on the side.

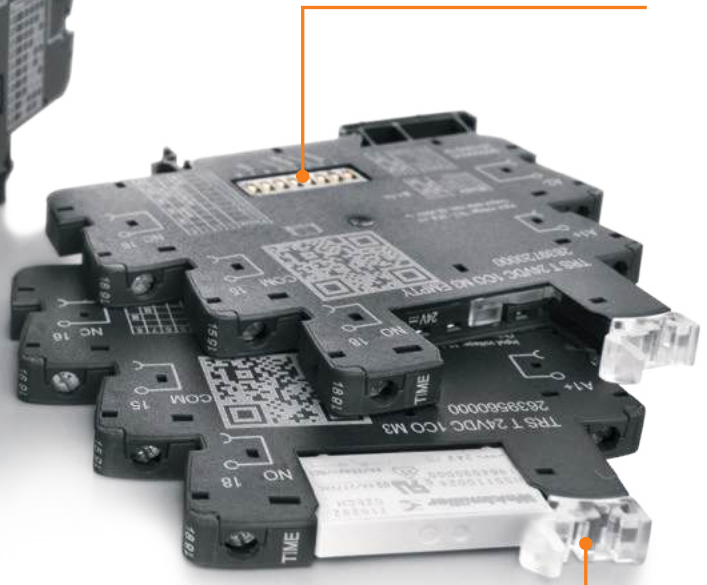

**Clear display**  
Due to the integrated Duo-LED on the ejection lever, power supply and switching status can be checked at a glance.

## Timing functions – TERMSERIES TIMER

### Complete modules

- Space-saving, 6.4 mm wide
- 3 time functions
- Complete module with 1 CO relay (AgSnO)
- PUSH IN and screw connection

### TR T 24 V DC 1CO M3

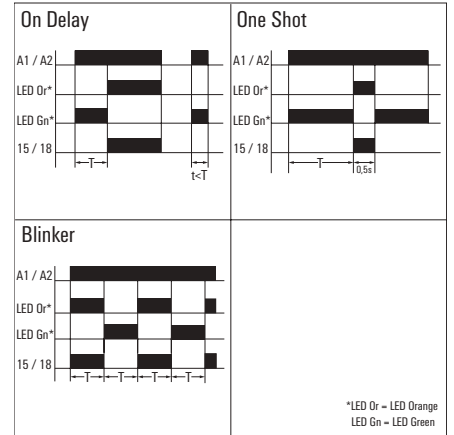
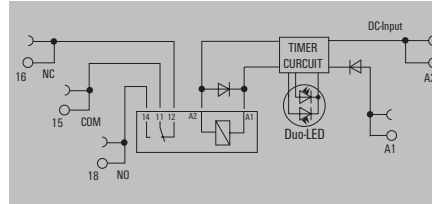
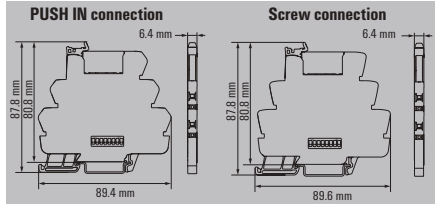

### Technical data

#### Control side

Rated control voltage  
Power rating  
Status indicator

Repeat accuracy  
Basic accuracy  
Setting tolerance  
Min. pulse duration  
Time ranges  
Max. reset time after voltage interruption

#### Load side

Rated switching voltage  
Max. switching voltage, AC  
Max. switching voltage, DC  
Continuous current  
AC switching capacity (resistive), max.  
DC switching capacity (resistive), max.  
Max. switching frequency at rated load  
Contact type  
Mechanical service life

#### General data

Ambient temperature (operational)  
Storage temperature  
Humidity  
Version  
Resistance to vibration EN 61812-1  
Approvals

#### Insulation coordinates

Rated voltage  
Clearance and creepage distances for control side - load side  
Dielectric strength for control side - load side  
Impulse withstand voltage  
Protection degree

#### Dimensions

Clamping range (nominal / min. / max.) mm<sup>2</sup>  
Depth x width x height mm

#### Note

24 V DC ± 20 %  
280 mW  
Duo-LED orange: relay output on, Green duo-LED lit: supply voltage on, Green duo-LED flashes: incorrect configuration, no function

± 1 %  
≤ 5% (of scale-end value)  
5 %  
50 ms  
0.01 s - 0.1 s, 0.1 s - 1 s, 1 s - 10 s, 10 s - 100 s  
50

250 V AC  
250 V  
250 V  
6 A  
1500 VA  
144 W @ 24 V  
0.1 Hz  
1 CO contact (AgSnO)  
5 x 10<sup>6</sup> switching cycles

-20 °C...60 °C  
-40 °C...85 °C  
5-95% relative humidity, T<sub>v</sub> = 40 °C, without condensation

CE; cULus; DETNORVER; UKCA

250 V  
≥ 6 mm  
4 kV<sub>eff</sub> / 1 Min.  
6 kV (1.2/50 μs)  
IP20

	PUSH IN connection	Screw connection
Clamping range	1.5 / 0.14 / 2.5	1.5 / 0.14 / 2.5
Depth x width x height	87.8 / 6.4 / 89.4	87.8 / 6.4 / 89.6

### Ordering data

Screw connection  
PUSH IN connection

Type	Qty.	Order No.
TRS T 24VDC 1CO M3	10	2639560000
TRP T 24VDC 1CO M3	10	2639730000

#### Note

Further approvals and technical data can be found at [eshop.weidmueller.com](http://eshop.weidmueller.com)

### Accessories

#### Note

Accessories: refer to the TERMSERIES Accessories page.

### DC load breaking capacity Resistive load

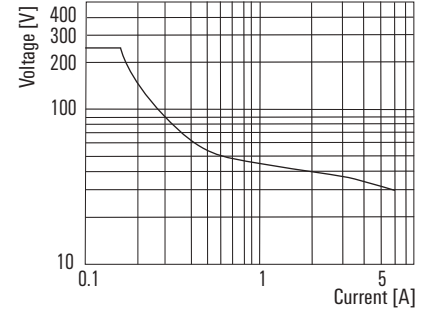

### Electrical endurance 250 V AC resistive load

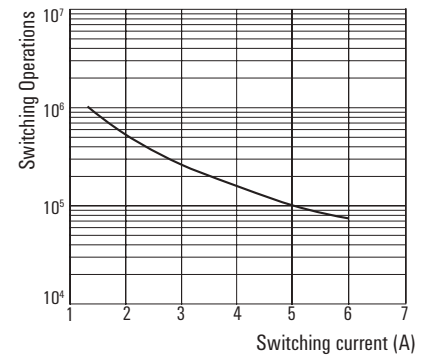

**Empty socket**

- Space-saving, 6.4 mm wide
- 3 time functions
- Empty sockets for electromechanical relays and solid-state relays
- PUSH IN and screw connection

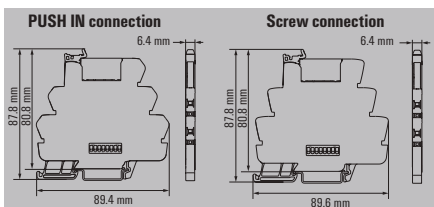

**TR T 24 V DC 1CO M3 EMPTY**

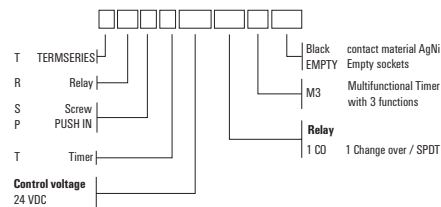
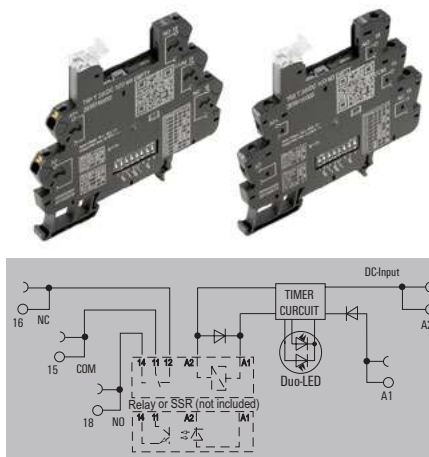

**Technical data**

Control side	
Rated control voltage	24 V DC ± 20 %
Power rating	
Status indicator	Duo-LED orange: relay output on, Green duo-LED lit: supply voltage on, Green duo-LED flashes: incorrect configuration, no function
Repeat accuracy	± 1 %
Basic accuracy	≤ 5 % (of scale-end value)
Setting tolerance	5 %
Min. pulse duration	50 ms
Time ranges	0.01 s - 0.1 s, 0.1 s - 1 s, 1 s - 10 s, 10 s - 100 s
Max. reset time after voltage interruption	50
Load side	
Rated switching voltage	250 V AC
Max. switching voltage, AC	250 V
Max. switching voltage, DC	250 V
Continuous current	10 A
General data	
Ambient temperature (operational)	-20 °C...60 °C
Storage temperature	-40 °C...85 °C
Humidity	5-95% relative humidity, T <sub>a</sub> = 40°C, without condensation
Version	Empty socket
Resistance to vibration EN 61812-1	
Approvals	CE; cURus; DETNORVER; UKCA
Insulation coordinates	
Rated voltage	250 V
Clearance and creepage distances for control side - load side	≥ 6 mm
Dielectric strength for control side - load side	4 kV <sub>eff</sub> / 1 Min.
Impulse withstand voltage	6 kV (1.2/50 µs)
Protection degree	IP20
Dimensions	
Clamping range (nominal / min. / max.)	mm <sup>2</sup>
Depth x width x height	mm
Note	

	PUSH IN connection	Screw connection
Clamping range (nominal / min. / max.)	1.5 / 0.14 / 2.5	1.5 / 0.14 / 2.5
Depth x width x height	87.8 / 6.4 / 89.4	87.8 / 6.4 / 89.6

**Ordering data**

Type	Qty.	Order No.
TRS T 24VDC 1CO M3 EMPTY	10	2639720000
TRP T 24VDC 1CO M3 EMPTY	10	2639740000

Further approvals and technical data can be found at [eshop.weidmueller.com](http://eshop.weidmueller.com)

**Accessories**

Note: Accessories: refer to the TERMSERIES Accessories page.

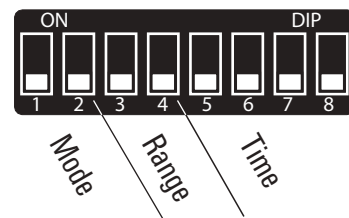

■ = On (DIP-switch turned to ON-position)

Mode	1	2
On Delay	■	■
One Shot	■	
Blinker		■

Range	3	4
10-100s	■	■
1-10s	■	
0.1-1s		■
10-100ms		

Time	5	6	7	8
0.1				
0.2				■
0.3			■	
0.4			■	■
0.5		■		
0.6		■	■	
0.7		■	■	
0.8		■	■	■
0.9	■			
1.0	■			■

## TFI-SERIES

### Compact timing relays for building and factory automation

#### C

Timing relays fulfil many functions in industrial environments. In automation technology, they are used to compensate for errors caused by excessive cycle rates. Among other things, short pulses are extended so that they can be reliably detected by downstream control components.

Our TFI-SERIES consists of five different devices covering the most important applications in building and factory automation. Four of these carry out individual functions: clock generator (pause and pulse start), star-delta switch, on-delay and off-delay with control input. There is also a multifunctional version with seven different timing functions. The timing functions and time ranges can be easily configured using a rotary switch fitted on the front. All of the devices meet the international standards according to EN 61812 and have UL approval for the North American market.

#### Your special advantages:

- Recessed setting potentiometers and status indication via LED
- Suitable for control voltages from 12/24 - 240 V UC and ambient temperatures from -25 °C to +60 °C
- Available in installation design and compact industrial design
- CE-compliant and UL-certified for international use



**Efficient PUSH IN connection technology**

Due to PUSH IN connection technology, the wiring time during installation is significantly reduced. The coloured pushers prevent incorrect wiring.

**Installation design**

**Compliance with international standards according to EN 61812**

The design and function of the devices comply with the international standard for timing relays according to EN 61812.

**Compact industrial design**

**C**



**UL approval for the North American market**

All timing relays have a cULus listing and can therefore be used on the North American market without any problems.

**Simple configuration via rotary switch**

Timing functions and time ranges are configured by means of a rotary switch on the front of the devices.

Timing functions – TFI-SERIES

TFI-SERIES

- Multi-voltage input: 12...240 V AC/DC
- Space-saving design
- 7 time functions with separate control input
- cULus approval

TFIS 12-240VUC 1C0 M7C

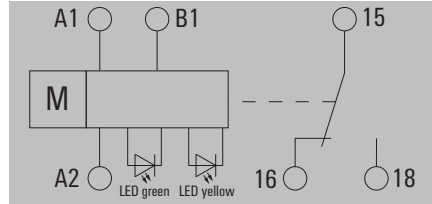
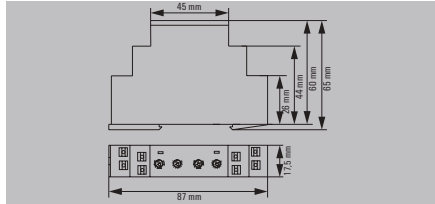

Technical data

Control side

Rated control voltage	12...240 V UC -10 % / +10 %
Power rating	4 VA, 1.5 W
Status indicator	LED green (U/t): flashes when time runs, lights permanently with supply voltage applied, LED yellow (R): relay closed
Repeat accuracy	<0.5 % or ±5 ms
Basic accuracy	±6% (of scale-end value, for time range 0.05 s - 1 s), ±1% (of scale-end value, for all other time ranges)
Setting tolerance	5 %
Min. pulse duration	100 ms
Time ranges	0.05 s - 1 s, 0.5 s - 10 s, 3 s - 60 s, 30 s - 10 min, 3 min - 1 h, 30 min - 10 h, 5 h - 100 h

Load side

Rated switching voltage	250 V AC
Max. switching voltage, AC	250
Max. switching voltage, DC	30 V
Continuous current	8 A
AC switching capacity (resistive), max.	2000 VA
DC switching capacity (resistive), max.	240 W
Max. switching frequency at rated load	
Contact material	AgNi
Mechanical service life	20 x 10 <sup>6</sup> switching cycles

General data

Ambient temperature (operational)	-25 °C...55 °C
Storage temperature	-25 °C...70 °C
Humidity	15...85 % rel. humidity, no condensation
Version	with separate control input
Resistance to vibration EN 61812-1	10 Hz...60 Hz: 0.15 mm, 60 Hz...150 Hz: 2 g
Approvals	CE; cULus

Insulation coordinates

Rated voltage	300 V
Clearance and creepage distances for control side - load side	≥ 3 mm
Dielectric strength for control side - load side	1.6 kV
Impulse withstand voltage	4 kV
Protection degree	IP20

Dimensions

Clamping range (nominal / min. / max.)	mm <sup>2</sup>
Depth x width x height	mm

Note

Ordering data

Screw connection	
PUSH IN connection	

Note

Accessories

Note

12...240 V UC -10 % / +10 %

4 VA, 1.5 W
LED green (U/t): flashes when time runs, lights permanently with supply voltage applied, LED yellow (R): relay closed
<0.5 % or ±5 ms
±6% (of scale-end value, for time range 0.05 s - 1 s), ±1% (of scale-end value, for all other time ranges)
5 %
100 ms
0.05 s - 1 s, 0.5 s - 10 s, 3 s - 60 s, 30 s - 10 min, 3 min - 1 h, 30 min - 10 h, 5 h - 100 h

250 V AC

250
30 V
8 A
2000 VA
240 W
AgNi
20 x 10 <sup>6</sup> switching cycles

-25 °C...55 °C

-25 °C...70 °C
15...85 % rel. humidity, no condensation
with separate control input
10 Hz...60 Hz: 0.15 mm, 60 Hz...150 Hz: 2 g
CE; cULus

300 V

≥ 3 mm
1.6 kV
4 kV
IP20

Screw connection PUSH IN connection

2.5 / 0.5 / 4	2.5 / 0.2 / 2.5
60 / 17.5 / 87	60 / 17.5 / 87

Type Qty. Order No.

TFIS 12-240VUC 1C0 M7C	1	2697250000
TFIP 12-240VUC 1C0 M7C	1	2898320000

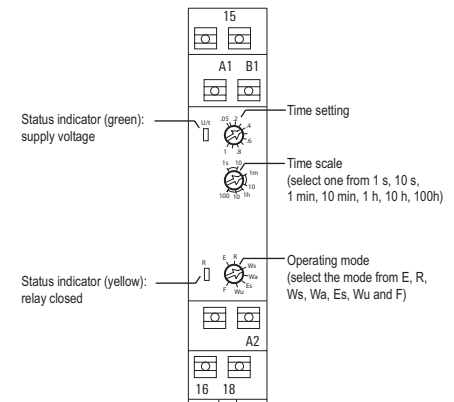
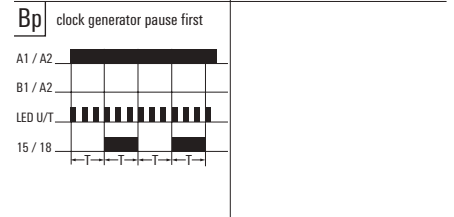
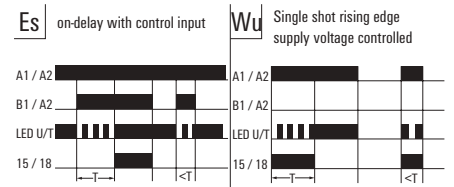
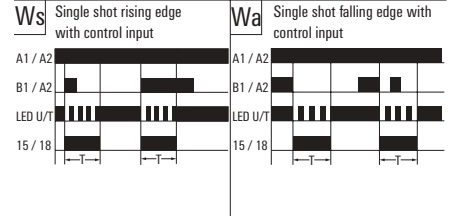
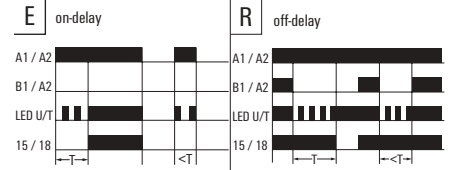

**TFI-SERIES**

- Multi-voltage input: 12...240 V AC/DC
- Space-saving design
- Clock generator with separate control input
- cULus approval

**TFIS 12-240VUC 1CO CG**

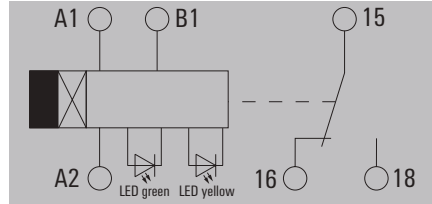
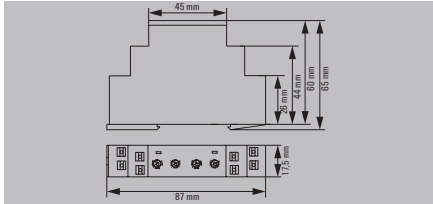

**Ip** clock generator pause first

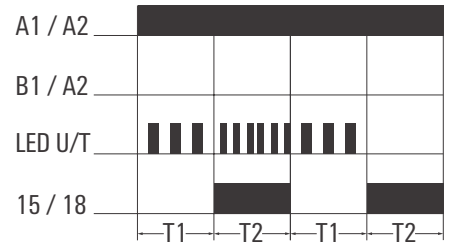

**li** clock generator pulse first

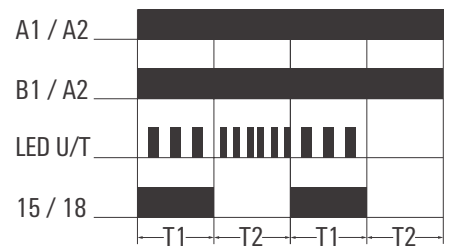

Function li with fixed jumper A1-B1

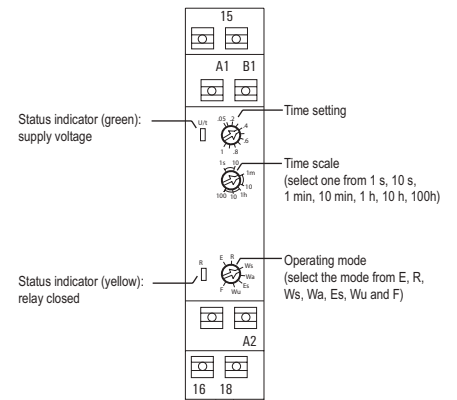

**Technical data**

**Control side**

Rated control voltage  
Power rating  
Status indicator

Repeat accuracy  
Basic accuracy

Setting tolerance  
Min. pulse duration  
Time ranges

**Load side**

Rated switching voltage  
Max. switching voltage, AC  
Max. switching voltage, DC  
Continuous current  
AC switching capacity (resistive), max.  
DC switching capacity (resistive), max.  
Max. switching frequency at rated load  
Contact material  
Mechanical service life

**General data**

Ambient temperature (operational)  
Storage temperature  
Humidity  
Version  
Resistance to vibration EN 61812-1  
Approvals

**Insulation coordinates**

Rated voltage  
Clearance and creepage distances for control side - load side  
Dielectric strength for control side - load side  
Impulse withstand voltage

**Dimensions**

Clamping range (nominal / min. / max.) mm<sup>2</sup>  
Depth x width x height mm

**Note**

12...240 V UC -10 % / +10 %  
4 VA, 1.5 W  
LED green (U/T): flashes slowly when time t1 runs, flashes quickly when time t2 runs, lights permanently when supply voltage is applied, LED yellow (R): relay closed  
<0.5 % or ±5 ms  
±6% (of scale-end value, for time range 0.05 s - 1 s), ±1% (of scale-end value, for all other time ranges)  
5 %  
100 ms  
0.05 s - 1 s, 0.5 s - 10 s, 3 s - 60 s, 30 s - 10 min, 3 min - 1 h, 30 min - 10 h, 5 h - 100 h

250 V AC  
250  
30 V  
8 A  
2000 VA  
240 W

AgNi  
20 x 10<sup>6</sup> switching cycles

-25 °C...55 °C  
-25 °C...70 °C  
15...85 % rel. humidity, no condensation

10 Hz...60 Hz: 0.15 mm, 60 Hz...150 Hz: 2 g  
CE: cULus

300 V  
≥ 3 mm  
1.6 kV  
4 kV

Screw connection	PUSH IN connection
2.5 / 0.5 / 4	2.5 / 0.2 / 2.5
60 / 17.5 / 87	60 / 17.5 / 87

**Ordering data**

Screw connection  
PUSH IN connection

Type	Qty.	Order No.
TFIS 12-240VUC 1CO CG	1	2697260000
TFIP 12-240VUC 1CO CG	1	2898310000

**Note**

**Accessories**

**Note**

## Timing functions – TFI-SERIES

### TFI-SERIES

- Multi-voltage input: 24...240 V AC/DC
- Space-saving design
- Switch-on delayed
- cULus approval

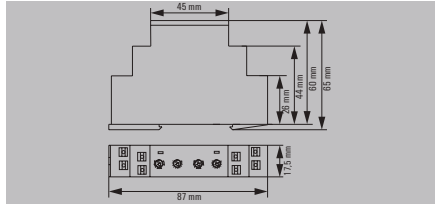

### TFIS 24-240VUC 1CO ON

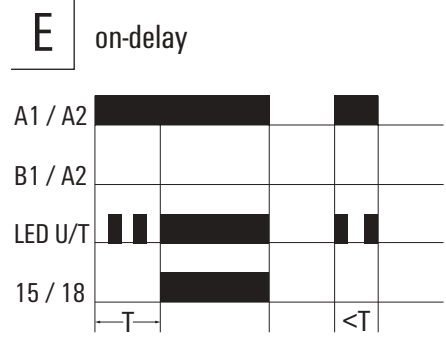
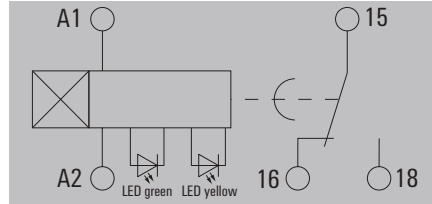

### Technical data

Control side	
Rated control voltage	24...240 V UC - 15 % / + 10 %
Power rating	4 VA, 1.5 W
Status indicator	LED green (U/t): flashes when time runs, lights permanently with supply voltage applied, LED yellow (R): relay closed
Repeat accuracy	<0.5 % or ±5 ms
Basic accuracy	±6% (of scale-end value, for time range 0.05 s - 1 s), ±1% (of scale-end value, for all other time ranges)
Setting tolerance	5 %
Min. pulse duration	100 ms
Time ranges	0.05 s - 1 s, 0.5 s - 10 s, 3 s - 60 s, 30 s - 10 min, 3 min - 1 h, 30 min - 10 h, 5 h - 100 h
Load side	
Rated switching voltage	250 V AC
Max. switching voltage, AC	250
Max. switching voltage, DC	30 V
Continuous current	8 A
AC switching capacity (resistive), max.	2000 VA
DC switching capacity (resistive), max.	240 W
Max. switching frequency at rated load	
Contact material	AgNi
Mechanical service life	20 x 10 <sup>6</sup> switching cycles
General data	
Ambient temperature (operational)	-25 °C...55 °C
Storage temperature	-25 °C...70 °C
Humidity	15...85 rel. humidity, no condensation
Version	
Resistance to vibration EN 61812-1	10 Hz...60 Hz: 0.15 mm, 60 Hz...150 Hz: 2 g
Approvals	CE: cULus
Insulation coordinates	
Rated voltage	300 V
Clearance and creepage distances for control side - load side	≥ 3 mm
Dielectric strength for control side - load side	1.6 kV
Impulse withstand voltage	4 kV
Dimensions	
Clamping range (nominal / min. / max.)	mm <sup>2</sup>
Depth x width x height	mm
Note	
Screw connection	PUSH IN connection
2.5 / 0.5 / 4	2.5 / 0.2 / 2.5
60 / 17.5 / 87	60 / 17.5 / 87

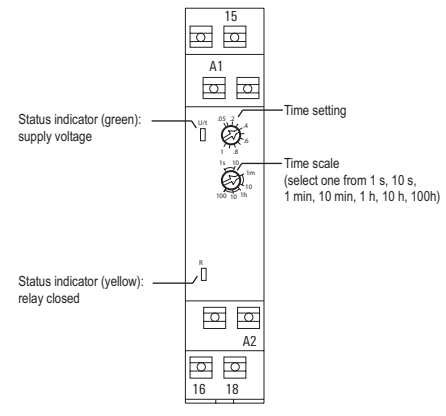

### Ordering data

Type	Qty.	Order No.
TFIS 24-240VUC 1CO ON	1	2697280000
TFIP 24-240VUC 1CO ON	1	2898340000

Note

### Accessories

Note

**TFI-SERIES**

- Multi-voltage input: 24...240 V AC/DC
- Space-saving design
- Delayed-back with separate control input
- cULus approval

**TFIS 24-240VUC 1CO OFFC**

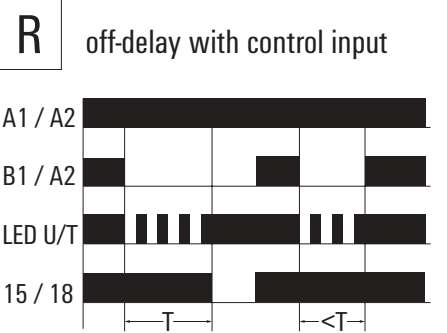
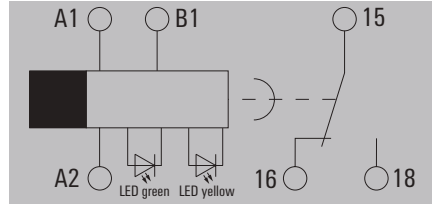
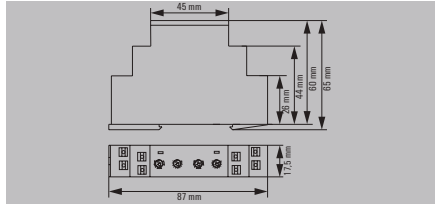

**Technical data**

**Control side**

Rated control voltage	24...240 V UC - 15 % / + 10 %
Power rating	4 VA, 1.5 W
Status indicator	LED green (U/T): flashes when time runs, lights permanently with supply voltage applied, LED yellow (R): relay closed
Repeat accuracy	<0.5 % or ±5 ms
Basic accuracy	±6% (of scale-end value, for time range 0.05 s - 1 s), ±1% (of scale-end value, for all other time ranges)
Setting tolerance	5 %
Min. pulse duration	100 ms
Time ranges	0.05 s - 1 s, 0.5 s - 10 s, 3 s - 60 s, 30 s - 10 min, 3 min - 1 h, 30 min - 10 h, 5 h - 100 h

**Load side**

Rated switching voltage	250 V AC
Max. switching voltage, AC	250
Max. switching voltage, DC	30 V
Continuous current	8 A
AC switching capacity (resistive), max.	2000 VA
DC switching capacity (resistive), max.	240 W
Max. switching frequency at rated load	
Contact material	AgNi
Mechanical service life	20 x 10 <sup>6</sup> switching cycles

**General data**

Ambient temperature (operational)	-25 °C...55 °C
Storage temperature	-25 °C...70 °C
Humidity	15...85 % rel. humidity, no condensation
Version	with separate control input
Resistance to vibration EN 61812-1	10 Hz...60 Hz: 0.15 mm, 60 Hz...150 Hz: 2 g
Approvals	CE: cULus

**Insulation coordinates**

Rated voltage	300 V
Clearance and creepage distances for control side - load side	≥ 3 mm
Dielectric strength for control side - load side	1.6 kV
Impulse withstand voltage	4 kV

**Dimensions**

Clamping range (nominal / min. / max.)	mm <sup>2</sup>
Depth x width x height	mm

**Note**

**Ordering data**

	Screw connection
	PUSH IN connection

**Note**

**Accessories**

**Note**

**Technical data**

Rated control voltage	24...240 V UC - 15 % / + 10 %
Power rating	4 VA, 1.5 W
Status indicator	LED green (U/T): flashes when time runs, lights permanently with supply voltage applied, LED yellow (R): relay closed
Repeat accuracy	<0.5 % or ±5 ms
Basic accuracy	±6% (of scale-end value, for time range 0.05 s - 1 s), ±1% (of scale-end value, for all other time ranges)
Setting tolerance	5 %
Min. pulse duration	100 ms
Time ranges	0.05 s - 1 s, 0.5 s - 10 s, 3 s - 60 s, 30 s - 10 min, 3 min - 1 h, 30 min - 10 h, 5 h - 100 h

**Load side**

Rated switching voltage	250 V AC
Max. switching voltage, AC	250
Max. switching voltage, DC	30 V
Continuous current	8 A
AC switching capacity (resistive), max.	2000 VA
DC switching capacity (resistive), max.	240 W
Max. switching frequency at rated load	
Contact material	AgNi
Mechanical service life	20 x 10 <sup>6</sup> switching cycles

**General data**

Ambient temperature (operational)	-25 °C...55 °C
Storage temperature	-25 °C...70 °C
Humidity	15...85 % rel. humidity, no condensation
Version	with separate control input
Resistance to vibration EN 61812-1	10 Hz...60 Hz: 0.15 mm, 60 Hz...150 Hz: 2 g
Approvals	CE: cULus

**Insulation coordinates**

Rated voltage	300 V
Clearance and creepage distances for control side - load side	≥ 3 mm
Dielectric strength for control side - load side	1.6 kV
Impulse withstand voltage	4 kV

**Dimensions**

Clamping range (nominal / min. / max.)	mm <sup>2</sup>
Depth x width x height	mm

**Note**

**Ordering data**

Type	Qty.	Order No.
TFIS 24-240VUC 1CO OFFC	1	2697290000
TFIP 24-240VUC 1CO OFFC	1	2898330000

**Note**

**Accessories**

**Note**

**C**

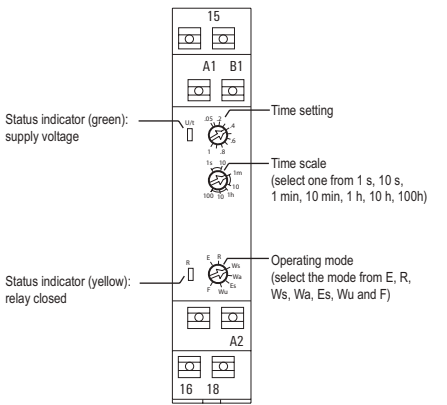

**Timing functions – TFI-SERIES**

**TFI-SERIES**

- Multi-voltage input: 12...240 V AC/DC
- Space-saving design
- Star-delta-startup
- cULus approval

**TFIS 12-240VUC 2NO SD**

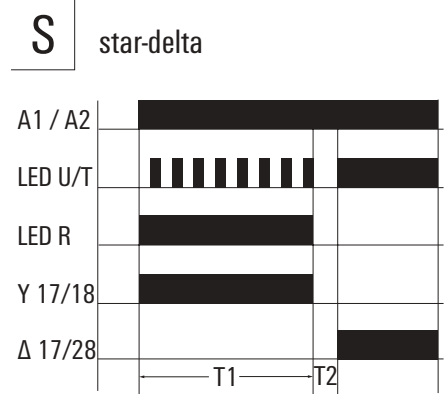
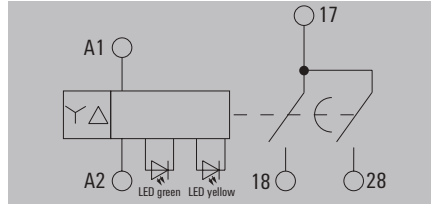
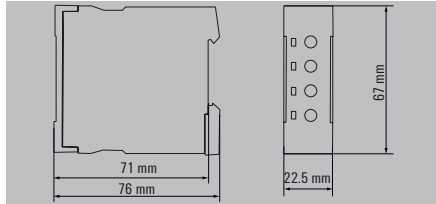

**Technical data**

Control side	
Rated control voltage	12...240 V UC - 10 % / + 10 %
Power rating	500 mVA, 180 mW
Status indicator	LED green (U/t) flashes: star-relay closed, time runs, LED green (U/t) lights permanently: delta-relay closed, time runs, LED yellow (R): star-relay closed
Repeat accuracy	<0.5 % or ±5 ms
Basic accuracy	± 1 % (of scale-end value)
Setting tolerance	5 %
Min. pulse duration	100 ms
Time ranges	0.5 s - 10 s, 1.5 s - 30 s, 3 s - 60 s, 9 s - 180 s
Load side	
Rated switching voltage	250 V AC
Max. switching voltage, AC	250
Max. switching voltage, DC	30 V
Continuous current	3 A
AC switching capacity (resistive), max.	750 VA
DC switching capacity (resistive), max.	90 W
Max. switching frequency at rated load	
Contact material	AgNi
Mechanical service life	20 x 10 <sup>6</sup> switching cycles
General data	
Ambient temperature (operational)	-25 °C...60 °C
Storage temperature	-40 °C...70 °C
Humidity	5...95 % rel. humidity, no condensation
Version	
Resistance to vibration EN 61812-1	10 Hz...60 Hz: 0.15 mm, 60 Hz...150 Hz: 2 g
Approvals	CE, cULus
Insulation coordinates	
Rated voltage	300 V
Clearance and creepage distances for control side - load side	≥ 3 mm
Dielectric strength for control side - load side	1.6 kV
Impulse withstand voltage	4 kV
Protection degree	IP20
Dimensions	
Clamping range (nominal / min. / max.)	mm <sup>2</sup>
Depth x width x height	mm
75 / 225 / 67	
Screw connection	
2.5 / 0.5 / 4	
75 / 225 / 67	

**Ordering data**

Type	Qty.	Order No.
TFIS 12-240VUC 2NO SD	1	2697270000

**Note**

**Accessories**

**Note**

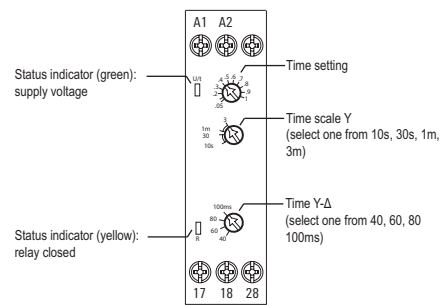



## IT-TIMER

### Compact multi-functional timing relay for easy control signal adjustment

#### C

In automation technology, timing relays are used to prevent malfunctions due to high pulse times. Among other things, short pulses are extended in order to be reliably detected by subsequent control modules. Various timing functions, such as on-delay, off-delay and clock generator, are available.

With IT-TIMER, Weidmüller's range includes a highly efficient timing relay with multi-voltage input that combines a range of functions with a compact size. It is particularly easy to configure the timing functions thanks to the flat front cover, the easy-to-read LED status indicator and operation with standard tools. IT-TIMER meets the requirements of IEC 61812-1. It is designed for an operating range from 24 V DC to 48 V DC or 24 V AC to 240 V AC and can therefore be used in a wide variety of applications.

#### Your special advantages:

- High level of functionality in a compact size
- Timing functions that are easy to configure using standard tools
- Can be used internationally thanks to compliance with EN 61812-1
- Seven timing functions for a wide range of applications make the IT-TIMER a smart solution for your application



**Multi-voltage input**

The timing relay operates from 24 V DC up to 48 V DC and from 24 V AC up to 240 V AC. It can therefore be used in a wide range of applications.

**Global standard**

International usage is guaranteed in accordance with the standard IEC 61812-1.

**IEC**  
61812-1

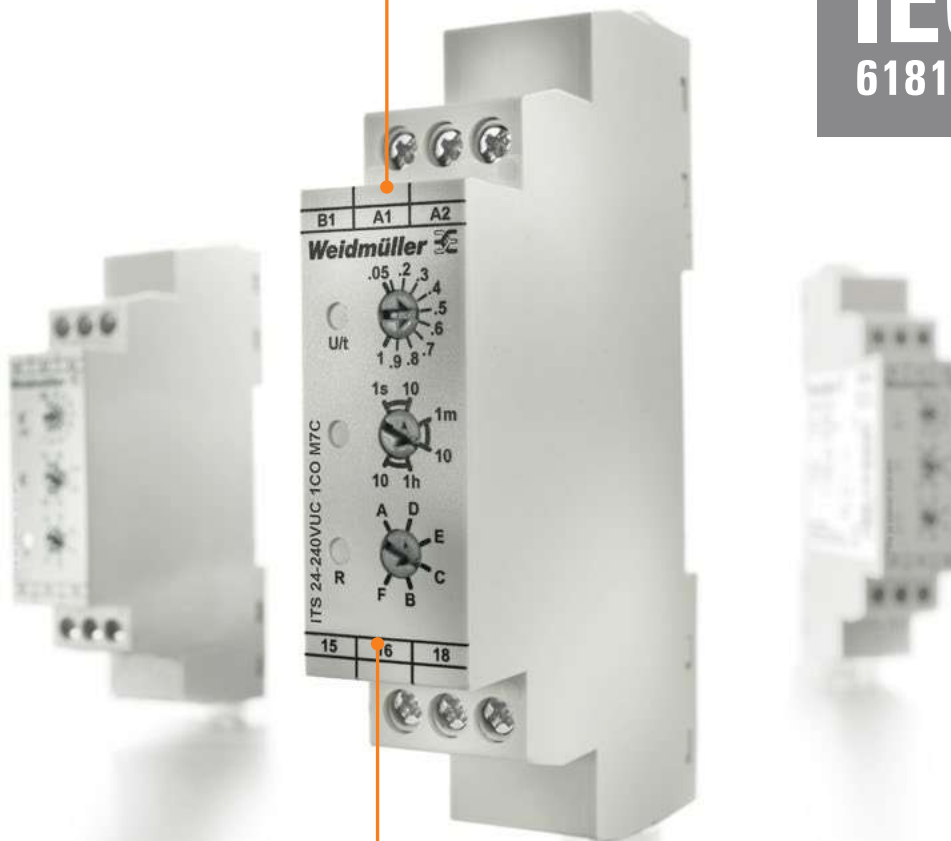
**Seven timing functions**

Due to its multi-functional concept, the IT-TIMER covers a broad range of typically needed timing functions.

Timing functions – IT-TIMER

Timing relay

- Multi-voltage input: 24 - 48 V DC, 24 - 240 V AC
- Space-saving construction
- 7 time functions with separate control input

ITS 24-240 V UC 1 CO M7C

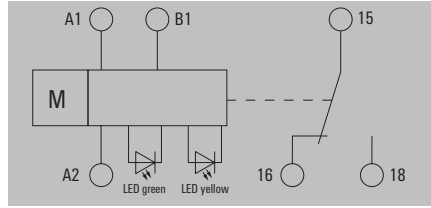
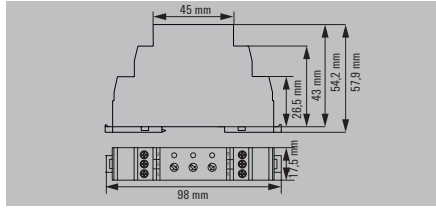

Technical data

Control side	
Rated control voltage	24..48 V DC - 15 % / + 10 % / 24..240 V AC - 15 % / + 10 %
Power rating	8 VA @ 230 V AC, 0.4 W at 24 V DC
Status indicator	LED green (U/t): flashes when time runs, lights permanently with supply voltage applied, LED yellow (R): relay closed
Repeat accuracy	<0.5 % or ±5 ms
Basic accuracy	±6% (of scale-end value, for time range 0.05 s - 1 s), ±1.5% (of scale-end value, for all other time ranges)
Setting tolerance	5 %
Min. pulse duration	50 ms
Time ranges	0.05 s - 1 s, 0.5 s - 10 s, 3 s - 60 s, 0.5 min - 10 min, 3 min - 1 h, 0.5 h - 10 h
Max. reset time after voltage interruption	100
Load side	
Rated switching voltage	250 V AC
Max. switching voltage, AC	250
Max. switching voltage, DC	30 V
Continuous current	5 A
AC switching capacity (resistive), max.	1250 VA
DC switching capacity (resistive), max.	90 W
Max. switching frequency at rated load	
Contact material	AgNi
Mechanical service life	1 x 10 <sup>6</sup> switching cycles
General data	
Ambient temperature (operational)	-25 °C...50 °C
Storage temperature	-40 °C...70 °C
Humidity	25 - 75%, no condensation
Version	with separate control input
Resistance to vibration EN 61812-1	10 Hz...60 Hz: 0.15 mm, 60 Hz...150 Hz: 2 g
Approvals	CE, UKCA
Insulation coordinates	
Rated voltage	300 V
Clearance and creepage distances for control side - load side	≥ 3 mm
Dielectric strength for control side - load side	1.6 kV
Impulse withstand voltage	2.5 kV
Dimensions	
Clamping range (nominal / min. / max.)	2.5 / 0.25 / 2.5 mm <sup>2</sup>
Depth x width x height	57.9 / 17.5 / 98 mm
Note	

Type	Qty.	Order No.
ITS 24-240VUC 1CO M7C	1	2496190000
ITS 24-240VUC M7C PU10	10	2545120000

Ordering data

	Screw connection
	Screw connection

Note

Accessories

Note
------

Time functions

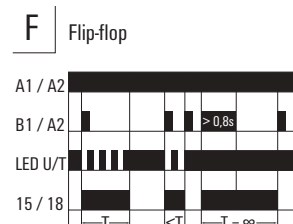
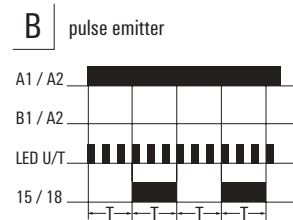
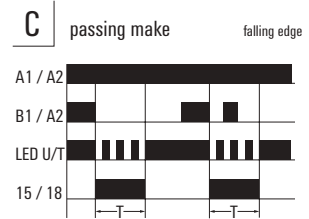
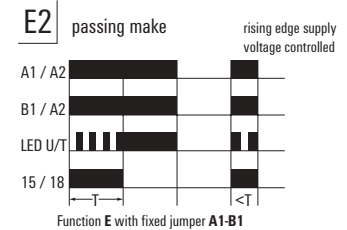
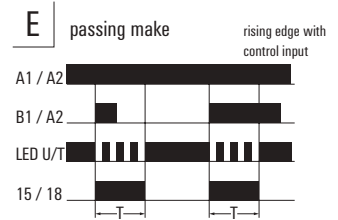
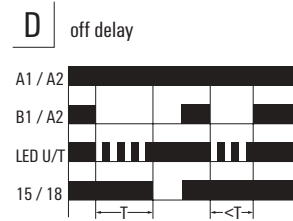
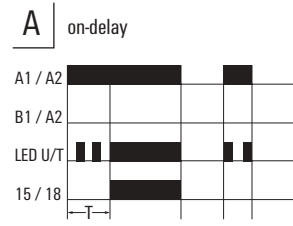



## MCZ TO

### The narrow pulse stretcher measuring just 6.1 mm wide

**C** Pulse stretchers are used in automation technology to extend very short input pulses of less than 10 ms. Such short pulses are generated by light barriers, for example, and cannot be processed by conventional timing relays. The extended pulses, on the other hand, can be forwarded directly to the PLC.

MCZ TO is one of the narrowest pulse stretchers on the market. It extends even very short pulses  $\geq 3.5$  ms and has a fixed switch-off delay (50 ms or 150 ms). MCZ TO operates with low input power, and auxiliary voltages in the input and output are not required. It also includes a watchdog function with restarting of the off-delay. Precisely fitting accessories such as cross-connectors, markers and end plates make it flexible to use.

#### Your special advantages:

- Detection of very short input pulses ( $\geq 3.5$  ms)
- Versatile to use thanks to three cross-connector connections
- Proven and reliable tension clamp connection system
- High level of safety thanks to integrated reverse polarity protection



 No auxiliary voltage is required

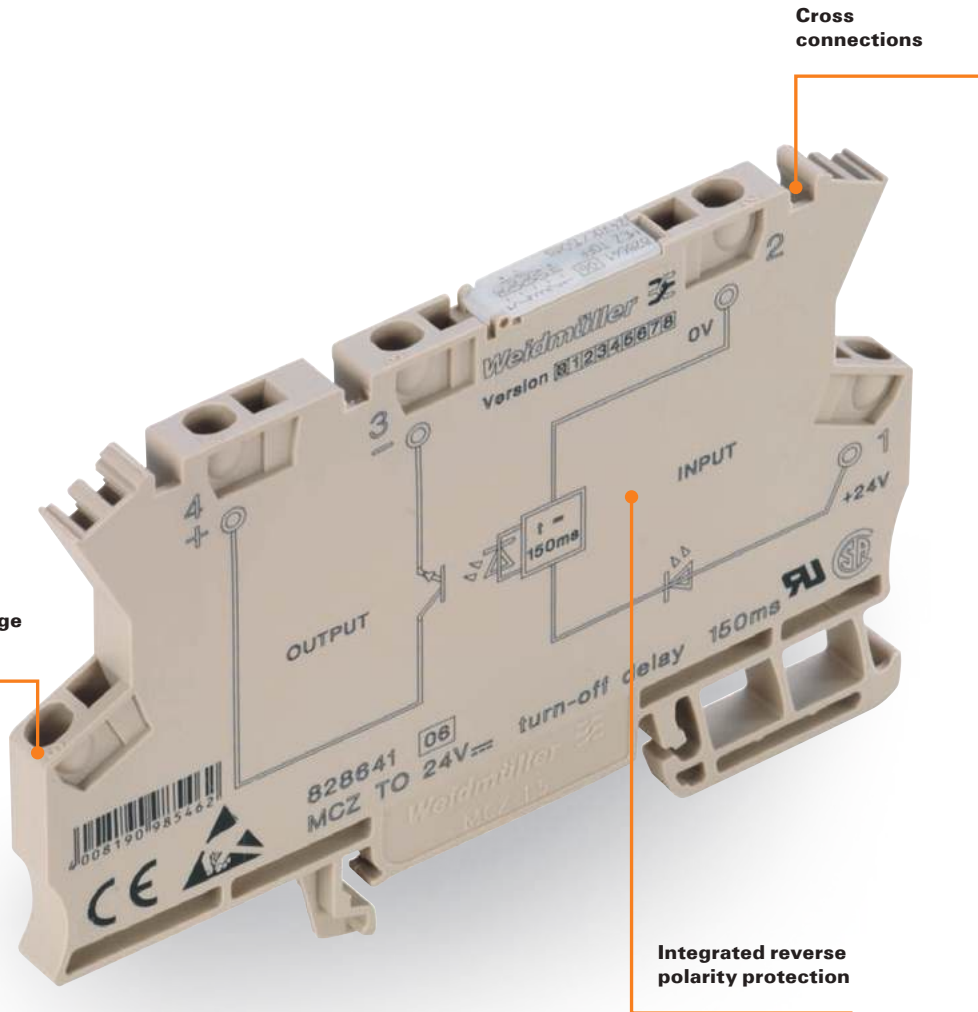

**Timing functions – MCZ SERIES**

**MCZ TO**

- Components for lengthening short pulses for the PLC
- Fixed switch-off delay
- Low input power
- Screwless
- Tension clamp connection
- Width 6 mm
- For mounting on TS 35

**24 V DC 50 ms**

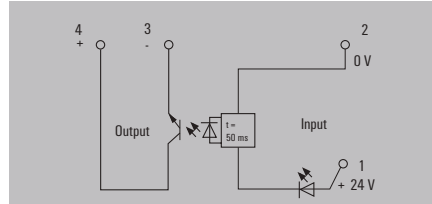

**24 V DC 150 ms**

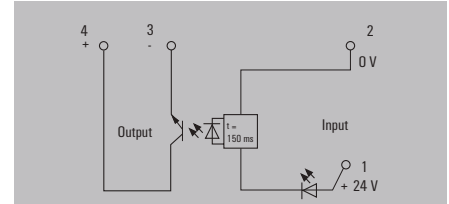

**Technical data**

Control side	
Rated control voltage	24 V DC ±10 %
Rated current AC / DC	/ 6.7 mA ±10 %
Power rating	160 mW
Min. pulse duration	2 ms
Status indicator	Green LED
Load side	
Rated switching voltage	5...48 V DC
Continuous current	20 mA
Switch-off delay	50 ms
Max. switching frequency at rated load	5 Hz
Rated data	
Ambient temperature (operational)	-25 °C...50
Storage temperature	-40 °C...85 °C
Humidity	40 °C / 93 % rel. humidity, no condensation
Approvals	CE, CSA, cURus, UKCA
Insulation coordinates	
Rated voltage	300 V
Overvoltage category	IV
Dielectric strength for control side - load side	1 kV <sub>eff</sub> / 1 s
Dielectric strength to mounting rail	4 kV <sub>eff</sub> / 1 Min.
Clearance and creepage distances for control side - load side	≥ 5.5 mm
Impulse withstand voltage	6 kV (1.2/50 µs)
Pollution degree	2

Control side	
Rated control voltage	24 V DC ±10 %
Rated current AC / DC	/ 6.7 mA ±10 %
Power rating	160 mW
Min. pulse duration	2 ms
Status indicator	Green LED
Load side	
Rated switching voltage	5...48 V DC
Continuous current	20 mA
Switch-off delay	150 ms
Max. switching frequency at rated load	3 Hz
Rated data	
Ambient temperature (operational)	-25 °C...50
Storage temperature	-40 °C...85 °C
Humidity	40 °C / 93 % rel. humidity, no condensation
Approvals	CE, CSA, cURus, UKCA
Insulation coordinates	
Rated voltage	300 V
Overvoltage category	IV
Dielectric strength for control side - load side	1 kV <sub>eff</sub> / 1 s
Dielectric strength to mounting rail	4 kV <sub>eff</sub> / 1 Min.
Clearance and creepage distances for control side - load side	≥ 5.5 mm
Impulse withstand voltage	6 kV (1.2/50 µs)
Pollution degree	2

Control side	
Rated control voltage	24 V DC ±10 %
Rated current AC / DC	/ 6.7 mA ±10 %
Power rating	160 mW
Min. pulse duration	3.5 ms
Status indicator	Green LED
Load side	
Rated switching voltage	5...48 V DC
Continuous current	20 mA
Switch-off delay	150 ms
Max. switching frequency at rated load	3 Hz
Rated data	
Ambient temperature (operational)	-25 °C...50
Storage temperature	-40 °C...85 °C
Humidity	40 °C / 93 % rel. humidity, no condensation
Approvals	CE, CSA, cURus, UKCA
Insulation coordinates	
Rated voltage	300 V
Overvoltage category	IV
Dielectric strength for control side - load side	1 kV <sub>eff</sub> / 1 s
Dielectric strength to mounting rail	4 kV <sub>eff</sub> / 1 Min.
Clearance and creepage distances for control side - load side	≥ 5.5 mm
Impulse withstand voltage	6 kV (1.2/50 µs)
Pollution degree	2

Dimensions	
Clamping range (nominal / min. / max.)	mm <sup>2</sup> 1.5 / 0.5 / 1.5
Depth x width x height	mm 63.2 / 6.1 / 91
Note	
For mounting on TS 35 rail	

Dimensions	
Clamping range (nominal / min. / max.)	mm <sup>2</sup> 1.5 / 0.5 / 1.5
Depth x width x height	mm 63.2 / 6.1 / 91
Note	
For mounting on TS 35 rail	

Dimensions	
Clamping range (nominal / min. / max.)	mm <sup>2</sup> 1.5 / 0.5 / 1.5
Depth x width x height	mm 63.2 / 6.1 / 91
Note	
For mounting on TS 35 rail	

**Ordering data**

Tension clamp connection	
Note	

Type	Qty.	Order No.
MCZ TO 24VDC/50MS	10	8324590000
Note		

Type	Qty.	Order No.
MCZ TO 24VDC/150MS	10	8286410000
Note		

**Accessories**

Note	
------	--

AP MCZ end plate 8389030000
-----------------------------

AP MCZ end plate 8389030000
-----------------------------



# Functional safety

## Relays for processing safety-related signals

### C

Industrial safety has become an important focus topic. There is an increasing demand for safety systems. At the same time, the demands placed on such systems are increasing. In order to provide optimum protection for plant, users, goods and the environment, dangers and incidents of all kinds should be avoided. This is also evident from the increasingly strict international standards and directives.

We have specially-developed safety relays for processing safety-related signals in our product range. They achieve a safety integrity level of up to SIL3 in accordance with EN 61508 and can therefore be used flexibly in the process industry.

#### **Relay modules with positively-driven contacts**

Relay modules with positively-driven contacts are used in safety-related applications to provide reliable feedback on the switching state of the operating contact to the control system. They enable safe diagnosis via a positively-driven NC contact and ensure the reliable exchange of signals between two systems with feedback function. In elementary relays with positively-driven contacts, NO and NC contacts are mechanically connected to each other. This means that NO and NC contacts can never be closed at the same time, so that a diagnostic coverage of 99% is achieved.

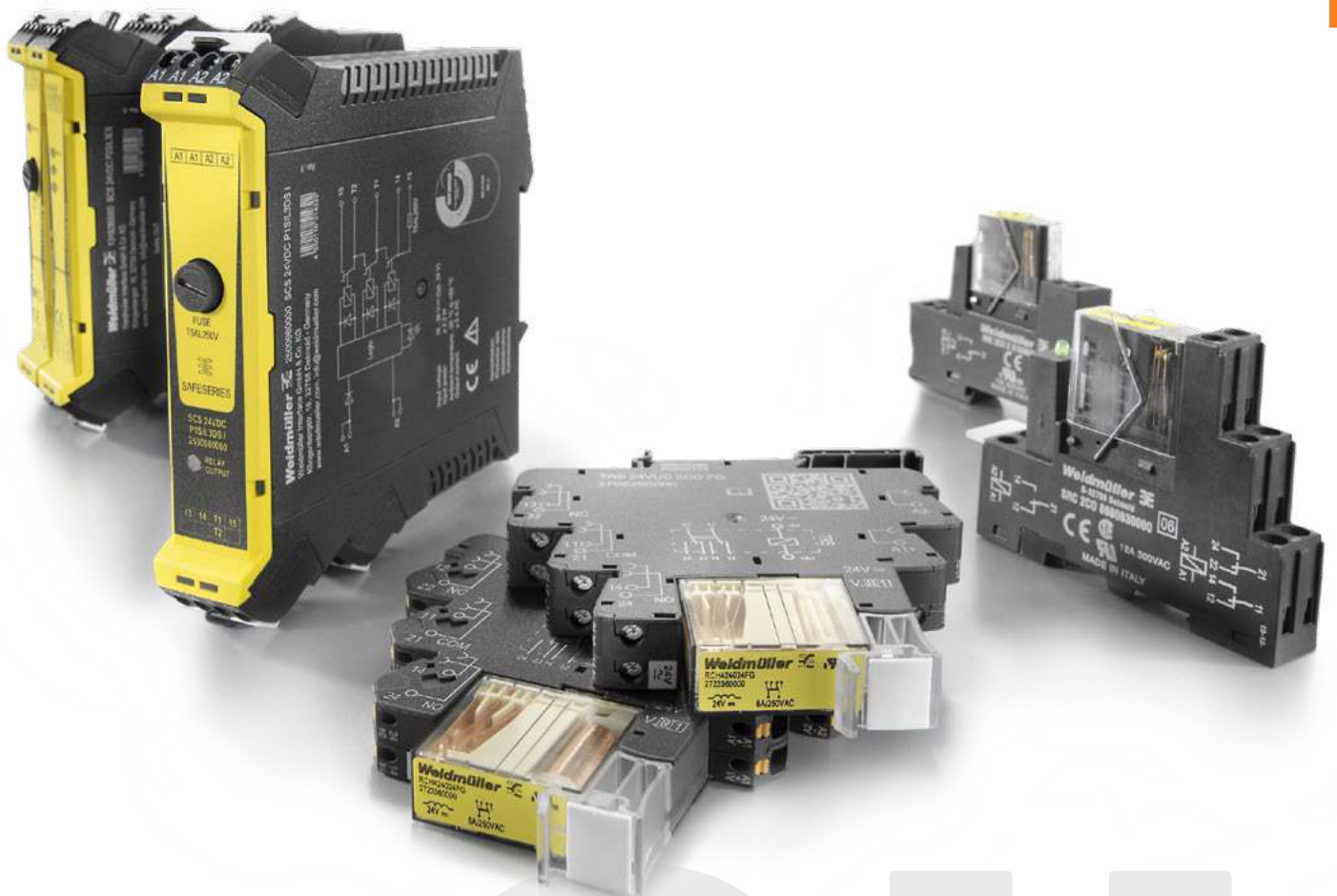

W E I D M Ü L L E R

Visit our website for more information  
[www.weidmueller.com/fs](http://www.weidmueller.com/fs)

## SAFESERIES SIL relays

### Functional safety for process applications

**C** Whether for a burner control system, secure emergency shut down or, for example, for pump controllers – our safety relay guarantees safe conditions and convince with superior and significant features.

Their integration into distributed control systems (DCSs) is even better, with an input filter which makes the SIL circuit immune to the test impulse which is typically used by a DCS. You will also benefit from simple maintenance: the fuses are accessible from the outside and can easily be changed. You can see the status of the safety and the monitoring devices clearly with status LED on the device.

All devices are accredited though certification by the internationally recognised TÜV-NORD group – for secure process applications around the globe.

**Safe control of back-up systems**

Equipped with wide range input voltages in the monitoring circuit from 24 V AC/DC to 230 V AC/DC, the relay is designed for individual use, e.g. in back-up systems or the overfill prevention devices of tank farms.

**Safe activation and deactivation**

This universal device can be used for either the energise-to-safe or de-energise-to-safe operation modes, as you wish. This makes it suitable, e.g. for pump controllers or extinguishing systems.



**Safe monitoring of furnace firing systems**

The feed-in of fuel must be interrupted as soon as a boiler plant reaches any safety criterion limits. The SAFESERIES offers you a safety switch-off for the feed-in of fuel to furnace firing systems up to safety integrity level (SIL) 3.

# You have strict requirements for the functional reliability of your systems

We connect your safety-related applications reliably

## C



Safe process and power technology is a top priority for you. For example, a reliable emergency shutdown, which initiates appropriate countermeasures in hazardous situations, is indispensable. These might extend to the automatic shutdown of the system or subsystems within it.

As a specialist in industrial connectivity, we offer a comprehensive solution for safety-sensitive areas, from the control room through to the field.

The SAFESERIES SIL relay is ideally suited for use in safety-related applications. It is designed for low and high demand modes.

With the wide voltage range input in the monitoring circuit of 24 V UC to 230 V UC, for example, you can control back-up systems with high DC voltage. You get additional flexibility for your applications with the optional "G3" coating for use in harsh environments.

The safe and reliable coupling of measuring instruments, actuators and sub-assemblies to the safety-relevant signal circuit is handled by our VARITECTOR SPC, the lightning and surge protection for signal circuits. Certified for safety requirement level SIL 3 according to EN 61508, and accredited by TÜV NORD, it can easily be incorporated into your safety calculations.

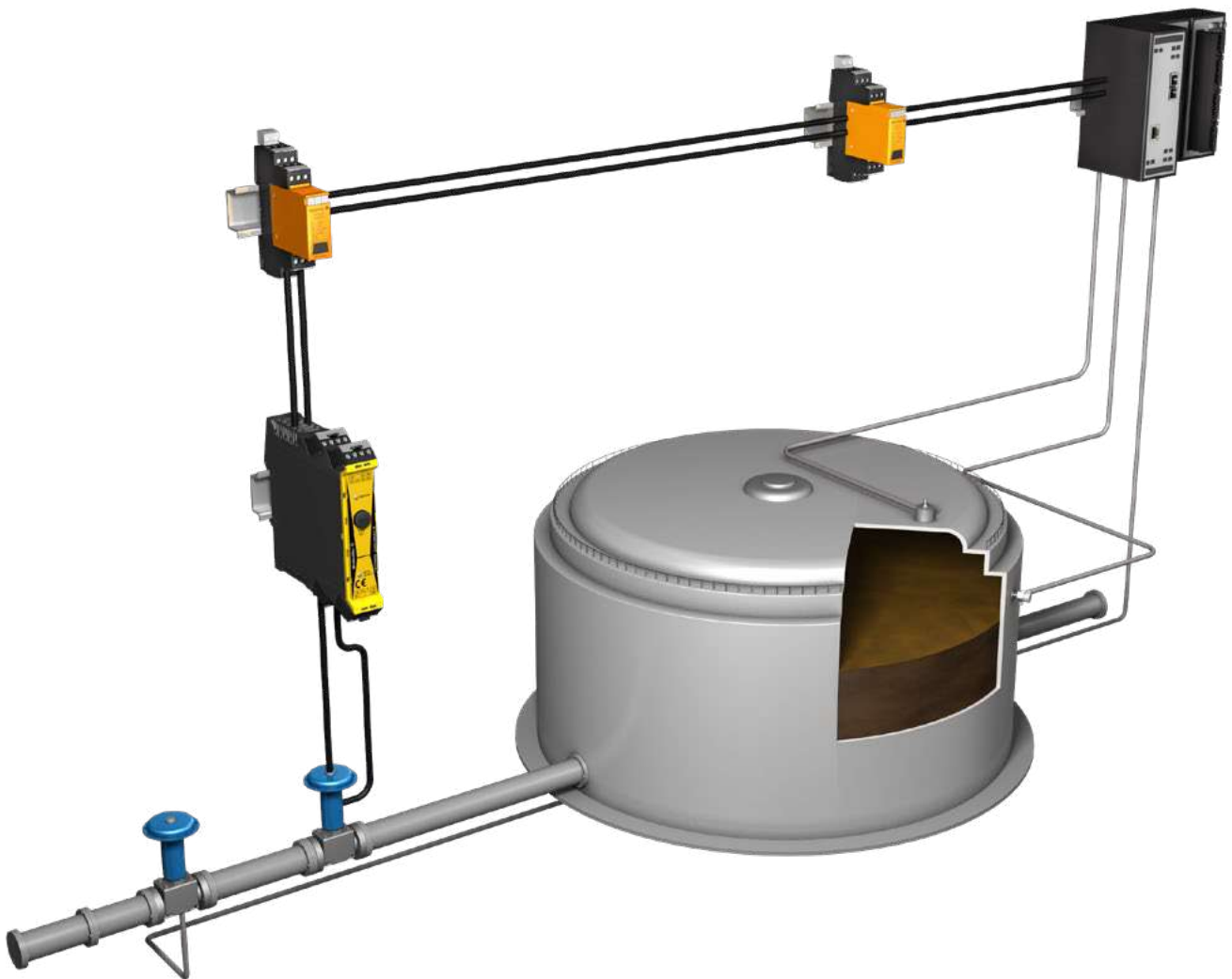

### SAFESERIES

- Certified to EN 61508 for SIL3
- Wide voltage input from 24 to 230 V AC/DC for the monitoring of field signals
- Variant with G3 protection for extreme conditions
- Other variants for burner management or on/off switching



### VARITECTOR SPC

- 2 analogue or 4 digital signals on a width of just 17.8 mm
- Monitoring with status indicator and message function
- Testable with V-TEST according to IEC62305
- Variants with SIL certification or EX approval

# SIL-Relays of the SAFESERIES

## in combination with distributed control systems

C

A distributed control system is characterised by a high availability of hardware and software components. Weidmüller offers for the customer the advantage that his safety relays are working reliably with different distributed control systems, proven by extensive integration tests.



Available for

Order No.	1303890000	1303760000	1304040000	1319270000	2500980000	2634010000
Type	SCS 24VDC P1SIL3DS	SCS 24VDC P1SIL3DS M	SCS 24VDC P1SIL3DS MG3	SCS 24VDC P2SIL3DSES	SCS 24VDC P1SIL3DS I	SCS 24VDC P1SIL3ES LL-T
Order No.						2633940000
Type						SCS 24VDC P1SIL3ES LL
<b>YOKOGAWA</b> ProSafe RS digital output card SDV 541	●	●	●	●		●
ProSafe RS digital output card S2MMM843	●					●
<b>SCHNEIDER ELECTRIC</b> Compatibility with Tricon™, Trident™ and Tri-GP™ systems					●	●
<b>HONEYWELL</b> Can be connected to classic digital output: • Safety Manager IO-Module type FC-SDO-824 und FC-SDOL-0424 • Universal Safety IO-Module type FC-RUSIO-3224	●	●	●	●		●
<b>HIMA</b> HIMax System, output module X-DO 2401	●	●	●			
<b>EMERSON</b> Tested according Delta V SIS test protocols with: • Simplex CHARM LSDO 24VDC DTA (KL3302X1-BA1) • Redundant CHARM LSDO 24VDC DTA (R) (KL3302X1-BB1) • Simplex CHARM LSDO 24VDC ETA (KL3302X1-BC1)	●	●	●	●		●
Tested according Delta V SIS test protocols with: • Simplex CHARM LSDO 24VDC DTA (KL3302X1-BA1) • Redundant CHARM LSDO 24VDC DTA (R) (KL3302X1-BB1)					●	

SIL3 relays

- With and without monitoring circuit
- Wide-range input voltage in the monitoring circuit
- Externally accessible fuse
- TÜV-certified “Approved Safety Function”

Technical data

Temperatures	
Ambient temperature (operational)	-25...50 °C
Storage temperature	-40...85 °C
General data	
Noxious gas resistance to EN 60068-2-60	Yes (art. No.: 1304040000 only)
Input (safety circuit) (A1, A2)	
Rated control voltage	24 V DC ± 20%
Guaranteed current consumption of 24 VDC -10%	35 mA
Power consumption	42 mA
Status indicator	LED yellow
Input (monitor circuit) (M1, M2)	
Rated control voltage	24 V UC...230 V UC ± 10 %
Current consumption	23 mA @ 24 V DC, 4.4 mA @ 230 V AC
Status indicator	LED yellow
Output (safety circuit) (13, 14, 15)	
Contact design	1 x de-energised to safe (NO contact)
max. switching current, internal fuse	5 A (refer to derating curve)
max. switching current, external fuse	5 A (refer to derating curve)
max. permitted switching voltage	250 V AC / 30 V DC
max. permitted switching current	5 A
min. switching power	10 mA @ 12 V
max. switching power	1250 VA
Switch-on time	typ. 7 ms
Base material of the contact	AgNi 0.15 gold flashed
Internal fuse	5 A time-lag
External back-up fuse	5 A time-lag
Short-circuit-proof	No
Output (monitor circuit) (21, 22, 24)	
Contact design	CO contact
max. permitted switching voltage	24 V DC
max. permitted switching current	30 mA
min. switching power	1 mA @ 1 V
Base material of the contact	AgNi 5µm Au
Switch-on time	typ. 17 ms
Short-circuit-proof	No
Insulation coordinates	
Rated voltage	300 V
Clearance and creepage distances for control side - load side	≥ 5.5 mm
Creepage and clearance distance output - output	≥ 5.5 mm
Dielectric strength for control side - load side	4 kV <sub>eff</sub> / 1 min
Dielectric strength output - output	4 kV <sub>eff</sub> / 1 min
Dielectric strength to mounting rail	4 kV <sub>eff</sub> / 1 Min.
Impulse withstand voltage	6 kV (1.2/50 µs)
Overvoltage category	III
Pollution degree	2
Further details of approvals / standards	
Standards	EN 61000, EN 61326-3-2
Approvals	CE; cULus; FUSAFETY; UKCA
Dimensions	
Clamping range (nominal / min. / max.)	1.5 / 0.13 / 2.5 mm <sup>2</sup>
Depth x width x height	114.1 / 22.5 / 117.3 mm
Note	

Ordering data

	with monitoring
	without monitoring
	with monitoring and G3 gas-corrosion resistant
Note	

SCS 24 V DC P1SIL3DS



	-25...50 °C
	-40...85 °C
	Yes (art. No.: 1304040000 only)
	24 V DC ± 20%
	35 mA
	42 mA
	LED yellow
	24 V UC...230 V UC ± 10 %
	23 mA @ 24 V DC, 4.4 mA @ 230 V AC
	LED yellow
	1 x de-energised to safe (NO contact)
	5 A (refer to derating curve)
	5 A (refer to derating curve)
	250 V AC / 30 V DC
	5 A
	10 mA @ 12 V
	1250 VA
	typ. 7 ms
	AgNi 0.15 gold flashed
	5 A time-lag
	5 A time-lag
	No
	CO contact
	24 V DC
	30 mA
	1 mA @ 1 V
	AgNi 5µm Au
	typ. 17 ms
	No
	300 V
	≥ 5.5 mm
	≥ 5.5 mm
	4 kV <sub>eff</sub> / 1 min
	4 kV <sub>eff</sub> / 1 min
	4 kV <sub>eff</sub> / 1 Min.
	6 kV (1.2/50 µs)
	III
	2
	EN 61000, EN 61326-3-2
	CE; cULus; FUSAFETY; UKCA
	1.5 / 0.13 / 2.5
	114.1 / 22.5 / 117.3

Type	Qty.	Order No.
SCS 24VDC P1SIL3DS M	1	1303760000
SCS 24VDC P1SIL3DS	1	1303890000
SCS 24VDC P1SIL3DS MG3	1	1304040000

The SCS 24VDC P1SIL3DS safety relay is used in areas that require a functionally safe shutdown. This component fulfils the requirements of EN 61508, SIL 3.

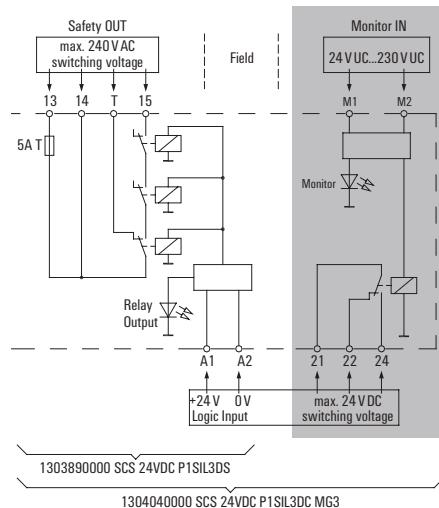

Derating curve safety output

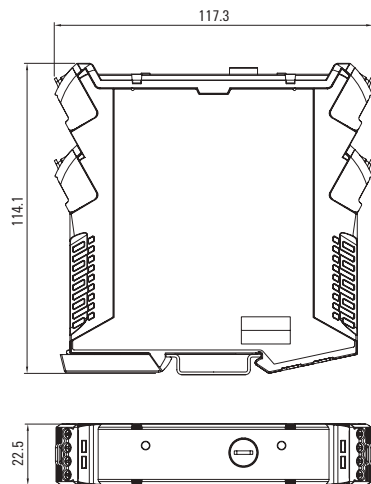
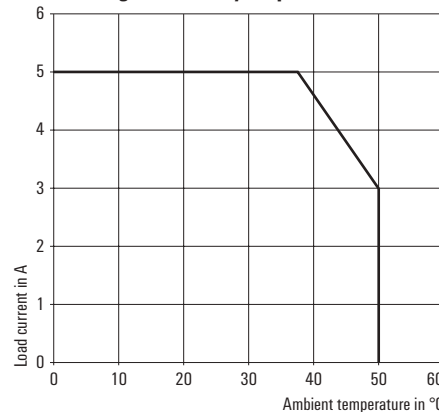

SIL3 relay

- Unresponsive to test pulses from the Triconex® output modules
- Proof of compatibility is available for use with the Tricon™, Trident™ and Tri-GP™ systems.
- Externally accessible fuse
- TÜV-certified “Approved Safety Function”

SCS 24 V DC P1SIL3DS I



The SCS 24VDC P1SIL3DS I safety relay is used in areas that require a functionally safe shutdown. This component fulfils the requirements of EN 61508, SIL 3.

Technical data

<b>Temperatures</b>	
Ambient temperature (operational)	-25...50 °C
Storage temperature	-40...85 °C
<b>Input (safety circuit) (A1, A2)</b>	
Rated control voltage	24 V DC (16...36 V DC)
Power consumption	50 mA
Status indicator	LED yellow
<b>Output (safety circuit) (13, 14, 15)</b>	
Contact design	1 x de-energised to safe (NO contact)
max. switching current, internal fuse	5 A
max. switching current, external fuse	5 A
max. permitted switching voltage	250 V AC / 30 V DC
max. permitted switching current	5 A
min. switching power	10 mA @ 12 V
max. switching power	1250 VA
Switch-on time	≤ 25 ms
Base material of the contact	AgNi
Internal fuse	5 A time-lag
External back-up fuse	5 A time-lag
Short-circuit-proof	No
<b>Insulation coordinates</b>	
Rated voltage	300 V
Clearance and creepage distances for control side - load side	≥ 6 mm
Dielectric strength for control side - load side	3.51 kV <sub>eff</sub> /5 s
Dielectric strength to mounting rail	
Impulse withstand voltage	6 kV (1.2/50 µs)
Overvoltage category	III
Pollution degree	2
<b>Further details of approvals / standards</b>	
Standards	EN 61010-2-201:2013 + AC:2013, EN 61326-1, EN 61326-3-1, EN 61326-3-2
Approvals	CE; cULus; FUSAFETY; UKCA

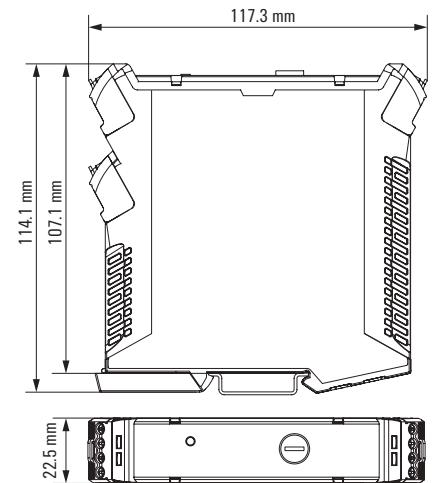
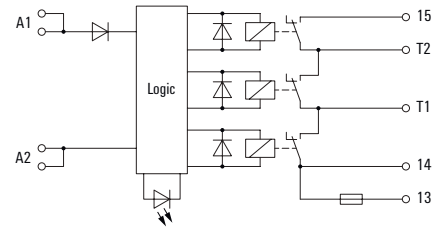

<b>Dimensions</b>	
Clamping range (nominal / min. / max.)	mm <sup>2</sup> 1.5 / 0.13 / 2.5
Depth x width x height	mm 114.1 / 22.5 / 117.3
<b>Note</b>	

Ordering data

	with monitoring	
<b>Type</b>	<b>Qty.</b>	<b>Order No.</b>
SCS 24VDC P1SIL3DS I	1	2500980000
<b>Note</b>		

**SIL3 relays**

- Energized/de-energized to safe
- All-pole disconnection possible
- Test inputs for testing the relay contacts
- Externally accessible fuse
- TÜV-certified “Approved Safety Function”

**SCS 24 V DC P2SIL3DSES**



The safety relay SCS 24VDC P2SIL3DSES is used in areas that require functionally safe deactivation or activation. The requirements according to EN 61508, SIL3 can be fulfilled with this module.

**Technical data**

Temperatures	
Ambient temperature (operational)	-25 °C...50 °C
Storage temperature	-40 °C...85 °C
Input (safety circuit) (A1, A2)	
Rated control voltage	24 V DC -15 / +20%
Guaranteed current consumption of 24 VDC -10%	35 mA
Power consumption	45 mA
Status indicator	LED yellow
Test inputs (X1, X2, X3)	
Rated control voltage	24 V DC
Status indicator	LED red flashing: test input is triggered
Number of test inputs	2
Output (safety circuit) (13, 14, 23, 24)	
Contact design	1 x de-energised to safe (NO contact), 1 x energised to safe (NO contact)
max. switching current, internal fuse	5 A (refer to derating curve)
max. switching current, external fuse	5 A (refer to derating curve)
max. permitted switching voltage	250 V AC
max. permitted switching current	5 A
min. switching power	10 mA @ 12 V
max. switching power	1250 VA
Switch-on time	<5.5 ms (DTS), <5 ms (ETS)
Base material of the contact	AgNi 0.15 gold flashed
Internal fuse	5 A time-lag
External back-up fuse	5 A time-lag
Short-circuit-proof	No
Insulation coordinates	
Rated voltage	300 V
Clearance and creepage distances for control side - load side	≥ 5.5 mm
Creepage and clearance distance output - output	≥ 5.5 mm
Dielectric strength for control side - load side	4 kV <sub>eff</sub> / 1 min
Dielectric strength output - output	4 kV <sub>eff</sub> / 1 min
Dielectric strength to mounting rail	4 kV <sub>eff</sub> / 1 Min.
Impulse withstand voltage	6 kV (1.2/50 µs)
Overvoltage category	III
Pollution degree	2
Further details of approvals / standards	
Standards	EN 61000, EN 61326-3-2
Approvals	CE; FUSAFETY

Dimensions	
Clamping range (nominal / min. / max.)	mm <sup>2</sup> 1.5 / 0.13 / 2.5
Depth x width x height	mm 114.1 / 22.5 / 117.3
Note	

**Ordering data**

Type	Qty.	Order No.
SCS 24VDC P2SIL3DSES	1	1319270000
Note		

Rated control voltage	24 V DC -15 / +20%
Guaranteed current consumption of 24 VDC -10%	35 mA
Power consumption	45 mA
Status indicator	LED yellow
Rated control voltage	24 V DC
Status indicator	LED red flashing: test input is triggered
Number of test inputs	2
Contact design	1 x de-energised to safe (NO contact), 1 x energised to safe (NO contact)
max. switching current, internal fuse	5 A (refer to derating curve)
max. switching current, external fuse	5 A (refer to derating curve)
max. permitted switching voltage	250 V AC
max. permitted switching current	5 A
min. switching power	10 mA @ 12 V
max. switching power	1250 VA
Switch-on time	<5.5 ms (DTS), <5 ms (ETS)
Base material of the contact	AgNi 0.15 gold flashed
Internal fuse	5 A time-lag
External back-up fuse	5 A time-lag
Short-circuit-proof	No
Rated voltage	300 V
Clearance and creepage distances for control side - load side	≥ 5.5 mm
Creepage and clearance distance output - output	≥ 5.5 mm
Dielectric strength for control side - load side	4 kV <sub>eff</sub> / 1 min
Dielectric strength output - output	4 kV <sub>eff</sub> / 1 min
Dielectric strength to mounting rail	4 kV <sub>eff</sub> / 1 Min.
Impulse withstand voltage	6 kV (1.2/50 µs)
Overvoltage category	III
Pollution degree	2
Standards	EN 61000, EN 61326-3-2
Approvals	CE; FUSAFETY

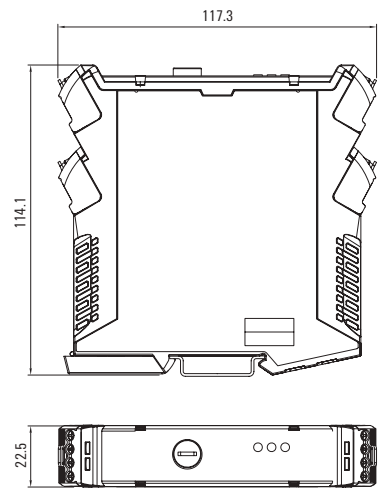
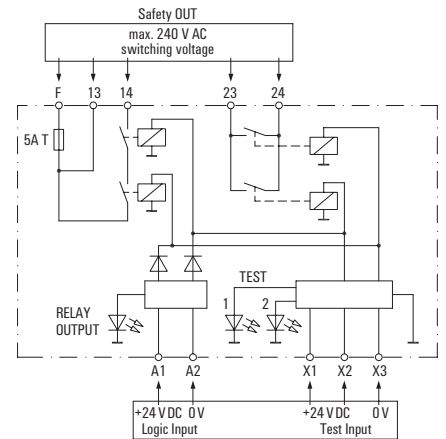

SIL3 relays

- Positively-driven contacts
- 2-channel design
- Insert according to EN 50156
- TÜV-certified “Approved Safety Function”

SCS 24 V DC P2SIL3ES



The feed-in of fuel must be interrupted as soon as a boiler plant reaches any safety criterion limits. The safety relay SCS 24VDC P2SIL3ES enables you to carry out a safety shutdown of the fuel supply, to safety level SIL 3.

Technical data

Temperatures	
Ambient temperature (operational)	-25 °C...55 °C
Storage temperature	-40 °C...85 °C
Start circuit (S33, S34, S35)	
Operating voltage	22 V DC, from internal power supply
Function	falling edge (button via S33/S34), rising edge (permanent bridge via S33/S35)
Input (supply) (A1, A2, C1, C2)	
Rated control voltage	24 V DC ±15 %, 24 VDC +15% / -10% during auto-start
Current consumption	55 mA (release circuit enabled), 6 mA (release circuit not enabled)
Guaranteed current consumption at 24 V DC -10%	35 mA
Response time	with bridge via C1/C2: typ. 50 ms, without bridge via C1/C2: typ. 20 ms
Status display	LED green: supply, Yellow LED: signal
Short-circuit detection	Yes, max. 4 s up to disconnection (thermistor)
Monitoring circuit (S11, S12, S21, S22)	
Operating voltage	22 V DC, from internal power supply
Input	2, each externally bridgeable
Output (release circuit) (13, 14, 23, 24)	
Contact version	2 NO positively-driven (EN 50205 type B)
Switching voltage AC, max.	250.000000 V
max. permitted switching current	5 A
min. switching power	10 mA @ 12 V
max. switching power	1250 VA
Switch-on time	55 ms (C1/C2 bridged, switched via A1/A2), 30 ms (opening/closing of monitoring circuit)
Switch-off time	55 ms (C1/C2 bridged, switched via A1/A2), 15 ms (opening/closing of monitoring circuit)
Contact base material	AgSnO
max. switching current, external fuse	5 A
external back-up fuse	5 A time-lag
Feedback output (31, 32)	
Contact version	1 NC positively-driven (EN 50205 type B)
Switching voltage AC, max.	250 V
Max. switching current	1 A
Insulation coordinates	
Rated voltage	300 V
Clearance and creepage distances for control side - load side	≥ 5.5 mm
Creepage and clearance distance output - output	≥ 5.5 mm
Dielectric strength for control side - load side	4 kV <sub>eff</sub> / 1 min
Dielectric strength output - output	4 kV <sub>eff</sub> / 1 min
Dielectric strength to mounting rail	4 kV <sub>eff</sub> / 1 Min.
Impulse withstand voltage	6 kV (1.2/50 μs)
Overvoltage category	III
Pollution degree	2
Further details of approvals / standards	
Standards	EN 61000, EN 61326-3-2, EN ISO 13849-1 (PLe)
Approvals	CE; FUSAFETY
Dimensions	
Clamping range (nominal / min. / max.)	1.5 / 0.13 / 2.5 mm <sup>2</sup>
Depth x width x height	114.1 / 22.5 / 119.6 mm
Note	

Ordering data

Type	Qty.	Order No.
SCS 24VDC P2SIL3ES	1	1319280000
Note		

Temperatures	
Ambient temperature (operational)	-25 °C...55 °C
Storage temperature	-40 °C...85 °C
Start circuit (S33, S34, S35)	
Operating voltage	22 V DC, from internal power supply
Function	falling edge (button via S33/S34), rising edge (permanent bridge via S33/S35)
Input (supply) (A1, A2, C1, C2)	
Rated control voltage	24 V DC ±15 %, 24 VDC +15% / -10% during auto-start
Current consumption	55 mA (release circuit enabled), 6 mA (release circuit not enabled)
Guaranteed current consumption at 24 V DC -10%	35 mA
Response time	with bridge via C1/C2: typ. 50 ms, without bridge via C1/C2: typ. 20 ms
Status display	LED green: supply, Yellow LED: signal
Short-circuit detection	Yes, max. 4 s up to disconnection (thermistor)
Monitoring circuit (S11, S12, S21, S22)	
Operating voltage	22 V DC, from internal power supply
Input	2, each externally bridgeable
Output (release circuit) (13, 14, 23, 24)	
Contact version	2 NO positively-driven (EN 50205 type B)
Switching voltage AC, max.	250.000000 V
max. permitted switching current	5 A
min. switching power	10 mA @ 12 V
max. switching power	1250 VA
Switch-on time	55 ms (C1/C2 bridged, switched via A1/A2), 30 ms (opening/closing of monitoring circuit)
Switch-off time	55 ms (C1/C2 bridged, switched via A1/A2), 15 ms (opening/closing of monitoring circuit)
Contact base material	AgSnO
max. switching current, external fuse	5 A
external back-up fuse	5 A time-lag
Feedback output (31, 32)	
Contact version	1 NC positively-driven (EN 50205 type B)
Switching voltage AC, max.	250 V
Max. switching current	1 A
Insulation coordinates	
Rated voltage	300 V
Clearance and creepage distances for control side - load side	≥ 5.5 mm
Creepage and clearance distance output - output	≥ 5.5 mm
Dielectric strength for control side - load side	4 kV <sub>eff</sub> / 1 min
Dielectric strength output - output	4 kV <sub>eff</sub> / 1 min
Dielectric strength to mounting rail	4 kV <sub>eff</sub> / 1 Min.
Impulse withstand voltage	6 kV (1.2/50 μs)
Overvoltage category	III
Pollution degree	2
Further details of approvals / standards	
Standards	EN 61000, EN 61326-3-2, EN ISO 13849-1 (PLe)
Approvals	CE; FUSAFETY
Dimensions	
Clamping range (nominal / min. / max.)	1.5 / 0.13 / 2.5 mm <sup>2</sup>
Depth x width x height	114.1 / 22.5 / 119.6 mm
Note	

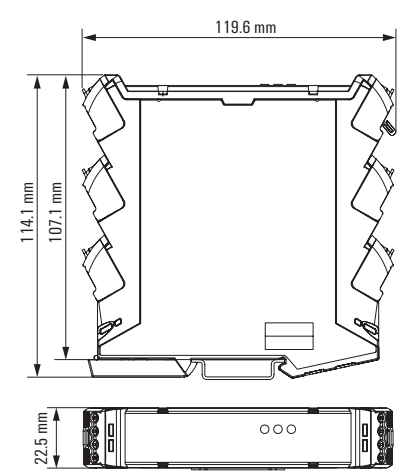
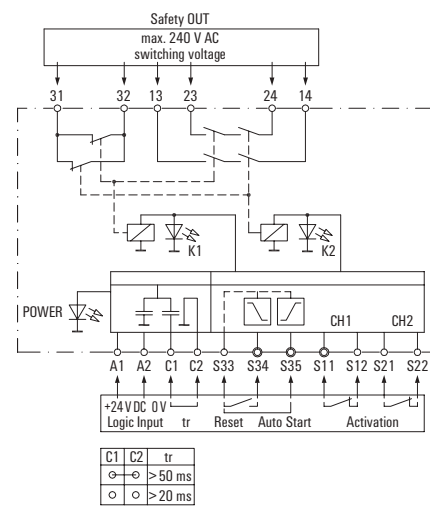



SIL3 relays

- Wire break detection and load monitoring in load circuit
- Energized to safe
- Approvals for Ex-areas
- 17,5 mm width
- TÜV-certified “Approved Safety Function”
- Ambient temperature (operational): max 50 °C

SCS 24VDC P1SIL3ES LL



The safety relay SCS 24VDC P1SIL3ES LL is used in areas that require functionally safe activation. The integrated diagnostic function enables monitoring of wire breakage and load errors on the load side.

The requirements according to EN 61508, SIL3 can be met with this component. The safety relay can be operated at ambient temperatures of up to 50 °C without switching current derating.

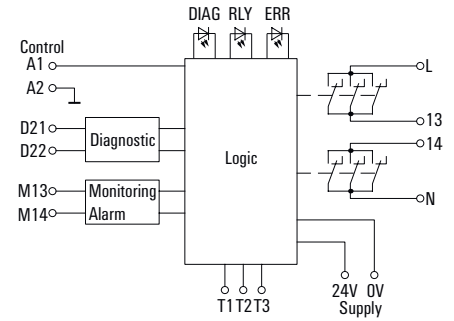

Technical data

<b>Temperatures</b>	
Ambient temperature (operational)	-40 °C...50 °C
Storage temperature	-40 °C...85 °C
<b>Input (supply) (OV, 24V)</b>	
Rated control voltage	24 V DC ±20 %
Current consumption	< 40 mA + M14
<b>Input (safety circuit) (A1, A2)</b>	
Rated control voltage	24 V DC ± 20%
Power consumption	56 mA
Status indicator	LED yellow (RLY): lights up when input circuit (A1,A2) of the device is actuated
<b>Test inputs (T1, T2, T3)</b>	
Rated control voltage	24 V DC ±20 %
<b>Output (safety circuit) (L, N, 13, 14)</b>	
Contact design	1 x energised to safe (NO contact)
max. switching current, external fuse	2,5 A
max. permitted switching voltage	250 V AC
max. switching power	625 VA
min. switching power	30 mA @ 15 V
Switch-on time	50 ms
<b>Alarm output (M13, M14)</b>	
Contact design	
Output current, max.	100 mA
Status indicator (Alarm output)	LED red (ERR): flashes when device detects a fault, supply voltage applied and input circuit (A1, A2) not actuated
Short-circuit-proof	
<b>Diagnosis output (D21, D22)</b>	
Contact design	1 NC contact
Switching voltage, max.	30 V
Switching, current, max.	100 mA
Switching capacity, min.	1 mW
Status indicator	LED green (DIAG): lights up when supply voltage applied and input circuit (A1, A2) not actuated
<b>Insulation coordinates</b>	
Rated voltage	300 V
Clearance and creepage distances for control side - load side	≥ 6 mm
Creepage and clearance distance output - output	≥ 6 mm
Dielectric strength for control side - load side	3.51 kV <sub>eff</sub> /1 min.
Dielectric strength output - output	3.51 kV <sub>eff</sub> /1 min.
Overvoltage category	III
Pollution degree	2
<b>Further details of approvals / standards</b>	
Approvals	CCCEX; CE; cULus; cULusEX; DEMKOATEX; FUSAFETY; IECEXULD; UKEX; UKCA
Standards	EN 61010-1, EN 61010-2-201, EN 61326-3-2, EN 61326-1, EN 61326-3-1, DIN EN 61508
<b>Dimensions</b>	
Clamping range (nominal / min. / max.)	1.5 / 0.13 / 2.5 mm <sup>2</sup>
Depth x width x height	119.2 / 17.5 / 113.6 mm
<b>Note</b>	

Ordering data

<b>Type</b>	
SCS 24VDC P1SIL3ES LL	
<b>Qty.</b>	
1	
<b>Order No.</b>	
2633940000	
<b>Note</b>	

DC Load breaking curve safety output

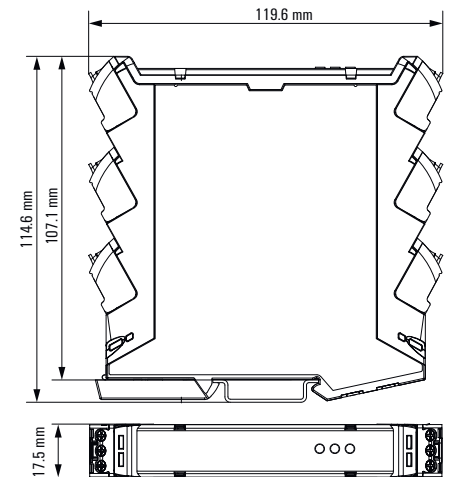
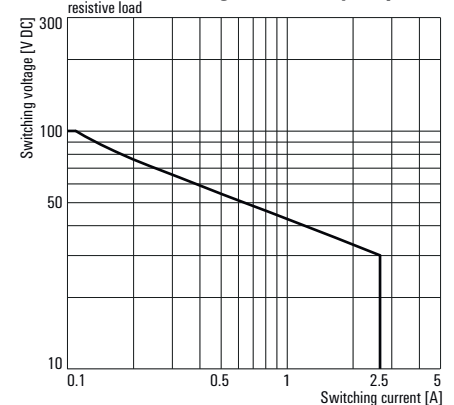

**SIL3 relays**

- Wire break detection and load monitoring in load circuit
- Energized to safe
- Approvals for Ex-areas
- 22,5 mm width
- TÜV-certified “Approved Safety Function”
- Ambient temperature (operational): max 70 °C

**SCS 24VDC P1SIL3ES LL-T**



The safety relay SCS 24VDC P1SIL3ES LL-T is used in areas that require functionally safe activation. The integrated diagnostic function enables monitoring of wire breakage and load errors on the load side. The requirements according to EN 61508, SIL3 can be met with this component. The safety relay can be operated at ambient temperatures of up to 70 °C without switching current derating.

**Technical data**

<b>Temperatures</b>	
Ambient temperature (operational)	-40 °C...70 °C
Storage temperature	-40 °C...85 °C
<b>Input (supply) (0V, 24V)</b>	
Rated control voltage	24 V DC ±20 %
Current consumption	< 40 mA + M14
<b>Input (safety circuit) (A1, A2)</b>	
Rated control voltage	24 V DC ± 20%
Power consumption	71 mA
Status indicator	LED yellow (RLY): lights up when input circuit (A1,A2) of the device is actuated
<b>Test inputs (T1, T2, T3)</b>	
Rated control voltage	24 V DC ±20 %
<b>Output (safety circuit) (L, N, 13, 14)</b>	
Contact design	1 x energised to safe (NO contact)
max. switching current, external fuse	2,5 A
max. permitted switching voltage	250 V AC
max. switching power	625 VA
min. switching power	30 mA @ 15 V
Switch-on time	50 ms
<b>Alarm output (M13, M14)</b>	
Contact design	
Output current, max.	100 mA
Status indicator (Alarm output)	LED red (ERR): flashes when device detects a fault, supply voltage applied and input circuit (A1, A2) not actuated
Short-circuit-proof	
<b>Diagnosis output (D21, D22)</b>	
Contact design	1 NC contact
Switching voltage, max.	30 V
Switching, current, max.	100 mA
Switching capacity, min.	1 mW
Status indicator	LED green (DIAG): lights up when supply voltage applied and input circuit (A1, A2) not actuated
<b>Insulation coordinates</b>	
Rated voltage	300 V
Clearance and creepage distances for control side - load side	≥ 6 mm
Creepage and clearance distance output - output	≥ 6 mm
Dielectric strength for control side - load side	3.51 kV <sub>eff</sub> /1 min.
Dielectric strength output - output	3.51 kV <sub>eff</sub> /1 min.
Overvoltage category	III
Pollution degree	2
<b>Further details of approvals / standards</b>	
Approvals	CCCEX; CE; cULus; cULusEX; DEMKOATEX; FUSAFETY; IECEXULD; UKEX; UKCA
Standards	
<b>Dimensions</b>	
Clamping range (nominal / min. / max.)	mm <sup>2</sup> 1.5 / 0.13 / 2.5
Depth x width x height	mm 119.2 / 22.5 / 113.6
<b>Note</b>	

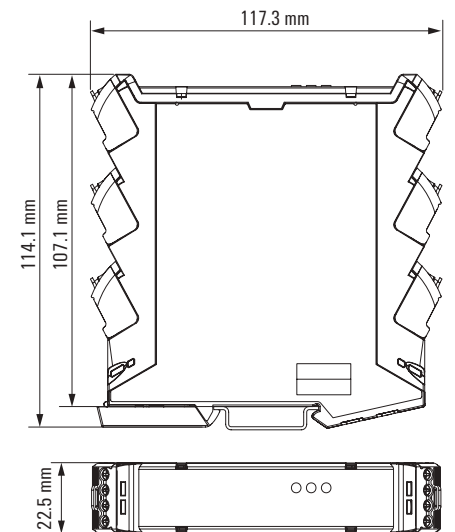
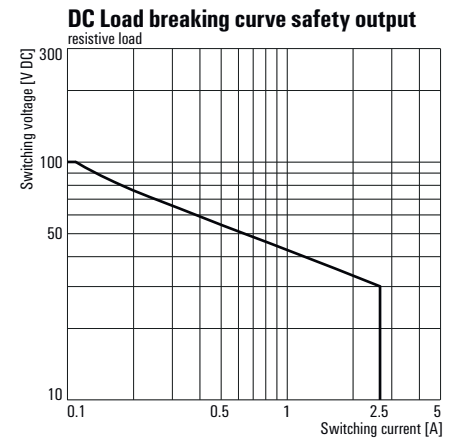
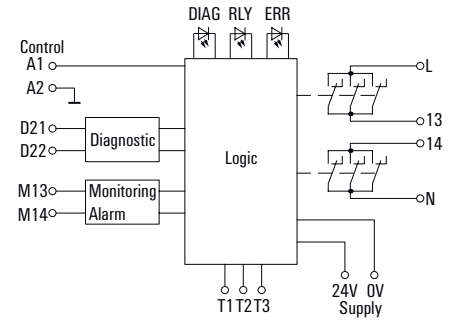

**Ordering data**

Type	Qty.	Order No.
SCS 24VDC P1SIL3ES LL-T	1	2634010000
<b>Note</b>		

# SAFESERIES Contact Extension

## Pluggable relay modules with positively driven contacts

### C

Relay modules with positively driven contacts are used for functional safety. The SAFESERIES Contact Extension uses relays with forcibly guided contacts in accordance with EN 61810-3 Type A. This makes it predestined for signal monitoring in applications for the protection of people and machinery.

The SAFESERIES Contact Extension ensures safe feedback to the control level. It consists of five different pluggable relays with matching screw sockets in the contact version 2 NO + 2 NC, 3 NO + 1 NC, 5 NO + 1 NC, 4 NO + 2 NC, and 3 NO + 3 NC. When the application is designed according to EN/ISO 13849-1, a performance level of PL „e“ can be achieved. The basic component is also suitable for safety applications according to IEC/EN 62061 in order to achieve a safety integrity level of SIL3.



**Easy installation**

The socket allows easy installation on the mounting rail. It features a freewheeling diode, a status LED, and an ejection lever. The use of ring and fork cable lugs is possible.

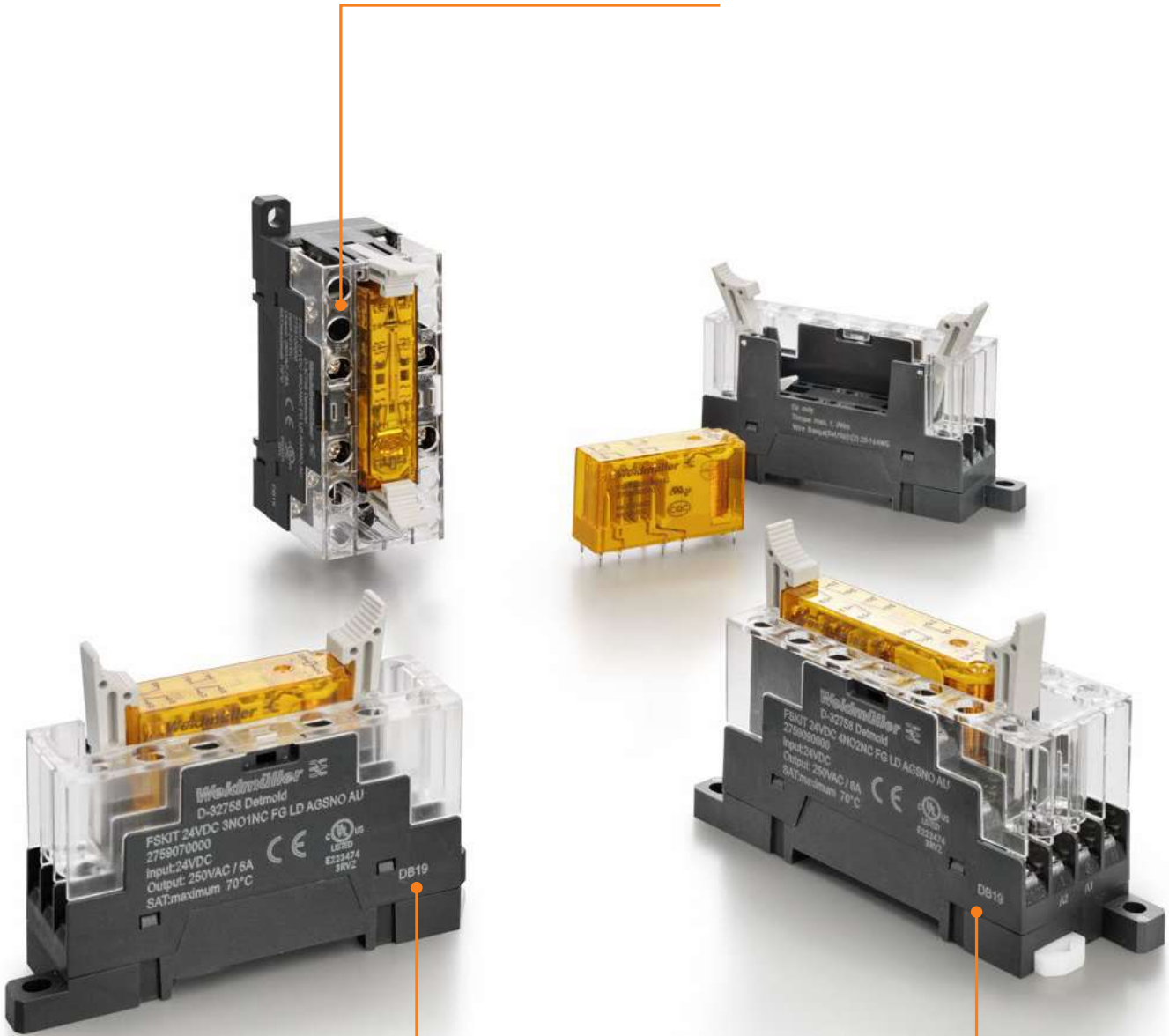

**Proven component**

Suitable as a safe contact multiplier with matching safety switching devices and the remote I/O system „u-remote“. The positive drive ensures synchronous switching status at the contacts and achieves a diagnostic coverage of 99 %.

**Comprehensive approvals**

The cULus listed designation saves the cost of an overall system approval in North America. The CQC marking proves conformity with Chinese quality, environmental, and performance standards.

4 Kontakte



2 NO 2 NC

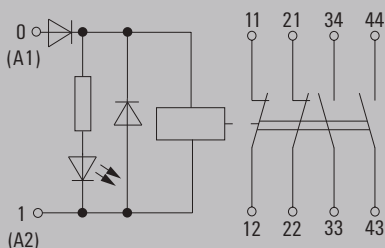

3 NO 1 NC

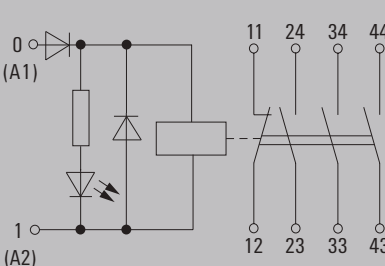

Technical data

Load side	
Rated switching voltage / Continuous current	250 V AC / 6 A
Max. switching voltage, AC	400 V
Inrush current	30 A / 20 ms
Min. switching power	2 mA @ 24 V, 10 mA @ 12 V, 100 mA @ 5 V
Mechanical service life	10 x 10 <sup>6</sup> switching cycles
Max. switching frequency at rated load	0.1 Hz
General data	
Ambient temperature (operational)	-40 °C...70 °C
Storage temperature	-40 °C...70 °C
Humidity	5...85 % rel. humidity, no condensation
Approvals	CE, cULus, UKCA
Insulation coordinates	
Rated voltage	250 V
Impulse withstand voltage	
Dielectric strength for control side - load side	2.5 kV <sub>eff</sub> / 1 min.
Dielectric strength of neighbouring contacts	2.5 kV <sub>eff</sub> / 1 Min.
Dielectric strength to mounting rail	4 kV <sub>eff</sub> / 1 Min.
Clearance and creepage distances for control side - load side	≥ 3 mm
Overvoltage category	III
Pollution degree	2

Dimensions	Screw connection
Clamping range (nominal / min. / max.)	mm <sup>2</sup> 1.5 / 0.5 / 1.5
Depth x width x height	mm 59.8 / 22.4 / 89.4

Note

Applications

Electrical endurance  
250 V AC resistive load

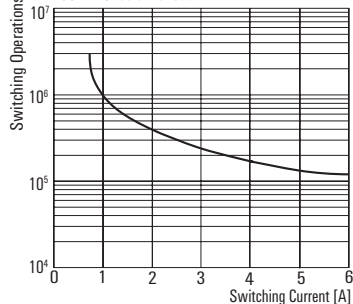

DC load breaking capacity  
Resistive load

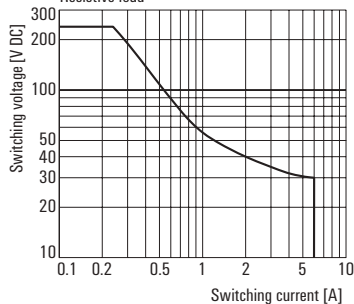

Dimensioned drawing

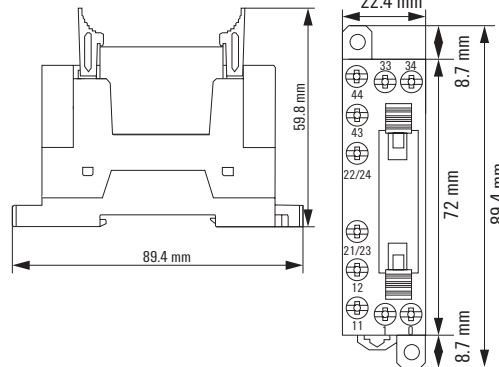

4 Contacts

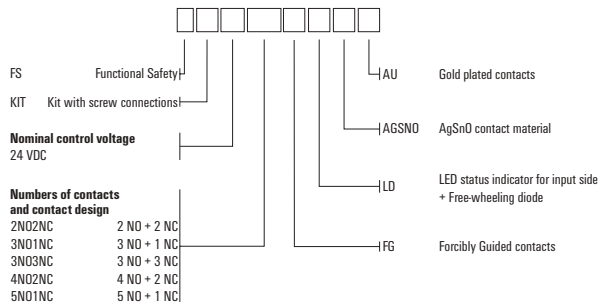

Ordering data

Control side	
Rated control voltage	24 V DC ±10 %
Rated current AC / DC	/ 20 mA
Power rating	480 mW
Status indicator	Green LED
Protective circuit	Free-wheeling diode
Contact type	2 NC and 2 NO contacts forcibly guided (EN 61810-3 type A) (AgSnO gold-plated)

24 V DC 2NO2NC	
Rated control voltage	24 V DC ±10 %
Rated current AC / DC	/ 20 mA
Power rating	480 mW
Status indicator	Green LED
Protective circuit	Free-wheeling diode
Contact type	2 NC and 2 NO contacts forcibly guided (EN 61810-3 type A) (AgSnO gold-plated)

24 V DC 3NO1NC	
Rated control voltage	24 V DC ±10 %
Rated current AC / DC	/ 20 mA
Power rating	480 mW
Status indicator	Green LED
Protective circuit	Free-wheeling diode
Contact type	1 NC and 3 NO contacts forcibly guided (EN 61810-3 type A) (AgSnO gold-plated)

Ordering data	
Screw connection	Type
Order No.	Type
Order No.	Type
Note	

FSKIT 24VDC 2NO2NC FG LD AGSNO AU
<b>2759080000</b>

FSKIT 24VDC 3NO1NC FG LD AGSNO AU
<b>2759070000</b>

6 contacts

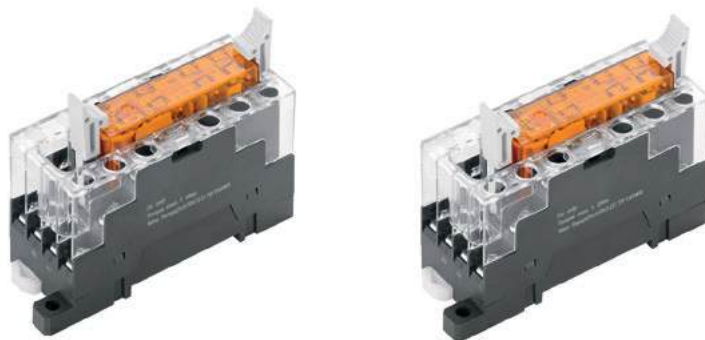

3 NO 3 NC

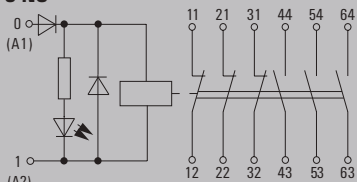

4 NO 2 NC

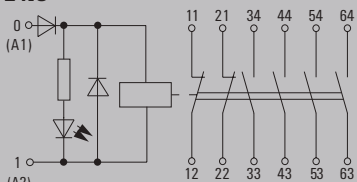

5 NO 1 NC

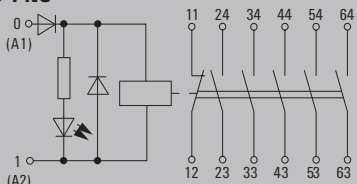

Technical data

Load side	
Rated switching voltage / Continuous current	250 V AC / 6 A
Max. switching voltage, AC	400 V
Inrush current	30 A / 20 ms
Min. switching power	2 mA @ 24 V, 10 mA @ 12 V, 100 mA @ 5 V
Mechanical service life	10 x 10 <sup>6</sup> switching cycles
Max. switching frequency at rated load	0.1 Hz
General data	
Ambient temperature (operational)	-40 °C...70 °C
Storage temperature	-40 °C...70 °C
Humidity	5...85 % rel. humidity, no condensation
Approvals	CE, cULus, UKCA
Insulation coordinates	
Rated voltage	250 V
Impulse withstand voltage	
Dielectric strength for control side - load side	2.5 kV <sub>eff</sub> / 1 min.
Dielectric strength of neighbouring contacts	2.5 kV <sub>eff</sub> / 1 Min.
Dielectric strength to mounting rail	4 kV <sub>eff</sub> / 1 Min.
Clearance and creepage distances for control side - load side	≥ 3 mm
Overvoltage category	III
Pollution degree	2
Dimensions	
Clamping range (nominal / min. / max.)	mm <sup>2</sup> 1.5 / 0.5 / 1.5
Depth x width x height	mm 59.8 / 29.8 / 89.4
Note	

Applications

Electrical endurance

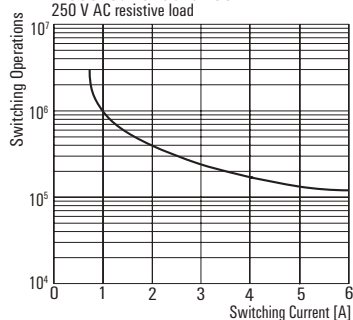

DC load breaking capacity

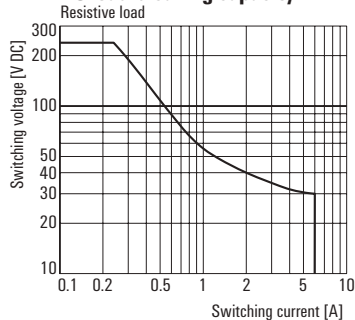

Dimensioned drawing

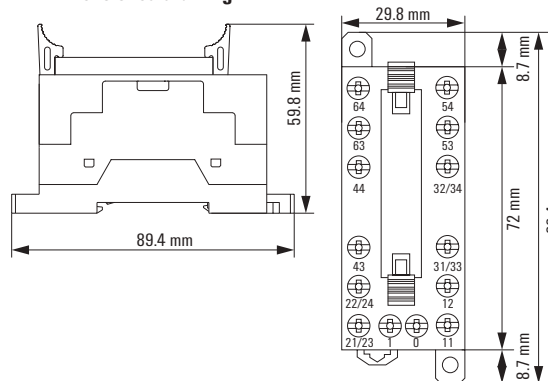

6 contacts

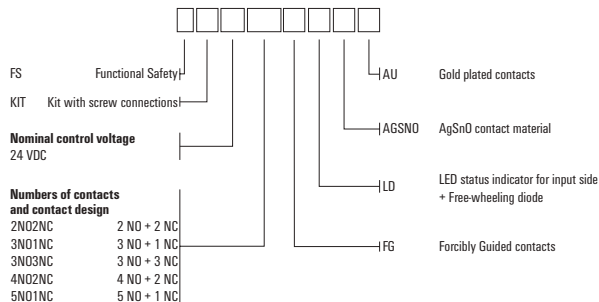

Ordering data

Control side	24 V DC 3NO 3NC	24 V DC 4NO 2NC	24 V DC 5NO 1NC
Rated control voltage	24 V DC ±10 %	24 V DC ±10 %	24 V DC ±10 %
Rated current AC / DC	/ 25.5 mA	/ 25.5 mA	/ 25.5 mA
Power rating	620 mW	620 mW	620 mW
Status indicator	Green LED	Green LED	Green LED
Protective circuit	Free-wheeling diode	Free-wheeling diode	Free-wheeling diode
Contact type	3 NC and 3 NO contacts forcibly guided (EN 61810-3 type A) (AgSnO gold-plated)	2 NC and 4 NO contacts forcibly guided (EN 61810-3 type A) (AgSnO gold-plated)	1 NC and 5 NO contacts forcibly guided (EN 61810-3 type A) (AgSnO gold-plated)

Ordering data			
Screw connection	Type	FSKIT 24VDC 3NO3NC FG LD AGSNO AU	FSKIT 24VDC 4NO2NC FG LD AGSNO AU
Order No.	Type	<b>2759100000</b>	<b>2759090000</b>
Order No.	Type		
Note			

Application range

C

## TERMSERIES FG

### Proven switching condition monitoring of signals

#### C

In safety-related applications, relays with positively-driven contacts have proven themselves many times over. The positively-driven operation ensures a synchronous switching status at both contacts, so that the signal contact maintains the same switching status in the event of an error. Thus, diagnostic coverage of 99% is achieved.

Our TERMSERIES relay modules are predestined for secure signal monitoring in a wide range of applications. Their switching function is clearly indicated by an illuminated ejection lever, which also has an integrated marker holder. Compatibility with all accessories from the TERMSERIES allows high flexibility and easy integration into existing systems. TERMSERIES relay modules have the cULus certification required for use in the North American market.

#### Your special advantages:

- Relay modules for monitoring signals for opening failure
- Two positively-driven CO contacts in accordance with EN 61810-3 type B
- Optional with screw and PUSH IN connection
- “cULus Listed” certification for use in the North American market



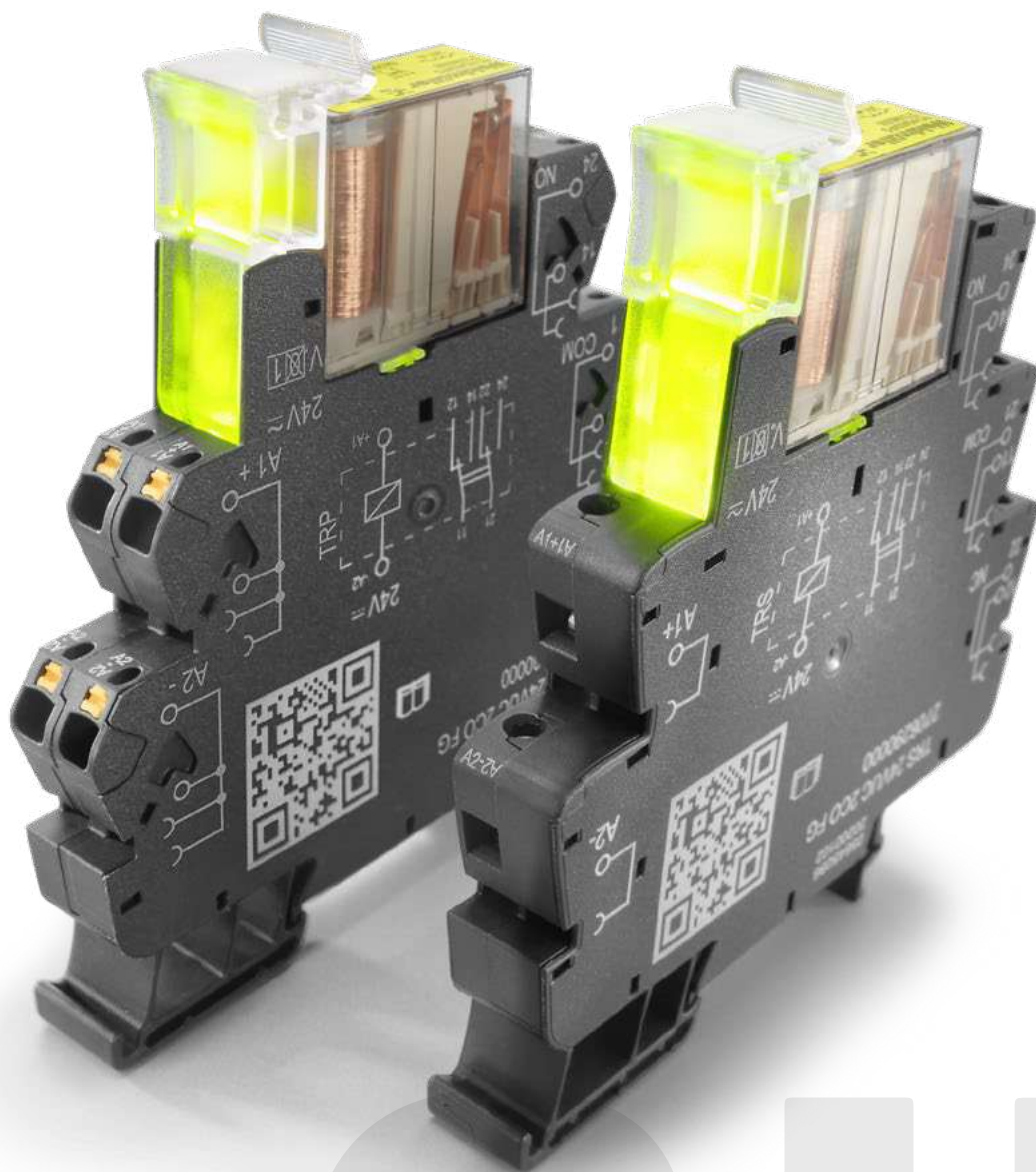

**TERMSERIES FG**

- Complete module with relay
- Space-saving 12.8 mm width
  - AgNi contact
  - Bright shining status LED
  - With protective circuitry
  - PUSH IN and screw connection

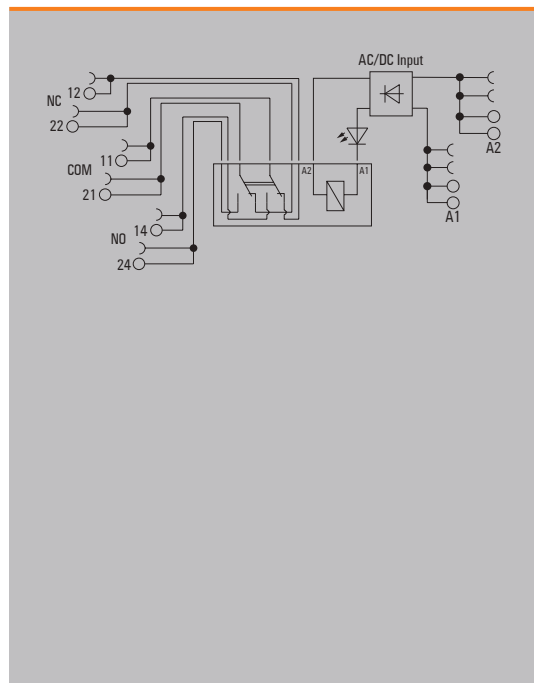

**Technical data**

Load side		
Rated switching voltage / Continuous current	250 V AC / 6 A	
Max. switching voltage, AC	250 V	
Inrush current		
Min. switching power	10 mA @ 5 V	
Contact type	2 CO contacts forcibily guided (EN 61810-3 type B) (AgNi)	
Mechanical service life	10 x 10 <sup>6</sup> switching cycles	
Max. switching frequency at rated load	0.1 Hz	
General data		
Ambient temperature (operational)	-25 °C...60 °C	
Storage temperature	-25 °C...70 °C	
Humidity	5...85 %, no condensation	
Approvals	CE; cULus; UKCA	
Insulation coordinates		
Rated voltage	300 V	
Impulse withstand voltage		
Dielectric strength for control side - load side	3.51 kV <sub>eff</sub> / 1 min.	
Dielectric strength of neighbouring contacts	2.21 kV <sub>eff</sub> / 1 min.	
Dielectric strength to mounting rail	3.51 kV <sub>eff</sub> / 1 min.	
Clearance and creep distances for control side - load side	≥ 6 mm	
Overvoltage category	III	
Pollution degree	2	
Dimensions		
	<b>PUSH IN</b>	<b>Screw connection</b>
Clamping range (nominal / min. / max.)	mm <sup>2</sup> 1.5 / 0.14 / 2.5	1.5 / 0.14 / 2.5
Depth x width x height	mm 97.5 / 12.8 / 89.6	97.5 / 12.8 / 89.6
<b>Note</b>	Accessories and dimensional drawings: refer to the TERMSERIES Accessories page. Further approvals and technical data can be found at <a href="http://eshop.weidmueller.com">eshop.weidmueller.com</a>	

**Applications**

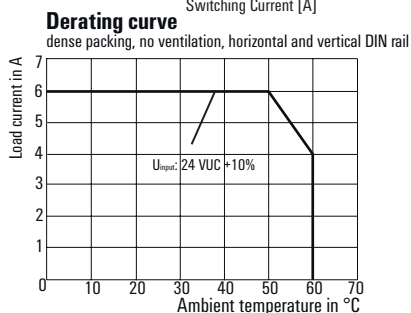
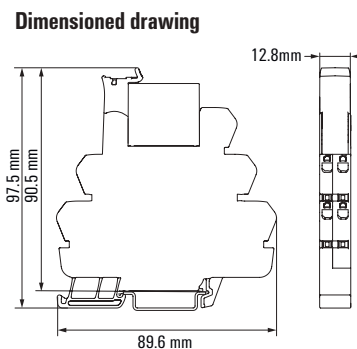
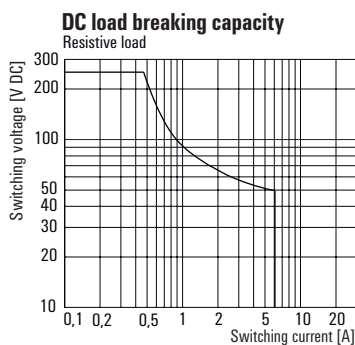
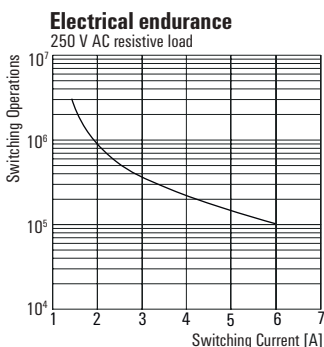

TERMSERIES FG

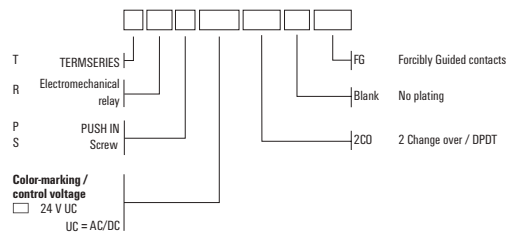

Ordering data

Control side		24 V UC
Rated control voltage		24 V UC ±10 %
Rated current AC / DC		24.4 mA / 23.5 mA
Power rating		585 mVA, 565 mW
Status indicator		Green LED
Protective circuit		Rectifier

Ordering data		
PUSH IN connection	Type	TRP 24VUC 2CO FG
	Order No.	<b>2706430000</b>
Screw connection	Type	TRS 24VUC 2CO FG
	Order No.	<b>2706290000</b>

Ordering data		
Spare relay	Type	RCH424024FG
	Order No.	<b>2723360000</b>

Note		

# Power

## Special relays for high industrial loads

**C** If currents above 10 A have to be switched, standard relays are subject to high wear and quickly reach the limits of their service life. Our power switches has been specially developed to control high AC loads. They are ideally suited for motors or heating elements up to 35 A and can be used in many other power applications.

### **Power solid-state relays (PSSR) up to 30 A**

Our solid-state contactors are far superior to mechanical contactors. They achieve higher switching speeds and are more robust and durable. They switch ohmic and inductive loads silently, wear-free and reliably – even in dusty or chemically aggressive atmospheres.

### **Miniature contactors (PWR) up to 30 A**

Conventional contactors are oversized for some power applications in which industrial relays wear quickly and only achieve a short service life. This is where our PWR miniature contactors are used. Thanks to switching currents of up to 30 A, a double-break contact and a significantly larger contact gap, they are able to switch industrial loads reliably.



Visit our website for more information  
[www.weidmueller.com/pw](http://www.weidmueller.com/pw)

## Power solid-state relays

Switch high AC loads up to 30 A completely wear-free and noiseless

### C

Due to their high shock and vibration resistance, the large switching current and the option of simple fusing, our power solid-state relays outperform by far any electromagnetic relays, especially in the process industry.

The compact modules need just a low control power at the input, have fast response times and operate noiseless. For special applications, a variant with a monitoring circuit enables current and temperature monitoring.

Our new power solid state relays are ideally suited for a multitude of diverse tasks: switching of pipe heaters and infrared heaters, or permanent current monitoring.

**1- and 3-phase, 30 A AC and 15 A DC**

Our portfolio includes three solid-phase solid-state contactors for AC switching voltages up to 600 V AC, 30 A AC, one for DC switching voltages up to 1000 V DC, 15 A DC and a triple-phase solution for AC switching voltages up to 600 V AC, 20 A AC.

**Ready to use with integrated heat sink**

Thanks to the integrated heat sink with mounting rail base, our solid-state contactors are quick and easy to install. No complicated calculation and selection of the heat sink and no drilling required.

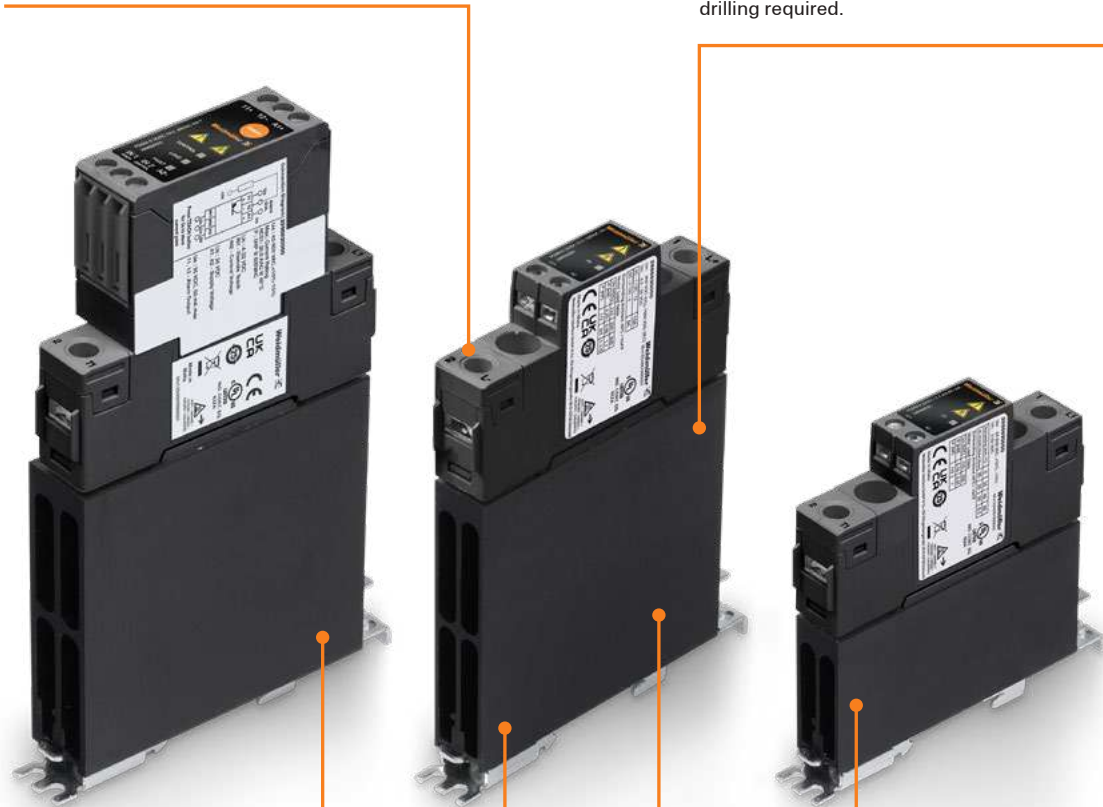
**Special version with monitoring circuit**

Another special variant includes an integrated monitoring circuit for monitoring the switching current. Partial load failures and defective semiconductors are easily recognisable. The temperature of the power semiconductor is also monitored.

**Spacesaving installation**

The single-phase solid-state relays with a width from 17.8 mm (single-phase) save space and simplify wiring. They have the same width as miniature circuit-breakers and can be installed in line under the miniature circuit-breakers.

**Special version for high DC voltages**

The special version with DC output enables the switching of high DC voltages up to 1000 V DC. This means that even large inductive DC loads can be switched reliably and silently where normal power relays already fail.

**DC industry ready**

Thanks to the switching voltage of up to 1000 V DC, the special version with DC output is also suitable for use in the DC industry segment.

**PSSR - 1-phase**

- Single-phase load circuit: 24...230 V AC / 20 A
- Ready-to-use: snap on - connect - ready
- Zero-cross switch
- Noiseless, wear-free switching

**PSSRN K 24VDC 1Z K 240VAC 20A**



**Technical data**

Control side	
Rated control voltage	3...32 V DC
Power rating	
Pull-in/drop-out voltage, typ.	3 V / 1 V DC
Input frequency	
Status indicator	Green LED
Protective circuit	Reverse polarity protection
Load side	
Solid-state type	Thyristor (zero-cross switch)
Rated switching voltage	24...230 V AC +10% -15%
Continuous current	20 A
Min. switching current	150 mA
Max. switching current	20 A
Voltage drop at max. load	
Leakage current	<3 mA
Short-circuit-proof / Protective circuit, load side	No / Integrated varistor, RC element
Switch-on delay / Switch-off delay	≤ 10 ms / ≤ 10 ms
Output voltage frequency range	45...65 Hz
Pulse load, max. current	325 A (10 ms, non-recurrent)
Load category	AC 51, AC 53
Load limit integral (I²t) <10 ms	525 A²s
General data	
Ambient temperature (operational)	-40 °C...80 °C
Storage temperature	-40 °C...100 °C
Humidity	95% relative humidity, non-condensing @ 40°C
Approvals	CE, cULus
Standards	
Insulation coordinates	
Impulse withstand voltage	6 kV (1.2/50 µs)
Clearance and creepage distances for control side - load side	
Overvoltage category	III
Pollution degree	2
Dimensions	
Clamping range (rated / min. / max.) control side	/ 0.75 / 2.5
Clamping range (rated / min. / max.) load side	/ 2.5 / 6
Depth x width x height	103 / 17.8 / 110 mm
Note	

**Ordering data**

	Screw connection
--	------------------

Type	Qty.	Order No.
PSSRN K 24VDC 1Z K 240VAC 20A	1	2986890000

**Note**

Accessories and dimensioned drawings: refer to the Power Solid-state Relay Accessories page.

**Accessories**

<b>Note</b>	
-------------	--

**Current Derating Curve**

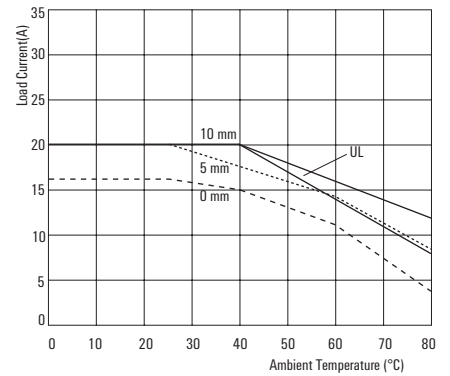

**Derating curve**

\*If the distance is less than 10 mm, refer to current derating curve. If this is the case it will be derated by 1% per 100 m up to 2000 m.

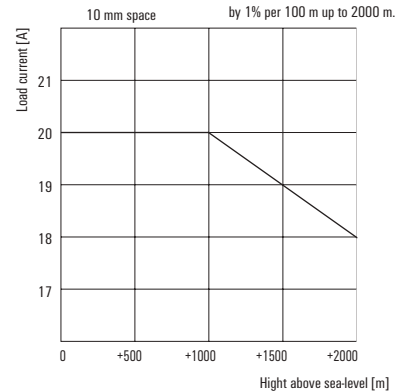

**PSSR - 1-phase**

- Single-phase load circuit: 42...600 V AC / 30 A
- Ready-to-use: snap on - connect - ready
- Zero-cross switch
- Noiseless, wear-free switching

**PSSRN K 24VDC 1Z K 600VAC 30A**



**Technical data**

**Control side**

Rated control voltage  
Power rating  
Pull-in/drop-out voltage, typ.

Input frequency  
Status indicator  
Protective circuit

**Load side**

Solid-state type  
Rated switching voltage  
Continuous current  
Min. switching current  
Max. switching current  
Voltage drop at max. load  
Leakage current  
Short-circuit-proof / Protective circuit, load side  
Switch-on delay / Switch-off delay  
Output voltage frequency range  
Pulse load, max. current  
Load category  
Load limit integral (I<sup>2</sup>t) <10 ms

**General data**

Ambient temperature (operational)  
Storage temperature  
Humidity  
Approvals  
Standards

**Insulation coordinates**

Impulse withstand voltage  
Clearance and creepage distances for control side - load side  
Overvoltage category  
Pollution degree

**Dimensions**

Clamping range (rated / min. / max.) control side  
Clamping range (rated / min. / max.) load side  
Depth x width x height mm

**Note**

4...32 V DC

3.80 V / 1 V DC

Green LED  
Reverse polarity protection

Thyristor (zero-cross switch)  
42...600 V AC +10% -15%  
30 A  
400 mA  
30 A

<3 mA  
No / Integrated varistor, RC element  
≤ 10 ms / ≤ 10 ms

45...65 Hz  
1150 A (10 ms, non-recurrent)  
AC 51, AC 53  
6600 A<sup>2</sup>s

-40 °C...80 °C  
-40 °C...100 °C  
95% relative humidity, non-condensing @ 40°C  
CE; cULus

6 kV (1.2/50 μs)

III  
2

/ 0.75 / 2.5  
/ 2.5 / 6  
103 / 17.8 / 110

**Ordering data**

Screw connection

Type	Qty.	Order No.
PSSRN K 24VDC 1Z K 600VAC 30A	1	2986900000

**Note**

Accessories and dimensioned drawings: refer to the Power Solid-state Relay Accessories page.

**Accessories**

**Note**

**Current Derating Curve**

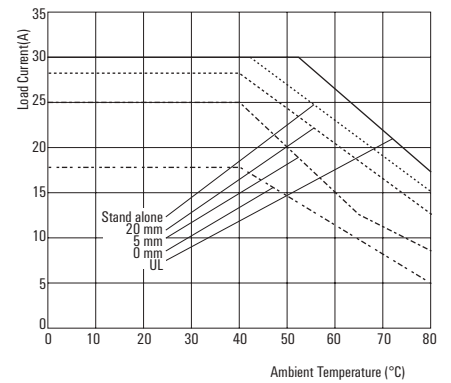

**Derating curve**

\*If the distance is less than 20 mm, refer to current derating curve. If this is the case it will be derated by 1% per 100 m up to 2000 m.

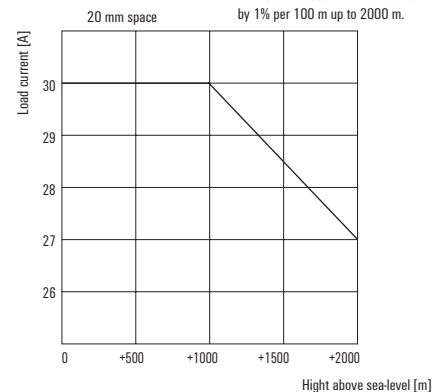

**Power – Power solid-state relays**

**PSSR - 1-phase**

- Single-phase load circuit: 42...600 V AC / 30 A
- Ready-to-use: snap on - connect - ready
- Zero-cross switch
- Noiseless, wear-free switching
- With monitoring module
- High capacity for handling surge currents  
I<sup>2</sup>t = 6000 A<sup>2</sup>s (10 ms)
- Fusing with B circuit breaker possible

**PSSRN S 24VDC 1M K 600VAC 30A T**



**Technical data**

**Control side**

Rated control voltage  
Power rating  
Pull-in/drop-out voltage, typ.  
Input frequency  
Status indicator  
Protective circuit

**Load side**

Solid-state type  
Rated switching voltage  
Continuous current  
Min. switching current  
Max. switching current  
Voltage drop at max. load  
Leakage current  
Short-circuit-proof / Protective circuit, load side  
Switch-on delay / Switch-off delay  
Output voltage frequency range  
Pulse load, max. current  
Load category  
Load limit integral (I<sup>2</sup>t) <10 ms

**General data**

Ambient temperature (operational)  
Storage temperature  
Humidity  
Approvals  
Standards

**Insulation coordinates**

Impulse withstand voltage  
Clearance and creepage distances for control side - load side  
Overvoltage category  
Pollution degree

**Dimensions**

Clamping range (rated / min. / max.) control side  
Clamping range (rated / min. / max.) load side  
Depth x width x height mm

**Note**

4...32 V DC

3.8 V / 1 V DC

Green LED  
Reverse polarity protection

Thyristor (zero-cross switch)

42...600 V AC +10% -15%

30 A

1.2 A

30 A

≤20 V

<3 mA

No / Integrated varistor

≤ 10 ms / ≤ 10 ms

45...65 Hz

1150 A (10 ms, non-recurrent)

AC 51

6600 A<sup>2</sup>s

-25 °C...70 °C

-40 °C...100 °C

95% relative humidity, non-condensing @ 40°C

CE: cULus

6 kV (1.2/50 μs)

III

2

/ 1 / 2.5

/ 2.5 / 6

167.5 / 22.5 / 110

**Ordering data**

Screw connection

Type	Qty.	Order No.
PSSRN S 24VDC 1M K 600VAC 30A T	1	2986920000

**Note**

Accessories and dimensioned drawings: refer to the Power Solid-state Relay Accessories page.

**Accessories**

**Note**

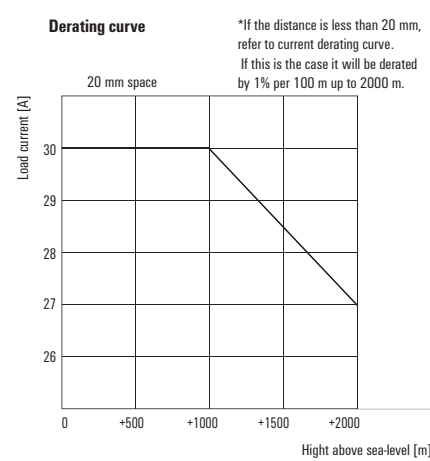
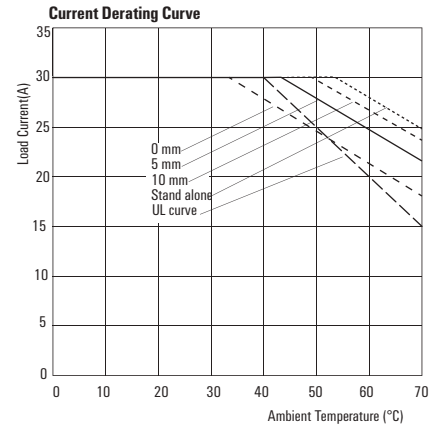

**PSSR - 1-phase**

- Load circuit 1-phase 20.4...1000 V DC / 15 A
- Ready-to-use: snap on-connect-ready
- For switching high DC loads up to 1000 V
- Noiseless, wear-free switching

**PSSRN K 24VDC 1D K 1000VDC 15A**



**Technical data**

**Control side**

Rated control voltage  
Power rating  
Pull-in/drop-out voltage, typ.  
Input frequency  
Status indicator  
Protective circuit

**Load side**

Solid-state type  
Rated switching voltage  
Continuous current  
Min. switching current  
Max. switching current  
Voltage drop at max. load  
Leakage current  
Short-circuit-proof / Protective circuit, load side  
Switch-on delay / Switch-off delay  
Output voltage frequency range  
Pulse load, max. current  
Load category  
Load limit integral (I<sup>2</sup>t) <10 ms

**General data**

Ambient temperature (operational)  
Storage temperature  
Humidity  
Approvals  
Standards

**Insulation coordinates**

Impulse withstand voltage  
Clearance and creepage distances for control side - load side  
Overvoltage category  
Pollution degree

**Dimensions**

Clamping range (rated / min. / max.) control side  
Clamping range (rated / min. / max.) load side  
Depth x width x height mm

**Note**

4.5...32 V DC

4 V / 1 V DC

Green LED

IGBT  
20.4...1000 V DC (IEC)

15 A

20 mA

15 A

≤ 1.6 V

<1.5 mA

No / Integrated free-wheel diode

0.1 ms / 250 μs

200 A (10 μs, non-recurrent)

DC1, DC 3, DC 5

-40 °C...80 °C

-40 °C...100 °C

95% relative humidity, non-condensing @ 40°C

CE: cULus

6 kV (1.2/50 μs)

III

2

/ 0.75 / 2.5

/ 2.5 / 6

140.5 / 17.8 / 110

**Ordering data**

Screw connection

Type	Qty.	Order No.
PSSRN K 24VDC 1D K 1000VDC 15A	1	2986930000

**Note**

Accessories and dimensioned drawings: refer to the Power Solid-state Relay Accessories page.

**Accessories**

**Note**

**Derating Curve**

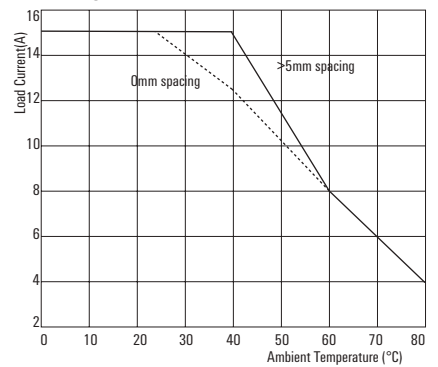

**Derating curve**

\*If the distance is less than 10 mm, refer to current derating curve. If this is the case it will be derated by 1% per 100 m up to 2000 m.

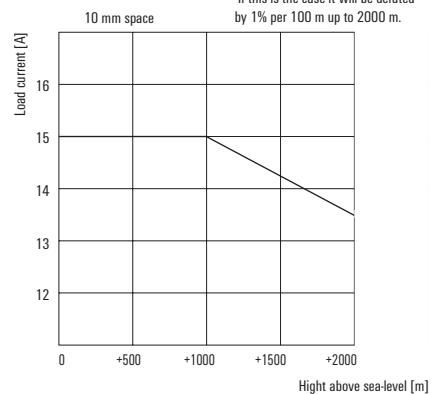

**PSSR - 3-phase**

- Load circuit 3-phase 42...600 V AC / 24 A
- Ready-to-use: snap on-connect-ready
- Noiseless, wear-free switching
- Wear-free & silent switching

**PSSRN K 24VDC 3Z K 600VAC 20A**



**Technical data**

**Control side**

Rated control voltage  
 Power rating  
 Pull-in/drop-out voltage, typ.  
 Input frequency  
 Status indicator  
 Protective circuit

**Load side**

Solid-state type  
 Rated switching voltage  
 Continuous current  
 Min. switching current  
 Max. switching current  
 Voltage drop at max. load  
 Leakage current  
 Short-circuit-proof / Protective circuit, load side  
 Switch-on delay / Switch-off delay  
 Output voltage frequency range  
 Pulse load, max. current  
 Load category  
 Load limit integral (I²t) <10 ms

**General data**

Ambient temperature (operational)  
 Storage temperature  
 Humidity  
 Approvals  
 Standards

**Insulation coordinates**

Impulse withstand voltage  
 Clearance and creepage distances for control side - load side  
 Overvoltage category  
 Pollution degree

**Dimensions**

Clamping range (rated / min. / max.) control side  
 Clamping range (rated / min. / max.) load side  
 Depth x width x height mm

**Note**

5...32 V DC

4.80 V / 1 V DC

Green LED

Thyristor (zero-cross switch)

42...600 V AC +10% -15%

20 A

250 mA

25 A

5 mA

No / Integrated varistor

≤ 10 ms / ≤ 10 ms

45...65 Hz

600 A (10 ms, non-recurrent)

AC 51, AC 53

1800 A²s

-40 °C...80 °C

-40 °C...100 °C

95% relative humidity, non-condensing @ 40°C

CE; cULus

6 kV (1.2/50 µs)

III

2

/ 0.75 / 2.5

/ 2.5 / 6

102.5 / 54 / 110

**Ordering data**

Screw connection

Type	Qty.	Order No.
PSSRN K 24VDC 3Z K 600VAC 20A	1	2986910000

**Note**

Accessories and dimensioned drawings: refer to the Power Solid-state Relay Accessories page.

**Accessories**

**Note**

**Derating Curve**

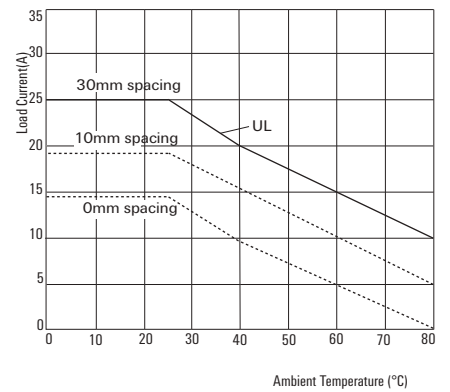

**Derating curve**

\*If the distance is less than 20 mm, refer to current derating curve. If this is the case it will be derated by 1% per 100 m up to 2000 m.

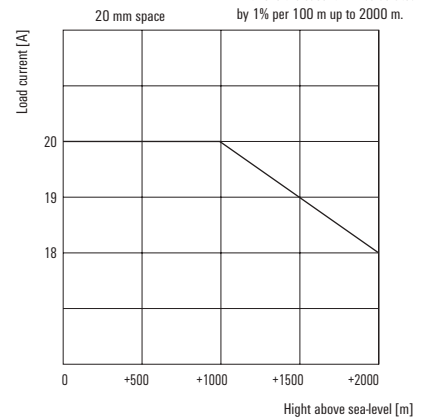

Dimensioned drawing for PSSR

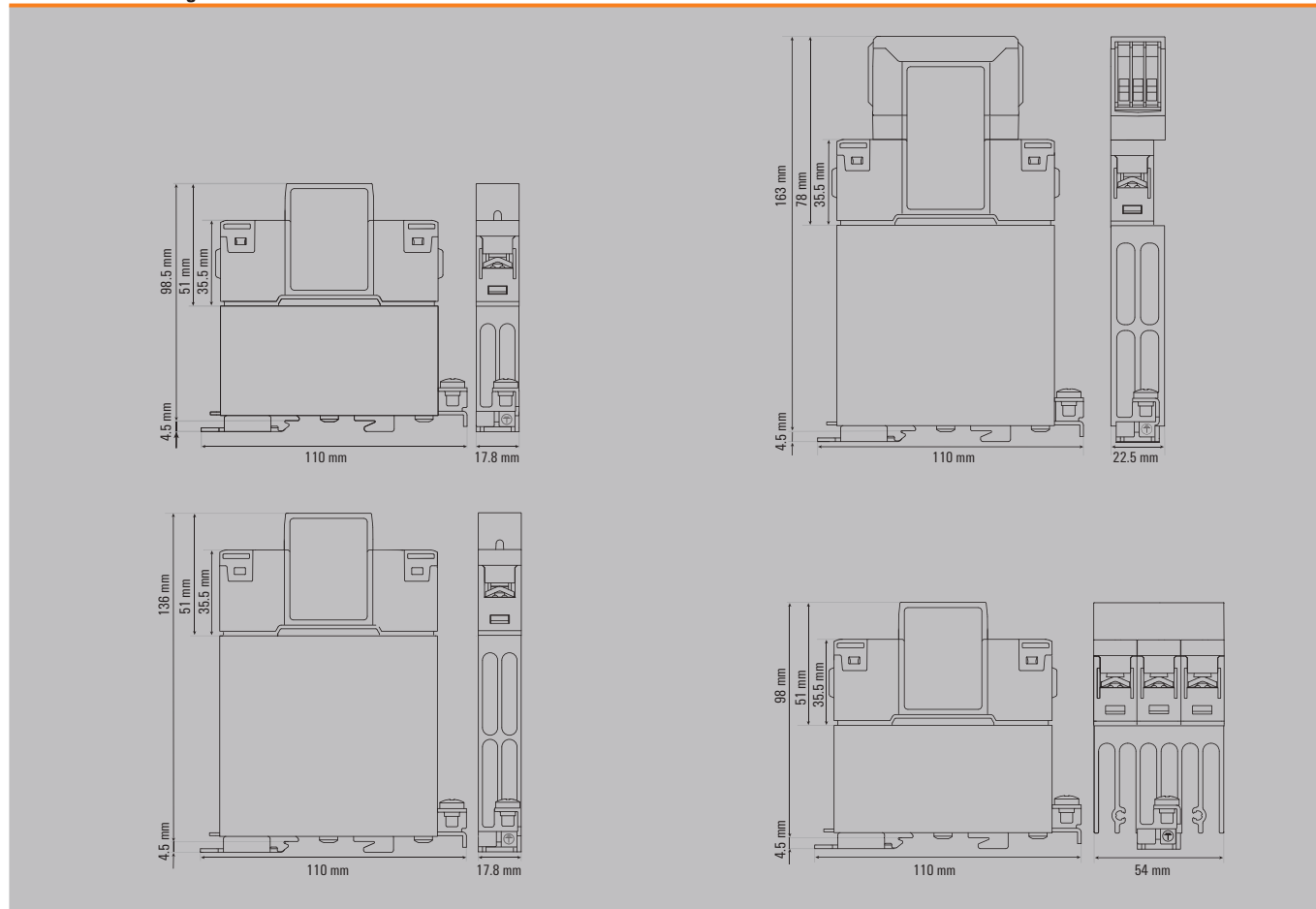

Application range

C

Uninsulated screwdriver

Weidmüller SoftFinish screwdriver for general uses. Blade made from fully hardened, high-alloy chromium-vanadium-molybdenum steel, matt chrome finish.

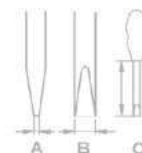

Screwdriver for the connections on the input side

SD S

Slotted screwdriver with rounded blade SD DIN 5265, ISO 2380/2, output to DIN 5264, ISO 2380/1. ChromTop tip, SoftFinish® grip

Type	Size / AF	A	B	C	Order No.
SDS 0.6X3.5X100		0.6	3.5	100	2749340000



Screwdriver for the connections on the output side

SDK PZ

Crosshead screwdriver, Pozidriv, SDK PZ DIN 5262, ISO 8764/2-PZ, output to ISO 8764/1-PZ, ChromTop tip, SoftFinish® grip

SDK PZ2 X 100	2			100	2749450000
---------------	---	--	--	-----	------------



**PWR high-power relay**

**1 NO AC/DC coil**

- Max. load current: 30 A



**Circuit diagram**

1NO

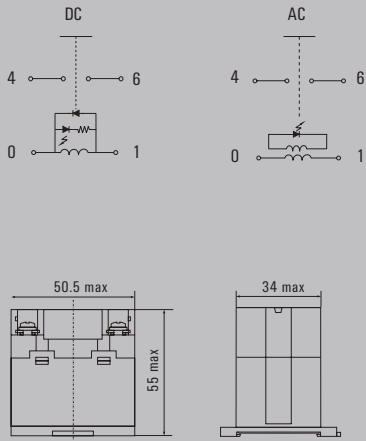

**Technical data**

Load side	
Rated switching voltage / Continuous current	277 V AC / 30 A
Max. switching voltage, AC	250 V
Inrush current	150 A / 50 ms
Min. switching power	100 mA @ 12 V
Contact type	1 NO contact (AgSnO)
Mechanical service life	
Max. switching frequency at rated load	0.1 Hz
General data	
Ambient temperature (operational)	-25 °C...55 °C
Storage temperature	-25 °C...55 °C
Humidity	35...85 % rel. humidity, no condensation
Approvals	CE; cURus; UKCA
Insulation coordinates	
Rated voltage	250 V
Impulse withstand voltage	6 kV (1.2/50 µs)
Dielectric strength for control side - load side	4 kV <sub>eff</sub> / 1 min
Dielectric strength of neighbouring contacts	
Dielectric strength to mounting rail	
Clearance and creepage distances for control side - load side	≥ 5.5 mm
Overvoltage category	III
Pollution degree	3

Dimensions	Screw connection
Depth x width x height	mm 55 / 50.5 / 34

**Note**

**Applications**

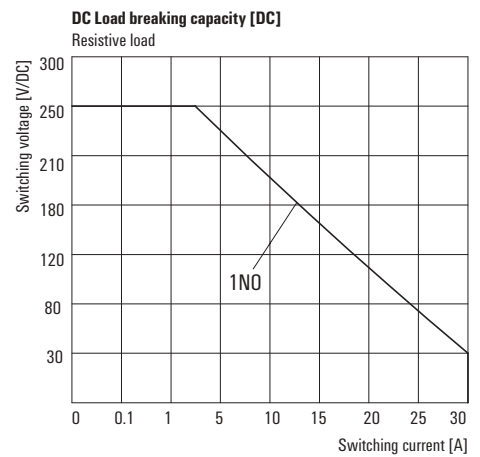
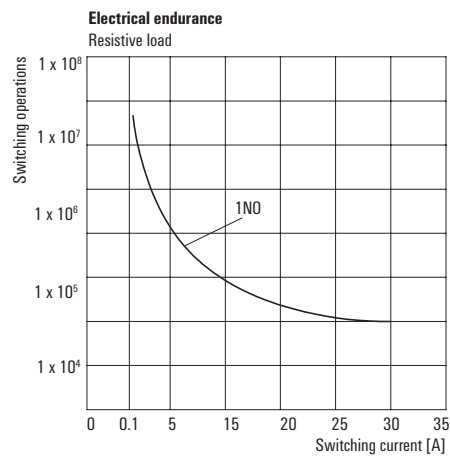
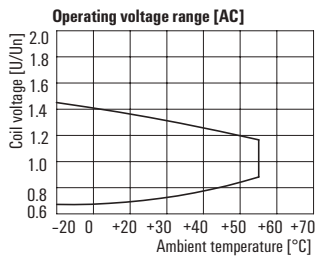
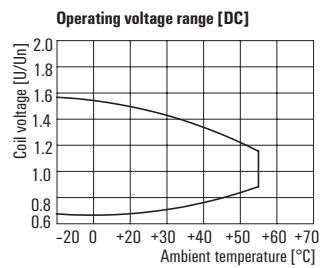

**PWR high-power relay**  
**1 NO AC/DC coil**

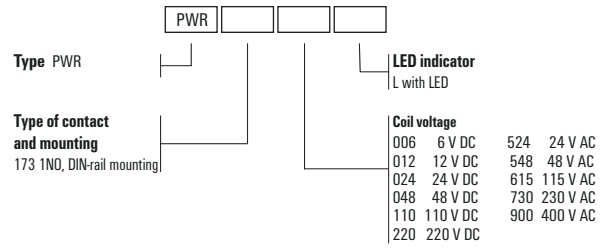

**Ordering data**

	12 V DC 1 NO	24 V DC 1 NO	48 V DC 1 NO	110 V DC 1 NO	220 V DC 1 NO
<b>Control side</b>					
Rated control voltage	12 V DC	24 V DC	48 V DC	110 V DC	220 V DC
Rated current AC / DC	/ 160 mA	/ 79.2 mA	/ 39.3 mA	/ 17.3 mA	/ 8.7 mA
Power rating	1.9 W	1.9 W	1.9 W	1.9 W	1.9 W
Status indicator	Green LED	Green LED	Green LED	Green LED	Green LED

Ordering data						
Terminal rail mounting	Type	PWR173012L	PWR173024L	PWR173048L	PWR173110L	PWR173220L
Order No.		<b>1219470000</b>	<b>1219480000</b>	<b>1219490000</b>	<b>1219510000</b>	<b>1219520000</b>
Type						
Order No.						
<b>Note</b>						

**Ordering data**

	24 V AC 1 NO	48 V AC 1 NO	115 V AC 1 NO	230 V AC 1 NO	380 V AC 1 NO
<b>Control side</b>					
Rated control voltage	24 V AC	48 V AC	115 V AC	230 V AC	380 V AC
Rated current AC / DC	87.3 mA /	43.6 mA /	22.1 mA /	11 mA /	6.1 mA /
Power rating	2.5 VA	2.5 VA	2.5 VA	2.5 VA	2.5 VA
Status indicator	Green LED	Green LED	Green LED	Green LED	Green LED

Ordering data						
Terminal rail mounting	Type	PWR173524L	PWR173548L	PWR173615L	PWR173730L	PWR173880L
Order No.		<b>1219090000</b>	<b>1219120000</b>	<b>1219130000</b>	<b>1219140000</b>	<b>1219150000</b>
Type						
Order No.						
<b>Note</b>						

PWR high-power relay

2 NO AC/DC coil

- Max. load current: 25 A



Circuit diagram

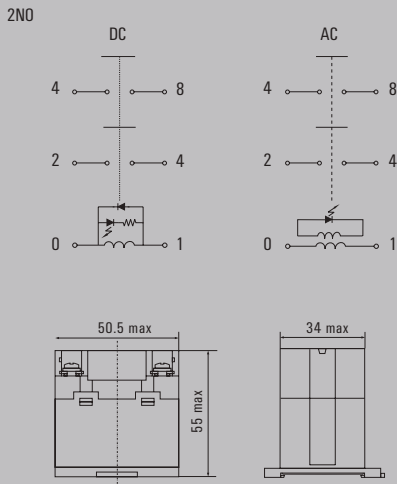

Technical data

Load side	
Rated switching voltage / Continuous current	277 V AC / 25 A
Max. switching voltage, AC	
Inrush current	120 A / 50 ms
Min. switching power	100 mA @ 12 V
Contact type	2 NO contact (AgSnO)
Mechanical service life	
Max. switching frequency at rated load	0.1 Hz
General data	
Ambient temperature (operational)	-25 °C...55 °C
Storage temperature	-25 °C...55 °C
Humidity	35...85 % rel. humidity, no condensation
Approvals	CE; cURus; UKCA
Insulation coordinates	
Rated voltage	250 V
Impulse withstand voltage	6 kV (1.2/50 μs)
Dielectric strength for control side - load side	4 kV <sub>eff</sub> / 1 min
Dielectric strength of neighbouring contacts	2 kV <sub>eff</sub> / 1 min
Dielectric strength to mounting rail	
Clearance and creepage distances for control side - load side	≥ 5.5 mm
Overvoltage category	III
Pollution degree	3

Dimensions	Screw connection
Depth x width x height	mm 55 / 50.5 / 34

Note

Applications

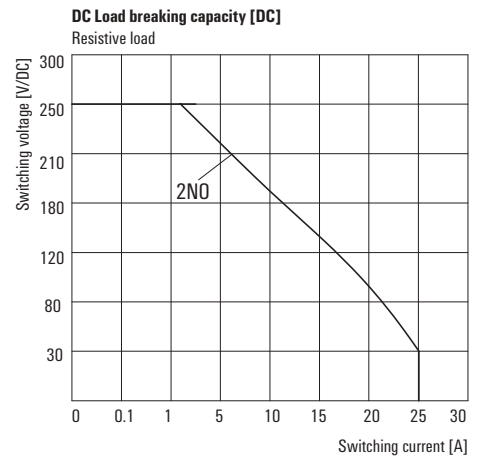
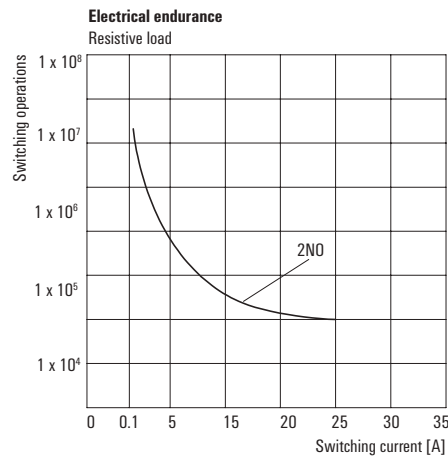
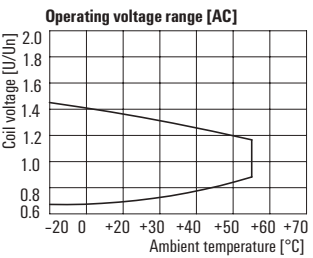
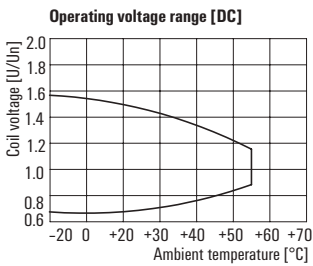

**PWR high-power relay**  
**2 NO AC/DC coil**

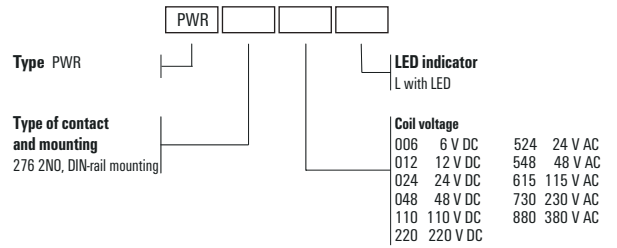

**Ordering data**

	12 V DC 2 NO	24 V DC 2 NO	48 V DC 2 NO	110 V DC 2 NO	220 V DC 2 NO
<b>Control side</b>					
Rated control voltage	12 V DC	24 V DC	48 V DC	110 V DC	220 V DC
Rated current AC / DC	/ 160 mA	/ 79.2 mA	/ 39.3 mA	/ 17.3 mA	/ 8.7 mA
Power rating	1.9 W	1.9 W	1.9 W	1.9 W	1.9 W
Status indicator	Green LED	Green LED	Green LED	Green LED	Green LED

Ordering data					
Terminal rail mounting					
Type	PWR276012L	PWR276024L	PWR276048L	PWR276110L	PWR276220L
Order No.	<b>1219540000</b>	<b>1219550000</b>	<b>1219560000</b>	<b>1219570000</b>	<b>1219580000</b>
Type					
Order No.					
<b>Note</b>					

**Ordering data**

	24 V AC 2 NO	48 V AC 2 NO	115 V AC 2 NO	230 V AC 2 NO	380 V AC 2 NO
<b>Control side</b>					
Rated control voltage	24 V AC	48 V AC	115 V AC	230 V AC	380 V AC
Rated current AC / DC	87.3 mA /	43.6 mA /	22.1 mA /	11 mA /	6.1 mA /
Power rating	2.5 VA	2.5 VA	2.5 VA	2.5 VA	2.5 VA
Status indicator	Green LED	Green LED	Green LED	Green LED	Green LED

Ordering data					
Terminal rail mounting					
Type	PWR276524L	PWR276548L	PWR276615L	PWR276730L	PWR276880L
Order No.	<b>1219160000</b>	<b>1219170000</b>	<b>1219180000</b>	<b>1219190000</b>	<b>1219220000</b>
Type					
Order No.					
<b>Note</b>					

**Accessories**

**TERMOPTO - Accessories**

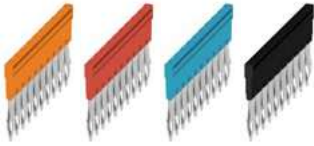

**Plug-in cross-connection**

Type	No. of poles	Qty.	Order No.
<b>orange</b>			
ZQV 4N/2	2	60	1527930000
ZQV 4N/3	3	60	1527940000
ZQV 4N/4	4	60	1527970000
ZQV 4N/10	10	20	1528090000
ZQV 4N/20	20	20	2883800000
<b>red</b>			
ZQV 4N/2 RD	2	60	2460450000
ZQV 4N/3 RD	3	60	2460810000
ZQV 4N/4 RD	4	60	2460800000
ZQV 4N/10 RD	10	20	2460740000
<b>blue</b>			
ZQV 4N/2 BL	2	60	1528040000
ZQV 4N/3 BL	3	60	1528080000
ZQV 4N/4 BL	4	60	1528120000
ZQV 4N/10 BL	10	20	1528230000
<b>black</b>			
ZQV 4N/2 BK	2	60	2810840000
ZQV 4N/3 BK	3	60	2810880000
ZQV 4N/4 BK	4	60	2810890000
ZQV 4N/10 BK	10	20	2810830000
ZQV 4N/20 BK	20	20	2810870000

**Other accessories**

Type	Qty.	Order No.	
<b>Markers</b>			
WS 12/6	12 x 6 mm	600	1609900000
<b>Screwdriver</b>			
SDS 0.6x3.5x100	1	2749340000	

**Screwdriver - blade shape**

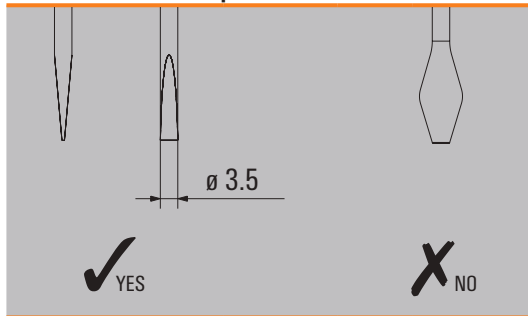

**General data - TERMOPTO**

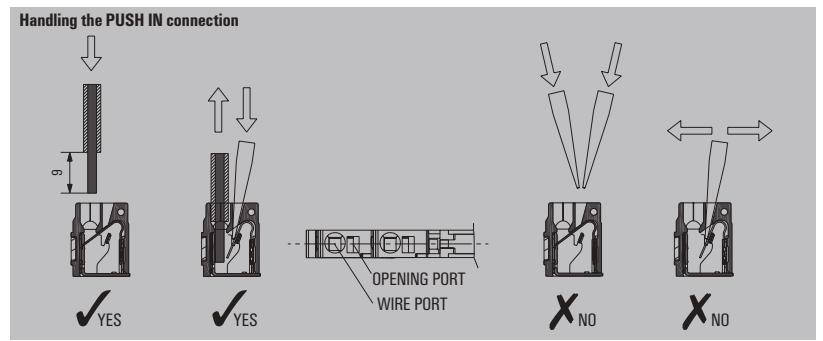

**Technical data**

Conductor		PUSH IN connection	Screw-connection
Solid H07V-U	mm <sup>2</sup>	0.5...1.5	0.5...2.5
Stranded H07V-K	mm <sup>2</sup>	0.5...1.5	0.5...2.5
"f" with wire end ferrules to DIN 46228-1	mm <sup>2</sup>	0.5...1.5	0.5...1.5
"f" with wire end ferrules with plastic collar	mm <sup>2</sup>	0.5...1.5	0.5...1.5
Max. clamping range	mm <sup>2</sup>	0.13...1.5	0.13...2.5
Plug gauge to IEC 60947-1	Size	A 2	A 3
<b>General technical data</b>			
Nominal torque	Nm	-	0.6
Continuous current for 2-pole cross-connection	A	10	10
Continuous current for multi-pole cross-connection	A	10	10
Stripping length	mm	10	9
Ingress protection class		IP 20	IP 20
Housing material		Wemid	Wemid
UL94 flammability rating		V-0	V-0
Nominal current	A	6	6
Nominal voltage	V	250	250

**Dimensions**

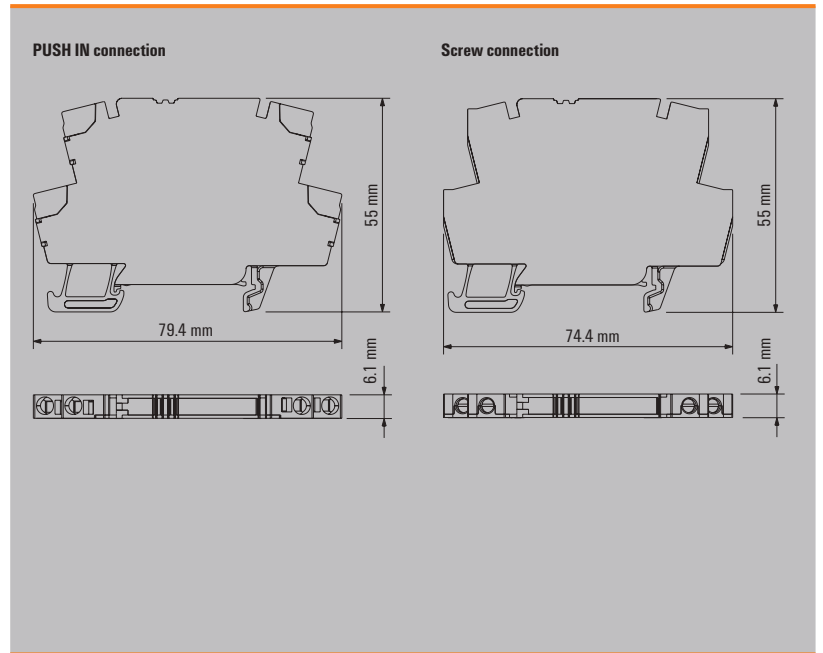

MICROOPTO – Accessories

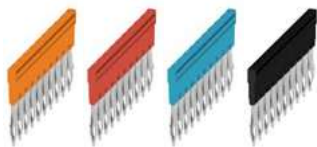

Plug-in cross-connection

Type	No. of poles	Qty.	Order No.
<b>orange</b>			
ZQV 4N/2	2	60	1527930000
ZQV 4N/3	3	60	1527940000
ZQV 4N/4	4	60	1527970000
ZQV 4N/10	10	20	1528090000
ZQV 4N/20	20	20	2883800000
<b>red</b>			
ZQV 4N/2 RD	2	60	2460450000
ZQV 4N/3 RD	3	60	2460810000
ZQV 4N/4 RD	4	60	2460800000
ZQV 4N/10 RD	10	20	2460740000
<b>blue</b>			
ZQV 4N/2 BL	2	60	1528040000
ZQV 4N/3 BL	3	60	1528080000
ZQV 4N/4 BL	4	60	1528120000
ZQV 4N/10 BL	10	20	1528230000
<b>black</b>			
ZQV 4N/2 BK	2	60	2810840000
ZQV 4N/3 BK	3	60	2810880000
ZQV 4N/4 BK	4	60	2810890000
ZQV 4N/10 BK	10	20	2810830000
ZQV 4N/20 BK	20	20	2810870000

Technical data

Conductor	Screw-connection
Solid H07V-U	mm <sup>2</sup> 0.5 ... 4.0
Stranded H07V-K	mm <sup>2</sup> 0.5 ... 2.5
"f" with wire end ferrules to DIN 46228-1	mm <sup>2</sup> 0.5 ... 1.5
"f" with wire end ferrules with plastic collar	mm <sup>2</sup> 0.5 ... 1.5
Max. clamping range	mm <sup>2</sup> 0.13 ... 4.0
Plug gauge to IEC 60947-1	Size A 3
<b>General technical data</b>	
Nominal torque	Nm 0.6
Continuous current for 2-pole cross-connection	A 10
Continuous current for multi-pole cross-connection	A 10
Stripping length	mm 7
Ingress protection class	IP 20
Housing material	Wemid
UL 94 flammability rating	V-0
Nominal current	A 6
Nominal voltage	V 250

Other accessories

Type	Qty.	Order No.
<b>Supply terminals</b>		
MOS SUPPLY	1	8973460000
MOS FEED THROUGH	1	8973450000
<b>Markers</b>		
WS 12/6	12 x 6 mm	600 1609900000
<b>Screwdriver</b>		
SDS 0.6X3.5X100	1	2749340000
<b>Cross-connector for plugging into the clamping point</b>		
QB 75/6.2/15	10	0535200000
<b>Coloured insulating profile for QB</b>		
ISPF QB75 black	10	0526700000
ISPF QB75 blue	10	0526780000
ISPF QB75 red	10	0526760000
<b>End bracket</b>		
WEW 35/2	50	1061210000

Drawings: Supply terminals

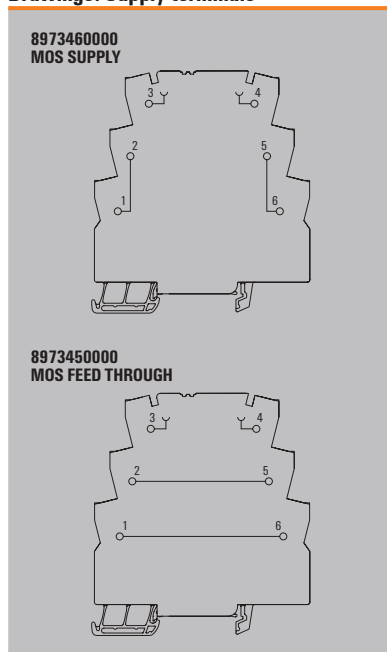

Dimensions

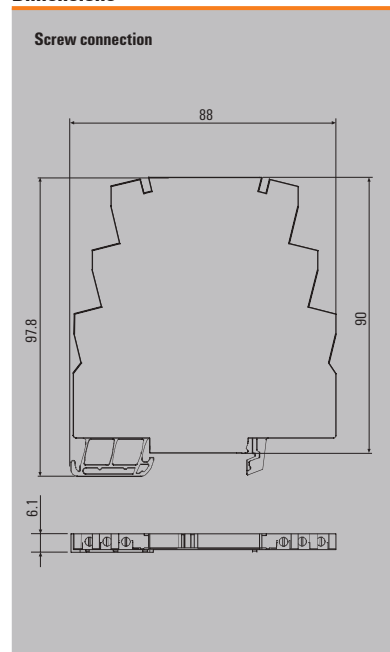



# Service and support

---

<b>Service and support</b>	Service connects - worldwide	V.2
	Engineering services and customised products	V.3
	easyConnect - Your Industrial Service Platform	V.4
	Support Center	V.6
	Additional support services	V.7
	Weidmüller Configurator: intuitive, uncomplicated & fast digital engineering	V.8
	Your digital ordering options at Weidmüller	V.10

---

# Our expertise for your requirements

## Service connects – worldwide



Automation technology functions are becoming more complex in a globally-oriented world facing ambitious targets in terms of energy efficiency and smart production. We are your equal partners for the best connections in Industrial Connectivity.

Our personal support answers all questions reliably and expertly. During planning, installation or operation our service and support offer is your best companion.

In short: Weidmüller's global service combines our expertise with your requirements.

V



**Your way to our service**  
[www.weidmueller.com/service](http://www.weidmueller.com/service)

# Engineering services and customised products

Automation engineering and connectivity consulting belongs to our services as well as assembly of engineered products. We also support the process from the idea to the product with our Weidmüller Configurator and the Configure-to-Order process.



## Consulting and engineering

The challenge for you is reducing costs and increasing efficiency. This requires intelligent, individual solutions. Whether it is modified products, pre-fitted mounting rails or complete small cabinets – our application centres provide a highly qualified custom-made engineering and production service.



## Connectivity Consulting

Increase your competitiveness - supported by our experts. Our drive is to optimise your competitiveness. That's why our team of experts supports you in significantly increasing your efficiency in electrical machine design and control cabinet construction. With proven products and services from the Weidmüller portfolio – and with the experience gained from over 300 projects worldwide.



## Assembled terminal rails - Flexibly designed to suit your requirements

Your processes in panel building have to be fast, flexible and productive. This is the only way you can cut your costs and increase efficiency. Depending on the application in question, you will have different requirements with respect to the engineering service, delivery speed and flexibility to be provided.



## Modified and assembled enclosures - Competitive advantages included

To compete internationally, your plants need to satisfy high standards of safety, quality and performance. The smart combination of consultation, application expertise and industry know-how is our key to finding a custom-fit solution for your application. Reduce costs and increase efficiency.



## Fast Delivery Service - Your ideas deserve a quick realisation

Obtain offers 24/7 and within minutes, including directly orderable article numbers with our Fast Delivery Service. The Weidmüller Configurator (WMC) for planning and configuration is key for consistent processes. Dispatch your orders in 5 days. Assemble individual terminal strips and enclosures from batch size 1!

# Your ticket to the world of digital service

## easyConnect – Your Industrial Service Platform



Our cloud-based platform is your ticket to the world of digital services from Weidmüller, and the intuitive and future-proof tool for your way to the Industrial IoT. Realise your use cases easily, consistently and without any relevant prior knowledge, thanks to the perfect interaction of platform, devices and diverse software services.

As an open, modular and perfectly integrable system, the platform is your enabler for a wide range of use cases. Increase your efficiency and unleash your full innovation potential with easyConnect.

V



**Interested in using easyConnect?**

Learn how to get started with easyConnect step-by-step.

[www.weidmueller.com/easyconnect](http://www.weidmueller.com/easyconnect)

## Why should you use easyConnect?

- You want to enter your digital transformation step-by-step?
- You want to make the step into Industrial IOT, but have no or little IT expertise?
- You want to use your digital data for smart & scalable services?
- You want to offer digital services (such as customised dashboard) to your customers?
- You want to improve your service offering and efficiency, e.g. through remote access?
- You feel Weidmüller's digital services are interesting, but you have „your cloud“ already?



Weidmüller comes up with the solution: easyConnect, the new digitalisation platform. It bundles Weidmüller's digital services at one place in the cloud and connects them with various Weidmüller devices.

With easyConnect you start digitalising your application step-by-step without ballast in a secure way.

## The following services are initially available on easyConnect:



### Device management

Adding and managing cloud-connected devices is typically the first step in any Industrial IoT use case.

### Asset management

The asset management service is a modelling tool that allows users to model their assets and processes and link them to relevant time series data.

### Remote access (u-link)

u-link guarantees a quick and secure access to machines and plants while also allowing for efficient management.

### Data visualisation

easyConnect data visualisation services enable users to view, monitor and display live and historical data.

### AutoML

With Weidmüller Industrial AutoML, you can optimize operations, increase product quality and develop new business models by benefiting from advanced analytics.

## Expand the possibilities of our products

Our Support Center provides you with comprehensive, clear and personal assistance



Receive fast and intuitive support to get the most out of our products in your application. In our new Support Center you can search or navigate to the many application notes, product information, video tutorials or software downloads of our products.

- **Everything at a glance** – One central support hub, where all relevant information is available
- **Powerful search** – Provides filter functions for various types of information and products
- **Different views and navigations** – Content provided in views product information, engineering support or software downloads
- **More than 170,000 downloads** – Application notes, video tutorials, templates and examples, user documentation, engineering data, ...
- **Personal contact** – Direct access to your personal technical contact in your country



Explore the world of our new Support Center  
[support.weidmueller.com](https://support.weidmueller.com)

## Additional support services



### Training and Webinars

Stay tuned in a world that is accelerating. In our entertaining interactive webinars, we offer you the opportunity to learn about new products and technology topics and to interact with our experts.



### Repairs and replacement parts

We offer repair and components for our Workplace Solutions as well as assistance for other Weidmüller products. Find out how our experts can help you with your repair request.



### Security advisory board

Our Product Security Incident Response Team (PSIRT) continuously informs you about possible security-related vulnerabilities of our products.



### Engineering data

For the quick integration of our products into your design, there are a lot of digital product data for engineering systems like EPLAN, Zuken E3.series, WSCAD and many others available for download.



### Product change notifications

Technical modifications of our products always available online.



### Technical product catalogues

Technical data for our entire program in Industrial Connectivity for download in PDF-format.

## From the idea to the finished solution

# Weidmüller Configurator: intuitive, uncomplicated & fast digital engineering

Digital engineering can be so easy – with the Weidmüller Configurator!

It's a **free to use** software application to easily configure industrial solutions. It features more than **12,000 articles** from multiple product families including rail-mounted components, industrial and ex-certified enclosures, Heavy Duty Connectors, remote I/O-systems and PCB connectors.

Unleash the full power of digital engineering:

Our application wizards help you choose the right articles.

Place, mark or modify them to your needs and get your solution **visualized in 3D** – what you see is what you get!

Our promise: Speed up your solution planning process by up to 70%!

### Your benefits:

- **Proven configuration designs in real 3D:** The plausibility and collision check with the complete digital documentation ensures that you can rely 100% on your configuration.
- **Seamless E-CAD Roundtrip:** Interfaces enable the simple exchange of product data between the WMC and all common engineering tools, such as Zuken E3 or EPLAN Electric P8.
- **Sample Service & Fast Delivery Service:** to support your design-in process, we offer a **3-day sample service** for many products. Inquire them directly online – for free!  
You want your solution right away? Our **Fast Delivery Service** guarantees delivery of individually assembled terminal strips or enclosures within a few days.

### Get started online now!

The Weidmüller Configurator makes solution planning easy. Visit our website for more information, tutorials and download it for free:



[www.weidmueller.com/wmc](http://www.weidmueller.com/wmc)



or register on [easyconnect.weidmueller.com](http://easyconnect.weidmueller.com) and use it online.



**Wizards:**

Design complete applications within few clicks – even without detailed product knowledge – for signal wiring, load monitoring, instrument transformers, enclosures, remote I/O-systems and many more.

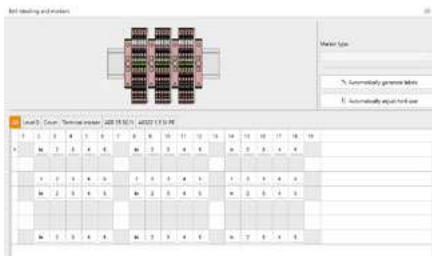

**Assistants:**

Finalize your solutions with supporting assistants to add cross-connectors, markers or colors and verify the faultlessness. Automatic modes save valuable time!



**1-click documentation:**

Get assembly drawings for production – only 1 click. Bill of material – only 1 click. The complete solution documentation including all component data sheets – you’re right, only 1 click!



# Digital ordering options

## Your digital ordering options at Weidmüller

Find and easily select the products you need, with convenient ordering: as your Partner in Industrial Connectivity, we know what counts in purchasing. That is why we offer you a variety of options for ordering products from us and optimising your purchasing processes to meet your individual requirements and your workflow. The choice is yours.

### Order via the Weidmüller eShop

Our eShop offers you access to the complete Weidmüller product range around the clock – directly from a PC, tablet, or smartphone. The intuitive user guidance supports you as you select from over 50,000 products. Technical data, prices, and availabilities are available at any time. The shopping basket with check out function lets you place an order in seconds. Convenient additional functions like CSV upload, order history, reports, or custom order templates make your ordering processes even more efficient.

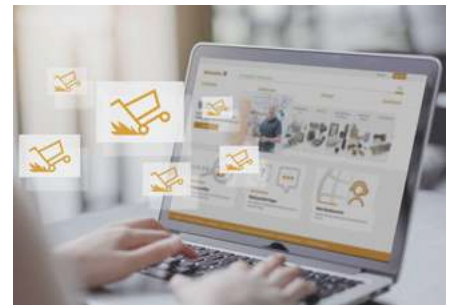

### Order via the OCI interface

The Open Catalogue Interface (OCI) facilitates the exchange of data between your enterprise resource planning system and our eShop. This means that our eShop is integrated into your system via an OCI interface, so you have access to our complete product catalogue from your enterprise resource planning system. You can filter and select products, place them in your shopping basket and place direct orders without changing your software application. The open OCI standard is supported worldwide from a variety of software providers.

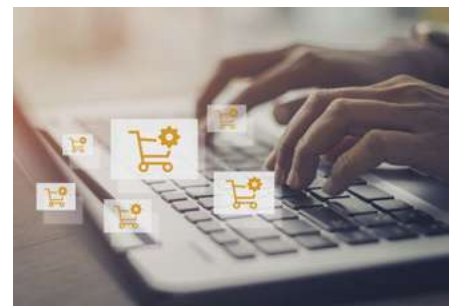

### Order via the EDI interface

Our Electronic Data Interchange (EDI) also offers you the option of ordering our products directly from your enterprise resource planning system. All order data is transmitted automatically to our system and processed immediately. Orders, order confirmations, invoices, and delivery notices are transmitted lightning fast. This helps you make your purchasing processes even more efficient.



We will be glad to advise you on which solutions are suitable for you and how implementation is possible.

**Get in touch with us**

[www.weidmueller.com/digital-order](http://www.weidmueller.com/digital-order)

# Technical appendix/Glossary

<b>Technical appendix/Glossary</b>	Relay modules and solid-state relays - Introduction	W.2
	Relay modules and solid-state relays - Comparison	W.4
	Relay modules - Overview	W.6
	Relay modules - Switching loads	W.7
	Solid-state relays - Overview	W.8
	Solid-state relays - Switching loads	W.10
	Protective circuits for outputs	W.12
	Glossary: Relay modules and Solid-state relays	W.14

# Relay modules and solid-state relays – Introduction

Our relay modules, solid-state relays and additional value added services are hugely beneficial for our customers: space-saving installation, control cabinet optimisation, reduced wiring effort, optimal markability and cost reductions. Supplemented by our complete portfolio, Weidmüller offers everything from a single source. Over the following pages, we would like to explain the world of relay modules and solid-state relays and provide technical explanations of the features in the data sheet.

There are three main applications for relay modules and solid-state relays, which we will explain briefly below:

## Potential isolation

Many applications require that the control circuit is electrically isolated from the load circuit. This primarily protects the control level from interference from the field, such as:

- Interference currents e.g. from earth and ground loops
- Interference pulses e.g. from inductive effects of transients

## Switching amplification/signal adaptation

The separation of the load and control circuits, in conjunction with the associated options for configuring both circuits separately, means that relay modules and solid-state relays are often used for switching amplification and signal conditioning purposes.

This allows the different voltage potentials of signals from the control and load circuits to be aligned.

They are also used to amplify current values that exceed the load capacity of the control unit, e.g. a PLC output.

## Contact multiplication

With applications, it is often necessary to control several load circuits simultaneously with one control signal.

With electromechanical relays, this can be achieved with multi-channel variants, whereby up to four load circuits can be switched simultaneously with one control signal, e.g. using a 4 changeover output.

In addition, multi-channel relays can be used, whereby one of the channels is used to switch the load and another channel is used to return a feedback signal on the switching status of the output to the upstream control unit.



# Relay modules and solid-state relays – Comparison

## Advantages of electromechanical relay modules (EMR)

- AC and DC operation in load circuit possible  
Versatile (advantage as interface between different plant equipment)
- No leakage current in the load circuit  
A semi-conductor does not achieve 100 % isolation
- Low residual voltage in the load circuit  
Low voltage drop
- Significantly lower power loss in the load circuit  
In contrast to the semiconductor in the opto module, there is very little electrical resistance in the contacts of the electromechanical relay, which can lead to a rise in temperature when under load. Therefore, heat sinks are not required.
- Contact multiplication possible  
A single control signal can switch several load circuits
- Control circuit insensitive to voltage peaks  
The switch-on power of the magnetic coil prevents unintentional switch-on due to voltage couplings.

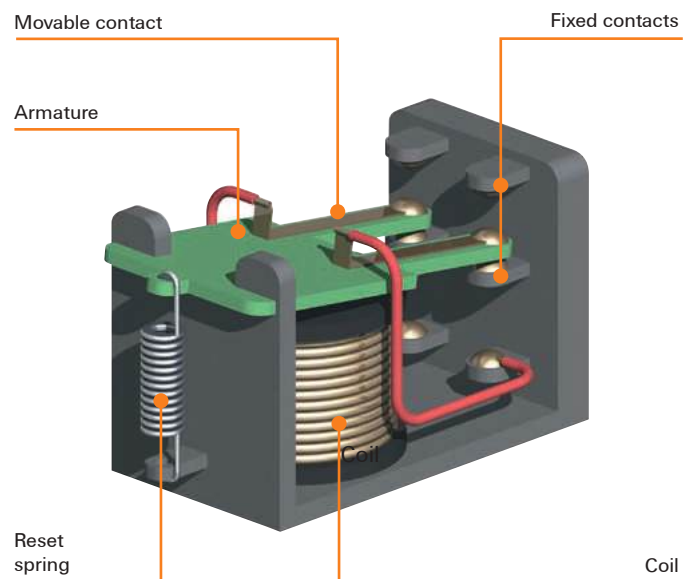

Depending on the requirements, the choice between electromechanical and solid-state relays is made based on the different advantages that the different versions offer:

### Advantages of solid-state relays (SSR)

- Longer service life and increased reliability  
No moving parts or wear on the contacts
- Small dimensions  
Saves space on the PCB and mounting rail
- Low control power  
An LED is activated - no mechanical parts are moved
- Fast response times  
Fast switching, which allows high frequencies to be achieved
- No contact bounce  
Reduces switching delays
- No switching noise  
Suitable for use in noise-sensitive environments
- Not susceptible to shock and vibration  
Prevents unwanted switching statuses
- No electromagnetic radiation due to switching sparks or coils  
No interference of adjacent assemblies or electronics components

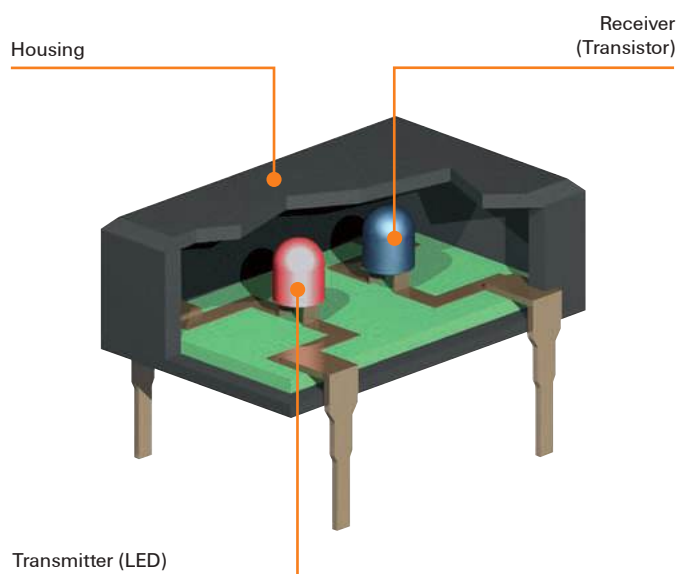

# Relay modules – Overview

## Historical background

The term 'relay' was originally used for a station where stagecoaches were able to change their tired horses for fresh ones. The term 'relay' was given a totally different meaning by the English physicist Charles Wheatstone (1802–1875). In Wheatstone's times, departing trains were advised of by a bell ringing at the next railway station up the line.

This was achieved by connecting a battery in the first station to a bell in the second. However, as the railway stations were generally several kilometres apart the power arriving at the second station was often insufficient to ring the bell. Wheatstone invented a switchgear apparatus that was installed at the second railway station. This continued to function even with low power supply levels. The switchgear apparatus switched a second electrical circuit that actuated the bell. This was the birth of the electromagnetic relay.

## How a relay functions

A relay is an electromagnetic switch comprising of two galvanically isolated circuits. Firstly the control circuit and secondly the open circuit with the normally open contact. As soon as the control circuit is energised, the coil creates a magnetic field in the core/yoke and attracts the armature. The actuator now actuates the switch at the output, the normally open contact (make contact) closes and the normally closed contact (break contact) opens. When the control circuit is turned off, the magnetic field diminishes and the return spring returns the armature to its initial position. The actuator moves the normally open (make contact) back to its normal position, the normally open contact opens, the normally closed contact (break contact) closes.

A relay therefore offers the option of switching high loads with low power, such as battery voltages, and acting as a switching amplifier. Thanks to the galvanic isolation between input and output, a relay is also suitable for providing isolation in the event of potential differences between the control and operating circuits. If a relay also has several working contacts, it can also be used as a contact multiplier.

## From relay to relay module

There are two alternative methods that make a relay module suitable for use in industrial applications: mounting onto a PCB – in combination with the corresponding assembly techniques and circuitry – or plugging onto a specially designed relay socket.

Generally, the design and rating data determine if a relay module is or is not suitable for a particular application.

For example, relay modules with plugged on relays are only partly suitable for use in applications subjected to heavy vibrations. In this case, relay modules with soldered relays should be preferred. Low, compact designs such as those provided by the RIDERSERIES are utilised in small consumer units where the overall available height is limited. Conversely, the compact design of the TERMSERIES helps to save space in electrical cabinets.

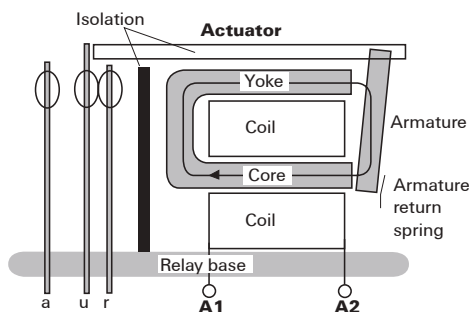

# Relay modules – Switching loads

Electromechanical relays are a varied and cost-effective solution for a wide range of switching processes. They can be used for level and power adaptation and form interfaces between control, signalling and regulating equipment and peripherals. In spite of rising raw material prices, they are still very inexpensive and can be easily integrated into a wide variety of circuit types.

Relay modules from Weidmüller are extremely reliable, durable, and available in many different designs. The diversity of their applications in the various industrial sectors makes it necessary to select a suitable relay for each specific application. The following applies: Due to their design, relay modules are subject to mechanical and electrical wear, which must be taken into account when relay circuits are set up. Electrical consumers always form a mixed load with resistive, capacitive and inductive components, although consumers with a large inductive component are predominantly used in practice. These include contactors, solenoid valves, motors etc. We will take a closer look at these areas of application over the following pages.

## Switching of large AC loads

If large AC loads are switched, the relay can in principle be operated until the specified maximum value of switching voltage, current, or power is reached. However, when switching AC loads, the switching voltage has a much smaller influence on the service life of the relay contact than the switching current. The reason for this is that the arc that occurs when the relay is switched off usually extinguishes automatically at the next zero crossing of the load current. In applications with inductive loads, an effective protective circuit should be provided, as otherwise a significantly reduced service life can be expected.

## Switching of large DC loads

Relays can only switch off relatively small direct currents because the zero crossing for extinguishing the arc is missing here. The maximum direct current value is also dependent on the switching voltage as well as on design conditions such as contact gap and contact opening speed. Corresponding current and voltage values are documented in load limit curves.

With undamped inductive DC loads, these values are lower because the energy stored in the inductance can ignite an arc that carries the current through the open contacts. The resulting arc significantly reduces the service life compared to a resistive load.

An effective contact protection circuit can increase the service life of the contacts by 5 to 10 times compared to inductive loads that are not or unfavorably protected. Type 1N4007 freewheeling diodes are preferably suitable for this purpose.

## Switching of very low power circuits

Low power circuits with values below 30 V/10 mA are mainly used in applications where signals have to be transmitted to control inputs, e.g. to a PLC. Such low loads do not produce a sufficient arc at the contacts.

However, this arc has two important functions: On the one hand, it ensures continuous cleaning of the contacts; on the other hand, it can penetrate non-conductive foreign layers at the contacts. Such foreign layers are usually created by oxidation or sulfidation of common contact materials such as silver (Ag), silver-nickel (AgNi), or silver-tin oxide (AgSnO). The foreign layers can increase the contact resistance after a short time to such an extent that reliable switching of low loads is no longer possible.

For these reasons, gold (Au) is used as the contact material for relays switching small loads. It has proven itself due to its low and constant contact resistance and its resistance to ambient air containing sulphur.

# Solid-state relays – Overview

## Solid-state relays - functionality

Solid-state relays are electronic components (switching elements) that are used to switch a load circuit via a control circuit. First of all, they allow applications with varying power ratings to be switched with relatively minimal switching currents. Secondly, they provide galvanic isolation for the switching and load levels in order to protect components in the event of malfunctions.

In contrast to electromechanical relays, solid-state relays do not have any mechanical parts prone to wear. The core element of a solid-state relay is an optocoupler. In an optocoupler, a light signal is triggered in the control circuit for the switching process via an LED, which causes a light-sensitive semiconductor receiver to close a connected load circuit to switch on the downstream switching amplifier. The transmitter (LED) and receiver (e.g. a phototransistor) of the optocoupler are embedded in a light-conducting plastic material and surrounded by a light-proof casing that protects against outside influences.

Switching amplification is required because optocoupler can only switch comparatively small voltages and currents. The combination of an optocoupler with the switching amplification at the output means that this is now called a solid-state relay.

## The output of a solid-state relay

A voltage range is usually specified for the nominal switching voltage of solid-state relays (e.g. 5 ...48 V DC), which must neither be exceeded nor fallen short of. The same applies to the continuous current. Frequently exceeding this value can lead to premature wear and to destruction of the semiconductor. Short surge voltages (voltage peaks) are eliminated by appropriate protective components such as diodes or varistors. Depending on the output circuit with the appropriate amplifier semiconductor, either AC or DC loads can be connected

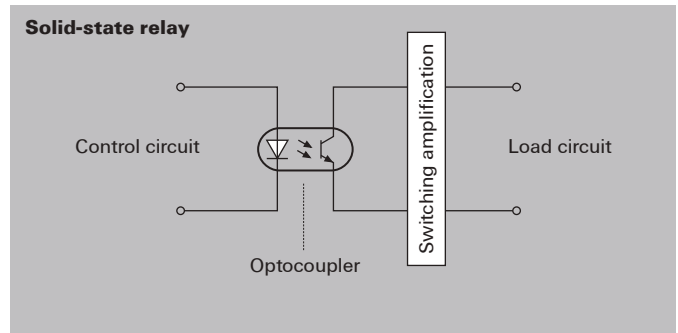
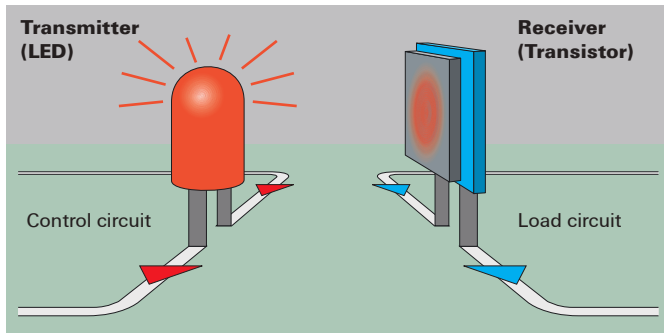

**DC output:**

For the control of DC voltage switching and control devices, a switching amplifier for switching the DC voltage is connected downstream of the optocoupler (bipolar transistor or MOSFET). For DC outputs, the specified polarity must be observed.

2-pole DC outputs can be used as both positive and negative switching outputs unless otherwise specified. The abbreviations NPN (negative switching output) or PNP (positive switching output) are often used for these terms.

With the 3-pole DC connection, the output circuit is provided with an auxiliary voltage which is used for more precise control of the amplifier transistor.

Some applications also require this auxiliary voltage for very fast switching, e.g. of very high frequencies. These outputs are often only positive switching (PNP) or negative switching (NPN) outputs and cannot do both. This is then specified in the instruction sheet or in the data sheet for the respective product.

**Bipolar transistor (for DC outputs)**

For use at low currents ( $\leq 0.5$  A) due to having a higher power loss than MOSFETs. However, cheaper than MOSFETs.

**MOSFET (for DC outputs)**

For use with load currents.

The low contact resistance of the MOSFET generates only very low power loss. Furthermore, a MOSFET output has only very small leakage currents ( $< 10 \mu\text{A}$ ).

**AC output:**

For the control of AC switching and control devices, a switching amplifier for switching the AC voltage is connected downstream of the optocoupler (TRIAC or thyristor).

**Switch-on behaviour of an AC output:**

Most solid state relays with triac or thyristor outputs are zero-voltage switching outputs. This means that once a control signal has been applied at the input, they switch on at the next zero crossing of the AC voltage at the output. However, this behaviour makes these outputs relatively slow in their switch-on behaviour (up to 10 ms delay time at 50 Hz mains frequency of the switched voltage).

To improve this, some AC outputs have an instantaneous switching output. These outputs switch on as soon as possible after a control signal is applied to the input ( $< 0.1$  ms). However, depending on the phase position, this can cause high current peaks when switching on, and can cause the electromagnetic interference emissions in the system to increase.

**Switch-off behaviour of an AC output:**

Semiconductor outputs for AC voltages with triac or thyristor all switch off at the next zero crossing of the output current once the control signal has been removed at the input. As a result, they cannot be used for switching DC voltages.

**Thyristor (for AC outputs)**

For use with load currents.

The function of a thyristor is comparable to that of a one-way diode. For alternating currents, an anti-parallel connection of two thyristors is therefore used.

**Triac (for AC outputs)**

For use with load currents.

A TRIAC combines the functional principle of anti-parallel connected thyristors in a single component.

## Solid-state relays – Switching loads

One particular challenge for the circuits in the load circuit of optocouplers and solid-state relays is posed by the different load types of the possible applications (resistive, inductive, capacitive load). Depending on the application, it is important to be aware of the effects that these loads have on the module being used, and how an appropriate protective device needs to be designed.

In general, it must be ensured that the power loss at the amplifier semiconductor does not exceed a permissible limit value over a long period of time. This would lead to overheating and finally to the destruction of the component.

### Switching resistive loads

Because the current strength in the load circuit and the voltage across the amplifier semiconductor are inversely proportional to each other with resistive loads, these types of loads do not usually pose a problem. In this case, it is sufficient to observe the maximum current and voltage strengths of the modules.

One particular case is the switching of incandescent bulbs. Due to the low cold resistance, overcurrents of 10 to 20 times the operating current can occur when switching on. The components must be designed for these possible overloads, which correspond to the effect with a capacitive load.

### Switching capacitive loads

Capacitive loads occur when there is a capacitor in the load circuit. This acts as a short circuit at the moment of switch-on, causing a high inrush current.

Compared to many other electromechanical relay modules, an amplifier semiconductor is more robust against very short current peaks (< 10 ms) when switching on capacitive loads, because it does not contain any mechanical parts that can weld together. Inrush current peaks that are too high, too steep or too long can still lead to the destruction of the amplifier semiconductor.

### Switching inductive loads

With inductive loads, which are mainly present when coils are used in the load circuit, the problem arises when switching off. Due to the current flow in the coil, a magnetic field builds up which then suddenly collapses and generates a high induction voltage. An amplifier semiconductor needs to be protected from these voltage peaks, otherwise it will be destroyed. Many solid-state relays are equipped with protective suppressor circuits at the output, but these often only provide protection against very small inductive loads. Therefore, when switching inductive loads with solid-state relays, it is highly recommended to have an additional external protective suppressor circuit parallel to the load. This is especially important if inductive loads are to be switched with a frequency faster than 0.5 Hz. When switching inductive loads faster than 5 Hz, specially designed solid-state relays should be used.



# Effective protection of outputs of relay modules and solid-state relays

## Selection criteria for the protective suppressor circuit of inductive loads

In our selection tables we specified the maximum recommended switching currents for inductive loads without protective circuits. If you want to increase the service life of the contacts, you must equip the relay contacts with an effective protective circuit.

The protective circuit on the coil side of a relay module can, for example, be implemented with an integrated or additionally pluggable freewheeling diode. However, this only protects the controlling periphery from the voltage peaks that occur in the coil of the relay module. The relay contact is usually not sufficiently protected against the voltage peaks of the inductive load to be switched, although with optimum dimensioning almost the same values for switching capacity or switching cycles can be achieved as with resistive load.

The largest reduction factor for the service life of a relay contact is the arc generated during switching off inductive loads. It is caused during the switching process by the energy stored in the coil and can destroy the contact through material evaporation and material migration.

With DC voltage and standing arc, the relay can even fail during the first switching cycle. Voltage peaks caused by electric arcs can reach values up to several 1,000 volts.

Protective circuits must be used to suppress the formation of electric arcs.

In the following, we will explain the correct installation of the protective circuit and the effectiveness of the most common types of protective circuit. There are various ways to install an effective protective circuit. For example, the protective circuit can be mounted either parallel to the relay contact or parallel to the load.

However, the protective measure should always apply directly to the source of the fault. Therefore, the protective circuit of the load is preferable to the circuit of the contact.

### Advantages of a protective circuit at the load:

- When the contact is open, the load is still galvanically isolated from the operating voltage
- The switch-off peaks of the load cannot be coupled into the control lines running in parallel

### Free-wheeling diodes

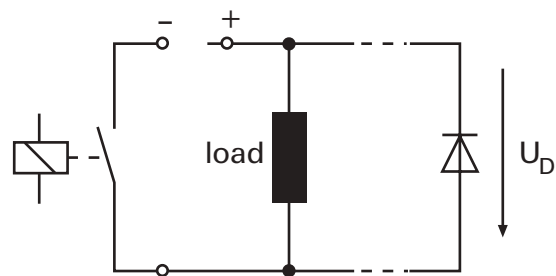

Free-wheeling diodes are used to protect against overvoltages caused by self-induction when an inductive DC voltage load is switched off (e.g. solenoid valves or electric motors). They ensure that the voltage peaks that occur are reduced to the value of the diode forward voltage ( $U_D$ ). However, this leads to a delay in the voltage drop and thus in the switch-off process of the load.

#### Advantage:

- Uncritical dimensioning
- Very positive effect on the service life of the contacts

#### Disadvantage:

- Significantly extended switch off process
- Only suitable for DC voltage

### Varistors

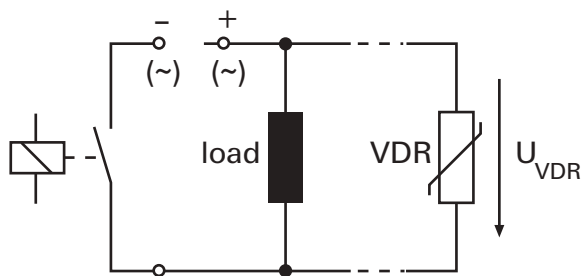

The functional principle of varistors is also based on breakdown voltages ( $U_{VDR}$ ). High energies can be dissipated, but this causes the component to aging. Therefore, the breakdown voltage is reduced over time and the leakage current is increased.

#### Advantage:

- Uncritical dimensioning
- Suitable for DC and AC voltage
- Slightly extended switch off process

#### Disadvantage:

- Complex and expensive with increasing power
- Low effect on the service life of the contact

### RC modules

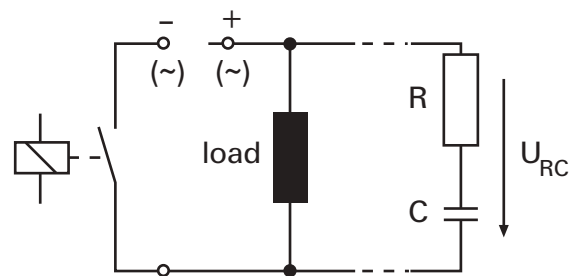

With RC modules, voltage peaks are compensated via a capacitor. Thanks to its special characteristics during charging and discharging the interference pulses are already filtered out during the voltage rise and not only when the breakdown voltage ( $U_{RC}$ ) is reached.

#### Advantage:

- Suitable for DC and AC voltage
- Slightly extended switch off process

#### Disadvantage:

- Exact dimensioning required
- High inrush current
- Low effect on the service life of the contact

## Glossary: Relay modules and Solid-state relays

		for EMR	for SSR
<b>A</b>			
<b>AC switching capacity (resistive), max.</b>	<p>Calculated product for resistive loads from switching current and switching voltage in VA.</p> <p>When switching inductive loads, it is recommended to reduce the switching capacity in order to achieve the longest possible service life.</p> <p>The reduction results from the arc, which is significantly stronger when switching inductive loads than when switching resistive loads.</p>	x	
<b>Approvals and testing marks</b>	<p>The test marks are a way for independent (official or private) approval bodies and testing institutions to confirm compliance with the respective regulations and/or compliance with specified product properties.</p> <p>Note: If any approval-relative technical data is missing from the data sheet, it is available on request.</p> <p>Approvals that we offer for Weidmüller relay modules and solid-state relays, depending on the variant:</p> <p>CSA Canadian Standards Association, Canada</p> <p>DNV-GL Classification society made up of testing bodies Det Norske Veritas and Germanischer Lloyd, Norway</p> <p>TÜV Technischer Überwachungs-Verein [German Technical Inspectorate], Germany</p> <p>cURus Component Recognition Mark from UL (Underwriters Laboratories, Inc.) for the USA and Canada</p> <p>cULus Component Listing Mark from UL (Underwriters Laboratories, Inc.) for the USA and Canada</p> <p>VDE VDE Testing and Certification Institute, Germany (expert reports with production monitoring)</p>	x	x

EMR = Electromechanical relay  
SSR = Solid-state relay

		for EMR	for SSR
<b>B</b>			
<b>B10 and B10d</b>	<p>The B10 value indicates the nominal service life in switching cycles where 90% of a unit of tested relays still work. It is therefore the average number of switching cycles, according to which 10% of relays are to be expected to fail. This value is a statistical expected value that was determined on the basis of lifetime tests. In real applications, the lifetime values differ from the B10 value, as each load is different and the environmental parameters, such as humidity, air pollution, heat, vibrations, radiation, etc., have an influence on the service life. The loads used for the determination of the B10 values are specified in the contactor standard EN 60947 in different categories of use such as z.B. DC-13 or AC-15. However, users must be aware that these loads reflect practice only to a limited extent. Because all DC-13 and AC-15 test loads are highly inductive and operate without a protection circuit. Furthermore, the B10 values are determined at significantly higher switching frequencies than usual in reality. This is done to shorten the test execution time, otherwise tests would take years to deliver a result. An increased switching frequency also represents an increased load on the relay than usual in reality. However, it is almost impossible to compare B10 values of different providers. To compare different relays, the relays would have to be measured in exactly the same test setup. For this reason, the B10 values are often only provided by the manufacturer on request. The B10d indicates the number of switching cycles according to which a dangerous failures occur in 10% of the units considered. The addition „d“ stands for „dangerous“. The value is for the creationa risk and hazard analysis relevant and thus also for the evaluation of the safety of a machine or plant. If there is no knowledge of the number of hazardous failures, EN ISO 13849-1 recommends the following calculation for the B10d value:  <math>B10d = B10 \times 2</math> This means that it is assumed that every second failure is a dangerous failure.</p>	x	
<b>Bistable relay, impulse relay, remanence relay</b>	<p>A relay is called bistable if its contacts can assume two different stable switching states when de-energised. This means that once the contact has changed its switching position due to the energising parameter (input voltage), it remains in its switching position after the energising parameter is switched off. A further energising process is required in order to change the switching position.</p> <p>Impulse relay:  A bistable relay that remains in an energised state due to mechanical interlock is called an impulse relay. Impulse relays switch over to the other switching state during an energising pulse and maintain this state until the next pulse.</p> <p>Remanence relay: A bistable relay that remains in an energised state due to remanence after the energising variable is switched off is called a remanence relay.</p> <p>To switch over to the other switching state:</p> <ul style="list-style-type: none"> <li>• Apply a voltage to a second coil</li> <li>• Apply a voltage with opposite polarity for relays with only one coil</li> </ul>	x	

EMR = Electromechanical relay  
SSR = Solid-state relay

		for EMR	for SSR
<b>Bounce (chatter)</b>	An unintended phenomenon that may occur in electromechanical relays, during the closing or opening of a contact circuit when the contact elements touch and separate again before they have reached their final positions. Solid-state relays do not exhibit this behaviour because they switch electronically, meaning that no mechanical bouncing can occur.	x	
<b>Bounce times</b>	The time (average value) between the first and last closing (or first and last opening) of a relay contact. These times are valid when the rated voltage is used for excitation without any other components connected in series or in parallel to the coil, and at the reference room temperature (approx. 23°C).	x	
<b>C</b>			
<b>CE</b>	Abbreviation for Communauté Européenne (the European Community). Manufacturers use the CE label to confirm that their products comply with the corresponding EC directives and the "essential requirements" therein.	x	x
<b>Clearance and creepage distances</b>	<p>Clearance and creepage distances are critical factors which influence the insulation capability of electrical components. The creepage distance denotes the minimum clearance that two live parts along a surface must have in order to prohibit a flow of current across the insulating material at the specified operating voltage.</p> <p>In addition to the operating voltage, the choice of insulating material (material group) and the protective measures to counteract pollution (pollution severity) affect the creepage distance. The clearance distance denotes the minimum direct clearance (through the air) that two live parts must have to one another in order to prohibit a charge passing through the air (an arc). The expected surge voltage (rated impulse voltage) forms the basis for calculating the distances. The surge protection category and pollution severity are further factors that influence dimensional design considerations.</p>	x	x

EMR = Electromechanical relay  
SSR = Solid-state relay

		for EMR	for SSR
<b>Coil resistance</b>	<p>Ohmic resistance (direct current resistance) of a relay coil measured at room temperature (approx. 23 °C) and coil temperature equal to room temperature. For AC coils, only the ohmic resistance is specified in the data sheet. The impedance, which can be calculated from the inductive resistance (reactance) and the ohmic resistance, only occurs during operation of AC coils and is considerably greater than the specified ohmic resistance. Therefore, the information in the data sheets for AC coils is not suitable for calculating the rated current of the coil.</p> <p>The coil resistance is heavily dependent on the coil temperature, which is influenced by parameters such as the ambient temperature, the rated control voltage and the duty cycle. Therefore, the values in the application may differ from the data sheet specifications.</p> <p>The coil resistance is only specified for relays and relay modules that have no other electronic components upstream from the coil. These types of inputs with upstream circuitry do not allow for reliable resistance data in the data sheet. For this reason, no resistance is specified in the data sheet for these inputs or for solid-state relays.</p>	x	
<b>Combination of relay and relay socket, insulation requirements and thermal characteristics</b>	<p>Even if the socket or relay itself already meets (or surpasses) the insulation requirements, there may still be reduced clearance and creepage distances (and thus reduced insulation rated voltage) for the combination of the relay and socket.</p> <p>Restrictions – such as a reduced voltage range or reduced pollution degree – should be expected for the relay/socket combination. This is especially important for miniature multi-pole relays in combination with sockets, which have minimal gaps between the contact circuits.</p> <p>In addition to the insulation properties, the thermal properties of the combination are highly significant (see item entitled "Derating curve"). The relay sockets from different manufacturers cannot be compared directly, which is why the technical specifications are only guaranteed for approved combinations. Possible risks of fire or reduced dielectric strength may result when non-approved combinations are in use.</p> <p><b>Note:</b> We only confirm the properties for the approved combinations of Weidmüller relays and Weidmüller sockets as specified in the catalogue and data sheets.</p>	x	x

EMR = Electromechanical relay  
SSR = Solid-state relay

		for EMR	for SSR
<p><b>Contact material, Contact materials</b></p>	<p>Relay modules are used in a wide variety of industrial areas and environments. The relays must therefore be adapted to the various tasks by selecting suitable contact materials. The following applies: the load capacity of the contacts for voltage, current, and power depends essentially on the material used. To make the selection easier for you, we have compared the most important characteristics of the contact materials.</p> <p>Criteria for the selection of the contact material:</p> <ul style="list-style-type: none"> <li>• Welding tendency</li> <li>• Burn-off resistance</li> <li>• Contact resistance</li> <li>• Material migration</li> <li>• Resistance to harmful gas atmospheres</li> </ul> <p><b>Material: Silver-nickel (AgNi)</b>                      Characteristics:</p> <ul style="list-style-type: none"> <li>• Higher welding tendency than AgSnO and AgCdO</li> <li>• High burn-off resistance</li> <li>• Lower contact resistance than AgSnO and AgCdO</li> <li>• Mean material migration</li> <li>• Low resistance to harmful gas atmospheres</li> </ul> <p>Recommended applications:</p> <ul style="list-style-type: none"> <li>• Suitable for low to high resistive and low inductive loads (solenoid valves, fans, heaters)</li> <li>• Standard contact material for a variety of relays</li> <li>• Limited suitable for high inrush currents</li> <li>• Suitable for loads &gt; 12 V/10 mA or 5 V/100 mA</li> </ul> <p><b>Material: Silver-nickel flash gold plated (AgNi + 0,15 Au)</b>                      Characteristics:</p> <ul style="list-style-type: none"> <li>• Higher welding tendency than AgSnO and AgCdO</li> <li>• High burn-off resistance (gold just storage protection)</li> <li>• Lower contact resistance than AgSnO and AgCdO</li> <li>• Mean material migration</li> <li>• Low resistance to harmful gas atmospheres</li> </ul> <p>Recommended applications:</p> <ul style="list-style-type: none"> <li>• Suitable for low to high resistive and low inductive loads (solenoid valves, fans, heaters)</li> <li>• The flash gold plating is a storage protection, but offers no functional improvement to AgNi</li> <li>• Limited suitable for high inrush currents</li> <li>• Suitable for loads &gt; 12 V/10 mA or 5 V/100 mA</li> </ul>	x	

EMR = Electromechanical relay  
 SSR = Solid-state relay



		for EMR	for SSR
<b>Contact material, Contact materials</b> (Continuation)	<p><b>Material: Silver-nickel hard gold plated (AgNi + Au)</b> Characteristics:</p> <ul style="list-style-type: none"> <li>• Very low resistance to burn-off</li> <li>• Lowest contact resistance</li> <li>• High resistance to harmful gas atmospheres</li> </ul> <p>Recommended applications:</p> <ul style="list-style-type: none"> <li>• Suitable for decoupling control inputs and other small resistive loads</li> <li>• Suitable for loads &gt; 1 V/1 mA and &lt; 30 V/10 mA</li> <li>• After switching loads &gt; 30 V/100 mA, small powers can no longer be switched reliably because the hard gold plating has been burned-off. Only the characteristics of the base contact material AgNi still apply.</li> </ul> <p><b>Material: Silver-Tin-Oxide (AgSnO)</b> Characteristics:</p> <ul style="list-style-type: none"> <li>• Lower welding tendency than AgNi</li> <li>• High resistance to burn-off</li> <li>• Average contact resistance</li> <li>• Lower material migration than AgNi</li> <li>• Very low resistance to harmful gas atmospheres</li> </ul> <p>Recommended applications:</p> <ul style="list-style-type: none"> <li>• Suitable for medium to high resistive DC-loads and low up to medium inductive DC loads due to low material migration. Thanks to the low tendency to weld, it is also well suited for loads with higher inrush currents such as lamp loads, light capacitive loads, fluorescent tubes, etc.</li> <li>• Suitable for loads &gt; 12 V/100 mA</li> </ul> <p><b>Material: Tungsten (W)</b> Characteristics:</p> <ul style="list-style-type: none"> <li>• Lowest welding tendency</li> <li>• Very high resistance to burn-off</li> <li>• Highest contact resistance</li> <li>• Low material migration</li> </ul> <p>Recommended applications:</p> <ul style="list-style-type: none"> <li>• Suitable for loads with very high inrush currents of up to 165 A/20 ms or 800 A/200 μs (e.g. lamp loads, capacitive loads, fluorescent tubes, switched-mode power supplies etc.)</li> <li>• Often used as a pre-making contact in parallel to AgSnO contacts</li> </ul>	x	
<b>Contact resistance</b>	<p>Electrical resistance between the closed relay contacts.</p> <p>In most applications, the contact resistance does not play a significant role in the reliability of a relay. However, a low contact resistance can only be reliably achieved above a certain load (see item entitled "Contact material" or "Minimum switching capacity").</p> <p>With very small loads, significantly higher contact resistances can occur, especially with switching voltages &lt; 30 V and switching currents &lt; 10 mA. In such cases, it is recommended to use hard gold-plated contacts.</p> <p>After the relay has been operated in a permanently off or on state for several days (e.g. due to adverse environmental conditions such as harmful gas atmospheres) or after it has been stored, it is recommended that a certain number of cycles be performed before measuring the contact resistance. This is achieved by means of electrical cleaning, which can be performed by switching a sufficient load and by self-cleaning caused by contact friction during the switching process.</p>	x	

EMR = Electromechanical relay  
SSR = Solid-state relay

		for EMR	for SSR
<b>Contact welding, Adhesive bonding (contacts) Capacitive loads</b>	Often occurs due to excessive inrush currents, e.g. when switching capacitive loads. See also the item entitled "Inrush currents". However, this can also occur when switching loads without high inrush currents, although this will often be at the end of the contact's service life. This happens due to material peaks on the contour surfaces which are caused by material migration and/or combustion. These material peaks then merge during the switch-on process, since the current of the load is conducted via this small contact point, which then leads to a brief but strong temperature increase that can weld the contacts.	x	
<b>Continuous current</b>	Current that can be carried continuously without exceeding the limit values for contact heating under certain conditions. Consider the derating curve. This current can also be switched on and off in the case of AC voltages. With DC voltages, this is only possible to a limited extent. See diagram: DC load limit curve.	x	x
<b>Continuous operation</b>	Operating mode in which a relay remains energised until it reaches thermal equilibrium. Unless otherwise specified, all Weidmüller relays are suitable for continuous operation.	x	x
<b>D</b>			
<b>DC load switching capacity, DC load limit curve, DC breaking capacity</b>	Values below the DC load switching capacity curve (for max. permitted switching voltage/current at resistive load) can be switched on and off reliably; e.g. an arc is extinguished (max. arc duration is 10 ms at resistive load). The position and shape of the load-limit curve is influenced by the contact material and relay construction (contact gap, opening speed of the contacts, etc.) The DC breaking capacity can be increased by connecting relay contacts in series. This is shown with dashed lines in the DC Load Limit Curves diagrams, if specified. For further information, please refer to the item entitled "Series connection of relay contacts". Information about the electrical lifespan should not be derived from these curves!	x	
<b>DC switching capacity (resistive), max.</b>	Calculated product for resistive loads from continuous current and switching voltage in W. When switching inductive loads, it is recommended to reduce the switching capacity in order to achieve the longest possible service life. The reduction results from the arc, which is significantly stronger when switching inductive loads than when switching resistive loads. The specified switching capacity refers to 24 V DC switching voltage. For other DC switching voltages, refer to the DC load limit curve provided in the data sheet.	x	

EMR = Electromechanical relay  
SSR = Solid-state relay

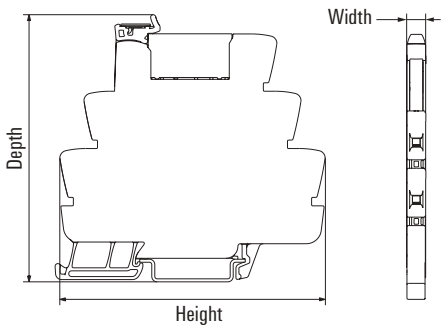
		for EMR	for SSR
<b>Derating / derating curve</b>	<p>Flowing current causes heat, which increases with increasing current intensity. Electric components have an upper limit temperature which limits their functionality. Because the temperature influence on the components is made up of the ambient temperature and the heat generated by the current, the current must be reduced as the ambient temperature increases so as not to exceed the upper limit temperature. The relationship between the prevailing ambient temperature and the resulting maximum current is shown in the derating curve. Unless otherwise specified, the derating curves are given for the following conditions:</p> <ul style="list-style-type: none"> <li>• Max. rated control voltage</li> <li>• 100% duty cycle</li> <li>• Resistive load</li> <li>• Closely packed with several identical products</li> <li>• Horizontally and vertically oriented terminal rail (in an upright cabinet)</li> <li>• No ventilation in the cabinet</li> <li>• No shading by cable conduits</li> </ul> <p>The heating of the product can be increased by the following parameters, which can lead to heating above the limit temperature and therefore to damage or even destruction of the product:</p> <ul style="list-style-type: none"> <li>• Shading, e.g. by cable conduits fitted too narrowly, which can lead to heat accumulation</li> <li>• High switching frequencies, especially when switching high currents or inductive loads (arcing)</li> <li>• Warmth from other devices mounted nearby</li> </ul> <p>The heating of the product can be reduced by the following parameters:</p> <ul style="list-style-type: none"> <li>• Reduction of shading by increasing the distances to cable conduits, for example</li> <li>• Increasing the ventilation in the control cabinet</li> <li>• Increasing the distance to adjacent products</li> <li>• Avoiding the effects of heat from other devices mounted nearby</li> </ul>	x	x
<b>Dielectric strength</b>	Voltage (RMS value for AC voltage, 50 Hz, 1 min) which can be applied between mutually insulated relay components during the voltage test.	x	x
<b>Dimensions</b>	<p>Dimensions in millimetres.</p>  <p>The drawing shows a top view of a relay module with dimensions labeled: Depth (vertical), Height (horizontal), and Width (horizontal, shown in a side view).</p>	x	x

EMR = Electromechanical relay  
SSR = Solid-state relay

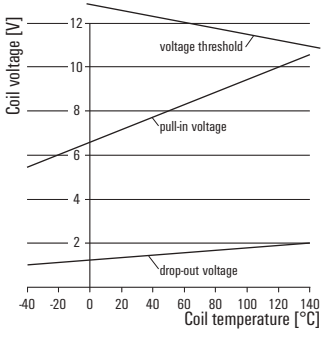

		for EMR	for SSR
<p><b>Drop-out current, typ</b></p>	<p>Typical current at which previously switched on monostable electromechanical relays and solid-state relays switch off.</p> <p>This means that this is the maximum input current value that must not be exceeded for switch-off in order to switch off the relays.</p> <p>They can also switch off at currents that are significantly higher than the specified value, since the specified value is a typical value at which they should be switched off.</p> <p>For AC, specifications are valid for 50 Hz unless otherwise indicated.</p> <p>Measured at room temperature (approx. 23 °C) and an only briefly energised input (coil temperature below thermal stability).</p> <p>The switching thresholds of electromechanical relays are strongly dependent on environmental parameters such as ambient temperature (see diagram below), mounting position, manufacturing tolerances (e.g. coil resistance) and the shape of the control signal. Therefore, the values in the application may differ from the data sheet specifications. The switching thresholds of solid-state relays fluctuate less, since the electronic components are less temperature-dependent than a relay coil.</p>  <p>The graph plots Coil voltage [V] on the y-axis (ranging from 0 to 12) against Coil temperature [°C] on the x-axis (ranging from -40 to 140). Three lines are shown: 'voltage threshold' starts at approximately 12V at -40°C and decreases to about 11V at 140°C; 'pull-in voltage' starts at approximately 6V at -40°C and increases to about 10V at 140°C; 'drop-out voltage' starts at approximately 1.5V at -40°C and increases slightly to about 2V at 140°C.</p>	x	x

EMR = Electromechanical relay  
 SSR = Solid-state relay

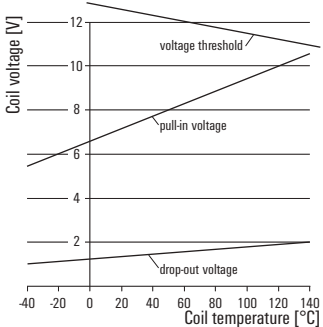

		for EMR	for SSR	
<b>Drop-out voltage, typ</b>	<p>Typical voltage at which previously switched on monostable electromechanical relays and solid-state relays switch off.</p> <p>This means that this is the maximum input voltage value that must not be exceeded for switch-off in order to switch off the relays.</p> <p>They can also switch off at voltages that are significantly higher than the specified value, since the specified value is a typical value at which they should be switched off.</p> <p>For AC, specifications are valid for 50 Hz unless otherwise indicated.</p> <p>Measured at room temperature (approx. 23 °C) and an only briefly energised input (coil temperature below thermal stability).</p> <p>The switching thresholds of electromechanical relays are strongly dependent on environmental parameters such as ambient temperature (see diagram below), mounting position, manufacturing tolerances (e.g. coil resistance) and the shape of the control signal. Therefore, the values in the application may differ from the data sheet specifications. The switching thresholds of solid-state relays fluctuate less, since the electronic components are less temperature-dependent than a relay coil.</p>	x	x	
 <p>The graph plots Coil voltage [V] on the y-axis (ranging from 0 to 12) against Coil temperature [°C] on the x-axis (ranging from -40 to 140). Three lines are shown: 'voltage threshold' starts at approximately 12V at -40°C and decreases to about 11V at 140°C; 'pull-in voltage' starts at approximately 6V at -40°C and increases to about 10V at 140°C; 'drop-out voltage' starts at approximately 1.5V at -40°C and increases slightly to about 2V at 140°C.</p>	<b>Duty cycle, relative duty cycle</b>	<p>Describes the ratio of the switched-on state of a relay or solid-state relay to the total duration in intermittent, continuous or short-time operation. The duty cycle is expressed as a percentage of the total cycle duration.</p> <p>The heating of the relay can be influenced positively or negatively by the duty cycle.</p> <p>A high duty cycle leads to increased heating of the relay due to the power loss of the coil and the switching contacts.</p> <p>Unless otherwise specified, Weidmüller relay modules and solid-state relays are suitable for 100% duty cycle (continuous operation).</p> <p>With very fast switching solid-state relays, the duty cycle also affects the maximum switching frequency. This is then indicated in the corresponding diagrams in the data sheet.</p>	x	x

EMR = Electromechanical relay  
SSR = Solid-state relay



		for EMR	for SSR
<b>E</b>			
<b>Electrical endurance, Electrical endurance curve, contact endurance</b>	<p>Number of switching cycles of a relay with electrical contact load under full operational capability. Unless otherwise stated, the contact data and electrical lifespan curves are valid under the following conditions:</p> <ul style="list-style-type: none"> <li>• Measured at the NO contact</li> <li>• Resistive AC load</li> <li>• AC mains frequency 50 Hz</li> <li>• Duty cycle 50%</li> <li>• Switching frequency 0.1 Hz</li> <li>• Rated control voltage (coil)</li> <li>• Ambient temperature 23°C</li> <li>• Individual assembly</li> </ul> <p>The electrical lifespan is specified according to the criteria for 'useful life', severity level B according to IEC 61810-2. The data does not cover any use beyond the specified electrical lifespan; it is the responsibility of the user to avoid such situations. Experience has shown that the electrical lifespan remains relatively constant with an AC load up to a power factor (<math>\cos \phi</math>) of 0.8.</p> <p>However, each load places different demands on the switching contact and other environmental factors also influence the service life of the switching contact, e.g. the type of load, the switching voltage at the contact, the switching current of the load, any inrush currents, the ambient temperature, the mounting position, the switching frequency and many more.</p> <p>Therefore, the real service life could be either above or below the specified value. For loads other than those specified in the service life data, it is recommended that user advice be followed; alternatively, recommendations can be found in the selection table in Chapter A.</p> <p>For critical applications it is recommended that the service life values be determined independently by the user.</p> <p><b>Please note:</b> The curve for the electrical lifespan specifies the typical service life as the "Mean Cycles to Failure" (MCTF) and is based on the Weibull distribution. No guaranteed minimum values can be interpreted from this statistical data. The electrical lifespan must not be compared with the mechanical lifespan when switching larger or inductive loads, as the mechanical lifespan is measured without contact load and the failure criteria are different. The difference between the mechanical and electrical lifespans becomes greater as the switching current increases. For more information on the mechanical lifespan, see item entitled "Mechanical lifespan".</p>	x	

EMR = Electromechanical relay  
SSR = Solid-state relay

		for EMR	for SSR
<b>Error, relay failure</b>	<p>According to IEC 61810, a relay failure is defined as the occurrence of malfunctions that exceed a certain number:</p> <ul style="list-style-type: none"> <li>• Malfunction when closing contacts</li> <li>• Malfunction when opening contacts (contact bridging in CO contact as a special form of malfunction when opening contacts)</li> <li>• Insufficient dielectric strength.</li> </ul> <p>Such malfunctions must be considered in the scope of the application – they should not create any risks. Depending on the specific load and the power in the contact set, malfunctions can result in various risks such as malfunctioning of the device and its controls, electric shock and excessive heating or even fire. The user is responsible for taking the necessary precautions in accordance with the relevant regulations.</p>	x	
<b>F</b>			
<b>Flammability according to UL</b>	Indicates the flammability class according to the specification from UL 94 (Underwriters Laboratories, Inc., USA). Flammability tests according to UL 94: for testing plastic materials and classifying the propagation/extinction characteristics when the material burns. The UL 94 flammability classes which are relevant to relays are V-0, V-1, V-2 and HB.	x	x
<b>G</b>			
<b>Galvanic isolation</b>	Potential-free isolation between electrical components. Electrical (or galvanic) isolation means that no charge can flow from one circuit to another. There is no conductive electrical connection between the circuits. The circuits can nevertheless exchange electrical power or signals via magnetic fields, infrared radiation or by charge displacements.	x	x
<b>H</b>			
<b>Humidity, relative humidity, condensation</b>	Ratio between the actual and the maximum possible mass (quantity) of water vapour in the air - Unit: % When storing or operating under other conditions, steps must be taken to avoid temperature changes/shocks which could cause icing or condensation. The plastic used in the products can expand due to high humidity and contract due to low humidity, which can lead to increased insertion and pulling forces of cross-connections and other accessories.	x	x
<b>I</b>			
<b>Impulse withstand voltage</b>	Amplitude of a voltage pulse of short duration with a specific pulse shape (e.g. 1.2/50 µs) and polarity, which is used to test insulation paths in a product.	x	x

EMR = Electromechanical relay  
SSR = Solid-state relay

		for EMR	for SSR
<b>Inrush current (output)</b>	<p>The highest value of current that can be switched on by an output of a relay module or solid-state relay.</p> <p>This current is specified along with a time for which it can be carried.</p> <p>The inrush current for some loads can be considerably higher than the specified rated current. Loads with a capacitive load component, especially LED lamps, place extreme demands on the switching contacts regardless of the type of voltage. They have extremely high-energy current peaks at the moment of switch-on. These can reach over 100 A and can weld the contact right from the first switch-on.</p> <p>Therefore, when selecting the relay, consideration must be given as to whether high inrush currents will be generated by the load being switched.</p> <p>Potential loads with high inrush currents are:</p> <ul style="list-style-type: none"> <li>• Lamp loads, especially LED lamps</li> <li>• Power supplies</li> <li>• Loads with wide-range inputs (e.g. with control voltages of 110-230 V AC/DC) such as solenoid valves and contactors</li> <li>• Loads with other special input circuits such as energy-saving circuits</li> <li>• Motor loads with high starting torques, e.g. gears</li> <li>• Servomotors</li> </ul> <p>For these types of loads, it is recommended that special relay couplers (e.g. relay modules with tungsten pre-run contact) be avoided.</p> <p>Furthermore, solid-state relays are also very well-suited to high but short inrush current peaks, as they do not contain any mechanical components and therefore cannot fail.</p>	x	x
<b>Instantaneous switching</b>	<p>Solid-state relays with AC outputs such as triacs or thyristors which switch on immediately on switch-on and switch off at the zero crossing of the switching current. For this reason, switching off may be delayed depending on the phase position at the time of switching and on the mains frequency of the switching current.</p> <p><b>Signal characteristics of instantaneous switching PSSR</b> shown at an example with resistive load</p> <p><math>t_{on\ max} \leq 0.1\ ms</math>      <math>t_{off\ max} \leq 10\ ms</math></p>		x

EMR = Electromechanical relay  
SSR = Solid-state relay

		for EMR	for SSR
<b>Insulating material group</b>	<p>According to their CTI (comparative tracking index) values, the insulating materials are categorised in one of the following four groups:</p> <p>Group I 600 CTI Group II 400 CTI &lt; 600 Group IIIa 175 CTI &lt; 400 Group IIIb 100 CTI &lt; 175</p> <p>The figures for the comparative tracking index, according to IEC 60112 (DIN IEC 60112 / DIN VDE 0303-1) are determined using special samples prepared for this purpose with test solution A.</p>	x	x
<b>L</b>			
<b>Leakage current</b>	The current on the load side of a solid-state relay that flows when the output stage is in the locked state. It flows because a solid-state relay does not provide galvanic isolation of the output, as is the case when there is an air gap when the contact of an electromechanical relay is open. The output of a solid-state relay only becomes high-impedance when it is locked, meaning that only a very small amount of current is flowing. Solid-state relays with AC output often have an RC protective suppressor circuit in parallel to the output, which is why leakage currents of up to 2 mA can flow in the locked state.		x
<b>Load limit integral (I<sup>2</sup>t)</b>	The load limit integral (I <sup>2</sup> t), specified in A <sup>2</sup> s, is the pulse-shaped (< 10ms) short-term overload capacity of the semiconductor switch in solid-state relays or semiconductor contactors. It is used to select a fuse as device protection for the output of a semiconductor switch. If this value is exceeded, the semiconductor switch may be destroyed; when selecting the fuse size, it is therefore recommended that the I <sup>2</sup> t of the fuse is half the size of the semiconductor switch.		x
<b>M</b>			
<b>Max. reset time in the case of a voltage interruption, recovery time</b>	Time that needs to elapse after the excitation variable has been switched off in order for the timing relay to fulfil a function again as specified.	x	x
<b>Max. switching frequency (DC and AC control voltage)</b>	<p>Number of switching cycles per time unit of a solid-state relay with continuous current and resistive load.</p> <p>When switching inductive loads with switching frequencies faster than 0.5 Hz, an external protective suppressor circuit must be connected in parallel with the load.</p> <p>If this is not possible, solid-state relays specially designed for switching inductive loads must be selected.</p> <p>Due to the input wiring of the solid-state relay (e.g. bridge rectifier and smoothing capacitor), different switching frequencies can often be implemented for solid-state relays with AC/DC (UC) input. These specifications are therefore listed separately in the data sheet.</p>		x
<b>Max. switching frequency at rated load</b>	<p>Number of switching cycles per time unit of an electromechanical relay at max. switching capacity and resistive load.</p> <p>The switching frequency for small and medium loads can be higher than the value specified in the data sheet if the switching characteristics of the load (such as arcing) do not overload the contact to an impermissible extent.</p>	x	

EMR = Electromechanical relay  
SSR = Solid-state relay

		for EMR	for SSR
<b>Mechanical service life</b>	<p>The number of switching cycles for current-free relay contacts for which the relay must remain functional under specific conditions.</p> <p>Although the mechanical lifespan is determined without a contact load, it can give an indication of the electrical lifespan with contact loads &lt; 100 mA (resistive load).</p> <p>The mechanical lifespan must not be compared with the electrical lifespan when switching larger or inductive loads, as the mechanical lifespan is measured without contact load and the failure criteria are different. The difference between the mechanical and electrical lifespans becomes greater as the switching current increases. For more information on the electrical lifespan, see item entitled "Electrical lifespan".</p>	x	
<b>Mechanical switch position indicator</b>	Plastic lever inside some electromechanical relays, which is mechanically connected to the armature. The switching position of the relay armature can therefore be seen through an inspection window in the relay cover.	x	
<b>Min. pulse duration</b>	Shortest required period for the start impulse to start the time function of a timing relay.	x	x
<b>Min. switching current</b>	Specifies the minimum switching current of the output of a semiconductor switch. A semiconductor output, in particular triacs and thyristors, requires a minimum load current to open and close reliably.		x
<b>Minimum switching capacity</b>	<p>The calculated product of the switching current and switching voltage – a measure of reliable switching.</p> <p>Low contact resistance values are only achieved above a certain power, because when switching loads above this power, a sufficient arc is generated that burns away or breaks through oxidation layers and dirt (electrical cleaning). Greatly increased resistances may occur at lower switching loads, which can prevent the load circuit from being reliably switched.</p> <p>The switching voltage has a greater effect than the switched current when switching small powers, because the formation of an arc is more dependent on the switched voltage than on the switched current.</p> <p>The minimum contact loads for different contact materials should also be taken into account. (see item entitled "Contact materials")</p> <p>By switching regularly (at least several times a day), it is also possible to switch powers below the minimum contact loads of the various contact materials (except for hard gold-plated contacts). This is achieved by the self-cleaning effect caused by contact friction during the switching process.</p> <p>The minimum switching capacity can be negatively affected by harmful gas atmospheres in the ambient air.</p>	x	
<b>Mono-stable relay</b>	A relay is referred to as mono-stable when its contacts return to the state of rest automatically after the energising parameter (the input voltage) is switched off.	x	x

EMR = Electromechanical relay  
SSR = Solid-state relay

		for EMR	for SSR
<b>Mounting distance</b>	<p>Distance between two adjacent components when using parallel, same orientated positioning; or the distance to other electrical components, e.g. on a terminal rail. Because of the insulation requirements or the self-heating (derating) it may be necessary to increase the minimum gap between the components or select a different positioning. Self-heating can be improved by increasing the mounting distance. This can help to reduce the derating of the switching current. In addition to this definition, the following applies:</p> <ul style="list-style-type: none"> <li>• Densely packed installation: Designed with minimum mounting distance to products from the same Weidmüller product series. Unless otherwise stated, from the point of view of self-heating, Weidmüller relay modules and solid-state relays are suitable for densely packed installation with other products from the same Weidmüller product series. It is recommended that there should be a mounting distance between these and other components from other Weidmüller product series or components from other manufacturers, as this can lead to a reduction in the insulation properties or to an unacceptable increase in self-heating.</li> <li>• Individual installation: components are mounted with gaps so that there are no thermal influences from adjacent components.</li> </ul>	x	x
<b>Mounting position</b>	<p>Electromechanical relay modules and solid-state relays (SSR) from Weidmüller can be installed in almost any position unless otherwise specified in the data sheet. The mounting positions used in the industrial environment are: mounted on a terminal rail in a horizontal or vertical installation position in an upright control cabinet. These positions are also checked when determining the derating curves. However, the most common method of installation is on a horizontally aligned terminal rail. It is not recommended to install the relays upside down (relay pointing downwards) as this is not taken into account when determining the derating curves. This would also lead to heat accumulation and the risk of a pluggable relay slipping out of the socket due to vibrations. To ensure the proper current flow and heat dissipation, the connections must have adequate cross-sections. Several factors must be taken into consideration when positioning: including the insulation requirements, heat dissipation and the possible mutual magnetic and thermal influence.</p>	x	x
<b>MTTF</b>	<p>MTTF is the abbreviation for Mean Time To Failure and is also designated as the mean operating service life. For relay modules and solid-state relays, the MTTF value is equal to the MTBF because no repair is performed on the products. They are replaced after a defect, which means that there is no repair time.</p> <p>The MTTF value of relay modules is calculated on the basis of the B10 value (see item entitled "B10 value") and the switching cycles occurring in the application. It can be calculated using the following formula for electromechanical relays:</p> $MTTF = B10 \div (0.1 \times n)$ <p>The value "n" is the number of annual switching cycles in the application. The user must enter this value together with the appropriate B10 value in the formula in order to calculate the possibility of failure of the relays used in the application. The MTTF value of solid-state relays is calculated using the parts counting method, based on the basic failure rates from SN29500. This is possible because a solid-state relay is not subject to mechanical wear, meaning that the statistical failure values of the individual components within the solid-state relay can be added together. Electrical connections and plug-in connections were not taken into account when calculating the values specified in the data sheet.</p> <p>The failure rates of electronic components increase considerably after approx. 8 to 12 years, causing the MTTF values to decrease (see EN 61508-2: 2011-02, 7.4.9.5, Note 3).</p>	x	x

EMR = Electromechanical relay  
SSR = Solid-state relay

		for EMR	for SSR
<b>N</b>			
<b>Nominal torque</b>	The specified value for the torque of the screws (screw connection) must not be exceeded.	x	x
<b>O</b>			
<b>Operating temperature</b>	Permissible ambient temperature – relative to a specific relative humidity – at which a product should be operated at nominal load.	x	x
<b>Operational voltage range</b>	<p>Permissible range of the input voltage depending on the ambient temperature. Operating voltage range curve in the data sheet:</p> <p>The top part of the range is specified by the maximum voltage;                      the lower part of the range is specified by the response/minimum voltage</p> <p>Curve 1: Response/minimum voltage <math>U_0</math> (without pre-excitation)                      Curve 2: Response/minimum voltage <math>U_1</math> (after pre-excitation)                      Curve 3: Maximum voltage <math>U_2</math>, contact current = 0 A                      Curve 4: Maximum voltage with contact current <math>I_{nenn}</math></p> <div data-bbox="502 1019 837 1332" data-label="Figure"> <p>The graph shows the relationship between coil voltage and ambient temperature. The y-axis is 'Coil voltage [U/U<sub>rated</sub>]' ranging from 0.6 to 2.2. The x-axis is 'Ambient temperature [°C]' ranging from 0 to +100. Curve 1 (bottom) is the response/minimum voltage without pre-excitation. Curve 2 (middle) is the response/minimum voltage after pre-excitation. Curve 3 (top) is the maximum voltage at 0 A contact current. Curve 4 (top) is the maximum voltage with contact current. A horizontal line at U<sub>rated</sub> is labeled 'Rated voltage'. The graph is divided into two regions: '0 A' (top) and '&gt; 0 A' (bottom).</p> </div> <p>The diagrams are valid for the single mounting of relays without thermal interference and connection wiring according to IEC 61810-1; unless otherwise indicated, the data is displayed without contact load and without taking into account the temperature rise due to the contact current.</p> <p>If no operating voltage range curve is specified in the data sheet, the tolerances in per cent (%) can be found in the rated control voltage characteristic.</p> <p>The use of a relay with an excitation voltage other than the rated coil voltage can lead to a reduced electrical lifespan (mechanical and dynamic effects).</p>	x	x
<b>P</b>			
<b>Packing unit</b>	Indicates the smallest amount (a pack, for example) or the quantity per carton.	x	x
<b>Plug-in cycles</b>	Sockets and accessories are designed for 10 insertion cycles without electrical load – unless otherwise specified.	x	x

EMR = Electromechanical relay  
 SSR = Solid-state relay

		for EMR	for SSR
<b>Pollution severity level</b>	<p>Pollution (contamination) includes any foreign material – whether it is solid, liquid or gaseous (ionised gas) – which is capable of influencing the surface resistance of the insulating material. The standard defines four degrees of pollution. Their numbering and classification is based on the quantity of the contaminant or the frequency with which the contaminant reduces the dielectric strength and/or surface resistance.</p> <p>Pollution degree 1:</p> <ul style="list-style-type: none"> <li>• there is no contamination or only dry occurrences of non-conductive pollution. The pollution has no influence.</li> </ul> <p>Pollution degree 2:</p> <ul style="list-style-type: none"> <li>• there is only non-conductive pollution. Temporary occurrences of conductivity caused by condensation may also occur.</li> </ul> <p>Pollution degree 3:</p> <ul style="list-style-type: none"> <li>• conductive pollution or dry, non-conductive pollution that can become conductive due to condensation is likely to occur.</li> </ul> <p>Pollution degree 4:</p> <ul style="list-style-type: none"> <li>• the contamination leads to continual conductivity which can be caused by contaminants such as conductive dust, rain or snow.</li> </ul>	x	x

EMR = Electromechanical relay  
 SSR = Solid-state relay



		for EMR	for SSR
<b>Positively driven contacts</b>	<p>Relays with positively driven contacts according to EN 61810-3 are characterised by the fact that, due to a mechanical guide, the NO and NC contacts of a relay cannot be closed at the same time.</p> <p>Design differences compared to relays with standard contacts: In relays with positively driven contacts, some components within the relay have a more heavy-duty design. This is the case for components such as the contact springs and the armature.</p> <p>This is in order to reduce the possibility of a dangerous failure. However, it also means that the coils in these relays need to be stronger in order to move the larger or heavier parts. As a result, these types of relays have up to twice the power consumption compared to standard relays.</p> <p>In addition, there is more insulation between the input and output and between the output channels in relays with positively driven contacts compared to standard relays of the same size.</p> <p>To use relays with positively driven contacts for safety applications, at least one of the relay's NO contacts and one of its NC contacts must be integrated into the circuit design. The NO contact of the first channel then switches the function in the safety application and the NC contact of a second channel gives a feedback signal to the control unit. This means that if one of the NO contacts welds, for example, the following function step of the application cannot be initiated and the circuit is stopped because the NC contact cannot give a feedback signal due to the fact that the NO is welded.</p> <p>The standard EN 61810-3 describes the requirements for relays with positively driven contacts.</p> <ul style="list-style-type: none"> <li>• Type A: Type A relays only have NO and NC contacts</li> <li>• Type B: Type B relays have CO contacts; in applications where the positively driven contact function is to be used, only the NO or NC contacts of a CO contact may be used.</li> </ul>	x	
<b>Power rating (input)</b>	<p>The nominal value of the power that is converted when the rated control voltage is applied in individual installation.</p> <p>For AC, specifications are valid for 50 Hz unless otherwise indicated.</p> <p>Measured at room temperature (approx. 23 °C) and an only briefly energised coil (coil temperature below thermal stability).</p> <p>The power rating depends on environmental parameters such as the ambient temperature, the mounting position and the manufacturing tolerances (coil resistance). Therefore, the values in the application may differ from the data sheet specifications.</p>	x	x

EMR = Electromechanical relay  
SSR = Solid-state relay

		for EMR	for SSR
<p><b>Protection degree – (IEC 60529), IP</b></p>	<p>The degree of protection afforded by an enclosure is shown using the IP Code (IP = International Protection). This information is equally relevant for industrial relays and accessories.</p> <p>Protection levels for touch contact and foreign bodies (the first digit): the first digit indicates the degree of protection inside the housing against ingress of solid foreign objects and against any human access to hazardous parts.</p> <p>0: no protection                      1: protection for large body parts with a diameter &gt; 50 mm                      2: finger protection (diameter 12 mm)                      3: tools and wires (diameter &gt; 2.5 mm)                      4: tools and wires (diameter &gt; 1 mm)                      5: full protection against touch contact                      6: full protection against touch contact</p> <p>Degree of water protection (the second digit)</p> <p>Degrees of protection: water protection (2nd digit)                      The second digit indicates the degree of protection provided against the ingress of water into the housing:</p> <p>0: no protection                      1: protection against vertically falling drops of water                      2: protection against water droplets falling diagonally (up to 15°)                      3: protection against water spray that falls at an angle up to 60° from vertical                      4: protection against splashed water from all sides                      5: protection against water jets                      6: protection against powerful jets of water (flooding)                      7: protection against sporadic submersion                      8: protection against constant submersion</p>	x	x

EMR = Electromechanical relay  
 SSR = Solid-state relay



		for EMR	for SSR
<p><b>Protective circuit on the control side (solid-state relay) or protective circuit (electromechanical relay) at the input</b></p>	<p>The protective suppressor circuit at the input can either be plugged into the socket by a plug-in module or it can be integrated into the electromechanical relay or the solid-state relay. The various protective suppressor circuits and their function are explained below:                      Free-wheeling diode:                      Protects only the control electronics from the inductive cut-off voltages of the relay coil of an electromechanical relay with DC coil.                      Attention: If no additional reverse polarity protection has been previously installed, a short circuit can be caused by reverse polarity.                      Varistor:                      Protects the input of an electromechanical relay or solid-state relay from surge voltages.                      In electromechanical relays, it also protects the control electronics from the inductive cut-off voltages of the relay coil.                      Rectifier:                      Enables AC and DC voltages to be connected as a protective suppressor circuit in the input without prescribing a polarity direction.                      In electromechanical relays, it also protects the control electronics from the inductive cut-off voltages of the coil.                      RC element:                      Protects the control electronics from the inductive cut-off voltages of the relay coil of an electromechanical relay with AC coil.                      Coupled voltages in long control lines at the input may mean that an electromechanical relay or solid-state relay no longer switches off reliably.                      An RC element allows for the reduction of the coupled voltages, which can cause the electromechanical relay or solid-state relay to drop out.</p>	x	x
<p><b>Protective circuit, load side (solid-state relay)</b></p>	<p>Protective suppressor circuit integrated in the output of the solid-state relay.                      The protective suppressor circuit at the output of a solid-state relay protects the output against surge voltages such as those that occur when switching off inductive loads.                      Due to the very compact design of pluggable solid-state relays such as those used in the TERMSERIES as well as the limited heat dissipation, the protective suppressor circuit of these solid-state relays often only offers protection against small surge voltages, e.g. from very light inductive loads.                      It is therefore highly recommended to have an additional external protective suppressor circuit parallel to the load when switching inductive loads with these pluggable solid-state relays. Otherwise, the semiconductor output may be destroyed.                      When switching inductive loads with switching frequencies faster than 0.5 Hz, an external protective suppressor circuit must be connected in parallel with the load.                      If this is not possible, solid-state relays specially designed for switching inductive loads must be selected.</p>		x

EMR = Electromechanical relay  
 SSR = Solid-state relay



		for EMR	for SSR
<b>Pull-in current, typ (input)</b>	<p>Typical current at which monostable electromechanical relays and solid-state relays reliably switch on.</p> <p>This means that this is the minimum input current value that must not be fallen below for switch-on in order to switch on the relays.</p> <p>They can also switch on at currents that are lower than the specified value, since the specified value is a typical value at which they should be switched on.</p> <p>For AC, specifications are valid for 50 Hz unless otherwise indicated.</p> <p>Measured at room temperature (approx. 23 °C), coil temperature equal to room temperature and cold coil (without pre-excitation).</p> <p>The switching thresholds of electromechanical relays are strongly dependent on environmental parameters such as ambient temperature (see diagram below), mounting position, manufacturing tolerances (e.g. coil resistance) and the shape of the control signal. Therefore, the values in the application may differ from the data sheet specifications.</p> <p>The switching thresholds of solid-state relays fluctuate less, since the electronic components are less temperature-dependent than a relay coil.</p>	x	x

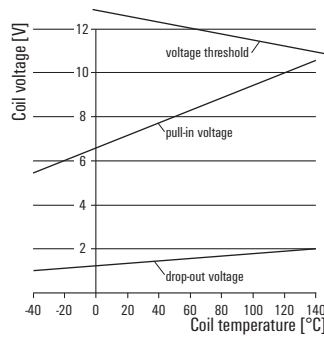

EMR = Electromechanical relay  
 SSR = Solid-state relay

		for EMR	for SSR
<b>Pull-in voltage, typ (input)</b>	<p>Typical voltage at which monostable electromechanical relays and solid-state relays switch on. This means that this is the minimum input voltage value that must not be fallen below for switch-on in order to switch on the relays. They can also switch on at voltages that are lower than the specified value, since the specified value is a typical value at which they should be switched on. For AC, specifications are valid for 50 Hz unless otherwise indicated. Measured at room temperature (approx. 23 °C), coil temperature equal to room temperature and cold coil (without pre-excitation). The switching thresholds of electromechanical relays are strongly dependent on environmental parameters such as ambient temperature (see diagram below), mounting position, manufacturing tolerances (e.g. coil resistance) and the shape of the control signal. Therefore, the values in the application may differ from the data sheet specifications. The switching thresholds of solid-state relays fluctuate less, since the electronic components are less temperature-dependent than a relay coil.</p> <p>The graph plots Coil voltage [V] on the y-axis (ranging from 0 to 12) against Coil temperature [°C] on the x-axis (ranging from -40 to 140). Three lines are shown: 'voltage threshold' starts at approximately 12V at -40°C and decreases to about 10.5V at 140°C; 'pull-in voltage' starts at approximately 6V at -40°C and decreases to about 4.5V at 140°C; 'drop-out voltage' starts at approximately 1.5V at -40°C and increases slightly to about 2V at 140°C.</p>	x	x
<b>R</b>			
<b>Rated control voltage</b>	<p>Rated voltage at which the relay is to be operated and at which other input and output characteristics are measured. For AC, specifications are valid for 50 Hz unless otherwise indicated. Control with other operating modes, such as pulse width modulation (PWM) or half-wave rectification, can lead to changes in the input and output characteristics, which are measured with the rated control voltage.</p>	x	x
<b>Rated current DC or AC (input)</b>	<p>Rated current that the relay draws when controlled with rated control voltage. For AC, specifications are valid for 50 Hz unless otherwise indicated. Measured at room temperature (approx. 23 °C) and an only briefly energised input (coil temperature below thermal stability). Control with other operating modes, such as pulse width modulation (PWM) or half-wave rectification, can lead to changes in the input and output characteristics, which are measured with the rated control voltage.</p>	x	x
<b>Rated switching voltage</b>	<p>The value of the nominal mains voltage with the standard tolerances found in the mains, which the contact can switch on the basis of the insulation data.</p>	x	x
<b>Rated voltage (Isolation)</b>	<p>Voltage level at which the insulation specifications are measured – this is the basis for sizing the clearance and creepage distance.</p>	x	x

EMR = Electromechanical relay  
SSR = Solid-state relay

		for EMR	for SSR
<b>Relay times (time response) electromechanical relays</b>	<p>Because of the self-inductance of the coil and the inertia of the moving parts, the steps involved in operating a relay do not occur instantaneously. The following chart illustrates several time-function terms for the main contact variants of non-delayed switching relays.</p> <p>The diagram illustrates the timing of a relay's operation. It shows the state of the coil voltage, the position of the moving parts, and the voltage across the normally open (NO) and normally closed (NC) contacts over time. The sequence starts at a 'Rest position' where the coil is de-energized. When the coil is energized, there is a 'Switch-on delay' before the moving parts reach the 'Working position'. While in the working position, the NO contact is closed and the NC contact is open. When the coil is de-energized, there is a 'Switch-off delay' before the moving parts return to the 'Rest position'. The diagram also shows 'Bounce time' for the contacts during both the switch-on and switch-off transitions.</p>	x	
<b>Repeat accuracy</b>	Difference between the highest and lowest time range values for several measurements of a timing relay's time response under identical conditions. The value is given as a percentage of the mean value of all measured values.	x	x
<b>Rest position</b>	The switched position of a mono-stable relay in its de-energized state.	x	
<b>RoHS Directive</b>	RoHS stands for "Restriction of (the use of certain) Hazardous Substances". According to the EU Directive 2011/65/EU from 01.07.2011, all EU member nations must forbid the use of hazardous substances which damage human health and the environment (including mercury (Hg), cadmium (Cd), lead (Pb), hexavalent chrome (Cr6), polybrominated biphenyls (PBB) and polybrominated diphenyl ethers (PBDE)) in new electrical and electronic devices. The term "compliant" means that the entire product group meets the requirements of the RoHS Directive.	x	x

EMR = Electromechanical relay  
SSR = Solid-state relay



		for EMR	for SSR
<b>S</b>			
<b>Schmitt trigger</b>	Strictly speaking, switching voltages for digital control follow an analogue pattern (no changeover from 0 to 1 between maximum and minimum voltages). This can lead to inaccuracies in switching results, above all when signals are being transmitted rapidly. In this case, the Schmitt trigger functions as a threshold switch. If the threshold voltage set in the Schmitt Trigger is exceeded, the output assumes the maximum possible output voltage (logic 1). Otherwise it is the minimum possible output voltage (logic 0). The Schmitt trigger is normally designed with a hysteresis. The threshold voltage set for activating is higher than that for deactivating. That prevents small irregularities from triggering a switching operation.		x
<b>Self-heating</b>	The heating up of an operational component based on the power loss from the relay coil and the switching contacts.	x	
<b>Self-heating, power loss</b>	The heating up of a relay module or solid-state relay during operation due to the power consumption of the input and the power loss from the switching contacts. The standard DIN EN 6 1439 "Low-voltage switchgear and controlgear assemblies - Part 1: General rules" requires that the heating up of a switching combination be determined for planners, panel builders and installers. The power loss of all installed equipment must be taken into account. However, this presupposes that the respective manufacturers of the equipment make the corresponding values available. In practice, determining the actual power loss for certain equipment is difficult and only possible with a lot of effort. This also includes electromechanical relays and relay modules. We would like to provide you with a simple recommendation to help calculate these power loss values for Weidmüller relay modules and solid-state relays.	x	x
<b>Self-heating, power loss</b>	Power loss in electromechanical relays: The power loss of a relay module can be calculated by adding the input power specified in the data sheet to the output power loss. If you want to determine the real power loss for the output, this depends on a number of parameters such as switching current, switching frequency, ambient temperature, arcing time, etc. Performing the calculation using all these values would be almost impossible, because many of these parameters are not known. Therefore, we recommend calculating the power loss at the output using a highly simplified formula of contact resistance and switching current: $P = I^2 \times R$ The contact resistance is dynamic during the service life, and increases due to wear, e.g. contact erosion towards the end of the service life. Weidmüller recommends using 10 mOhm (0.01 Ohm) as the contact resistance for calculating the output power loss of a relay module. It is not recommended to measure the contact resistance with a multimeter, because this can give completely incorrect values. For the maximum power loss, simply insert the continuous current from the data sheet into the formula. To calculate a value that is closer to the real power loss, it is recommended to insert the actual current switched in the application into the formula. These formulas calculate the power loss for 100% duty cycle. If you now want to determine the value more accurately, the power loss should be multiplied by the duty cycle (in per cent). With a duty cycle of 50%, the power loss would be halved.	x	

EMR = Electromechanical relay  
SSR = Solid-state relay

		for EMR	for SSR
<b>Self-heating, power loss</b>	<p>Power dissipation in solid-state relays:</p> <p>The power loss calculation in solid-state relays behaves in almost the same way as that of electromechanical relays. Here, however, the maximum voltage drop specified in the data sheet is used instead of the contact resistance. This voltage drop is essentially dependent on the switched current. At low switching currents, the voltage drop is low, but it is recommended to use the maximum voltage drop from the data sheet. The highly simplified formula is then as follows:</p> $P = U_{\text{voltage drop}} \times I$ <p>For the maximum power loss, simply enter the continuous current from the data sheet into the formula. In order to calculate a value that is closer to the real power loss, it is recommended to insert the actual current switched in the application into the formula</p> <p>These formulas calculate the power loss for 100% duty cycle. If you now want to determine the value more accurately, the power loss should be multiplied by the duty cycle (in per cent). With a duty cycle of 50%, the power loss would be halved.</p>		x
<b>Series-circuit connection of relay contacts</b>	<p>The serial connection of 2 or more NO contacts of a relay causes the contact opening to increase on switch-off. Arcs which occur from DC loads are cleared more quickly which results in reduced burn-off on the contact. This increases the electrical endurance or the possible switching current or switching voltage. The possible switching current or the possible switching voltage is shown with dashed lines in the DC load limit curves diagrams, if specified. Information about the electrical endurance should not be derived from these curves!</p>	x	
<b>Setting tolerance</b>	<p>Difference between the measured value of the delay period and the set value on the time relay.</p> <p>The specification refers to the full scale value.</p> <p>The setting tolerance is measured directly at the relay contacts, i.e. a time is set using the scale on the device and then measured.</p> <p>The input signal (start of time measurement) is either the power supply or the control contact, depending on the definition of the function.</p> <p>The time measurement is ended by switching the output contact.</p>	x	x
<b>Short-circuit-proof</b>	<p>Switching off the output stage of some solid-state relays whose output was developed to be short-circuit proof in order to protect the output circuit from damage in the event of a short circuit.</p> <p>Solid-state relays without a special design in the output are not short-circuit proof and must be protected with a special fuse for device protection. A short-circuit-proof output does not release the user from the obligation to install line protection to protect the installation.</p>		x
<b>SIL</b>	<p>Safety Integrity Level. To reduce risk, the components must comply with the requirements of IEC 61508. This standard provides general requirements for avoiding and minimising device and equipment outages. It stipulates organisation and technical requirements concerning device design and operation. Four safety levels are distinguished for systems and risk-reducing measures, ranging from SIL1 for low risk to SIL4 for very high risk. Measures taken to reduce risk must be more reliable when the classified risk level is higher.</p>	x	x
<b>Solid state contactor, Power Solid-State Relay (PSSR)</b>	<p>A solid-state relay that can switch a high level of power, which is why they are called semiconductor contactors or PSSR (Power Solid-State Relays). They are considerably larger than conventional solid-state relays and often have a heat sink, which is needed in order to remove the power loss in the output.</p>		x

EMR = Electromechanical relay  
SSR = Solid-state relay

		for EMR	for SSR
<b>Standardised labelling of connections</b>	<p>Connection designation according to EN 50005: The connections are defined by a two-digit code: A1 and A2 are used for the connections of the input or the coil For inputs of time relays which have connections for triggering the time function (control input), these are designated B1.</p> <p>For the connections at the output, the first number indicates the respective output channel and the second number the function. The following examples are given for a 1-channel output: NO contact: 13, 14 NC contact: 11, 12 CO contact: 11, 12, 14 (connection 11 is the common contact, i.e. the root) For relays with more than one output channel, the first number for the respective contact set is exchanged. For example, for a 2 changeover relay: 11, 12, 14 for the first CO contact and 21, 22, 24 for the second CO contact For outputs of timing relays, the function numbers change from .1 to .5, from .2 to .6 and from .4 to .8. The first CO contact is therefore designated 15, 16 and 18 for timing relays.</p> <p>Connection designation according to IEC 67: Common in the USA. In this case, the connections are numbered consecutively. A relay with 4 CO contacts therefore has the numbers 1 to 14. It should be noted that numbers 11, 12 and 14 appear in both connection marking systems but have different functions. Instead of the coil connection markings A1 and A2, the terminal markings A and B are also commonly used. However, the connection designations according to IEC 67 are being used less and less frequently, which is why they are seen on fewer and fewer relay modules.</p>	x	x
<b>Status indicator (input)</b>	<p>Unless otherwise described, the status indicator for relay modules and solid-state relays indicates the presence of a control voltage at the input. It does not indicate the state of the output and may deviate from the state of the output in the following cases:</p> <ul style="list-style-type: none"> <li>• Welded/defective switching elements</li> <li>• Interference radiation or residual voltages on the control lines</li> </ul> <p>At ambient temperatures &gt; 50°C, the luminosity and service life of the LED may be reduced. The function of other status indicators is described in the respective documentation.</p>	x	x
<b>Storage temperature</b>	The permitted ambient temperature, related to a specific relative humidity level, for which the product should be stored while in a current-free state.	x	x

EMR = Electromechanical relay  
SSR = Solid-state relay

		for EMR	for SSR
<b>Surge voltage category</b>	<p>The overvoltage category of a circuit or an electrical system is numbered conventionally (from I to IV) and is based on limiting the assumed surge voltage values that can occur in a circuit (or electrical system with different mains voltages). The assignment to a particular overvoltage category is dependent on the measures which are used to influence (reduce) the surge voltages.</p> <p>Overvoltage category I</p> <ul style="list-style-type: none"> <li>• Devices that are intended to be connected to the permanent electrical building installation.</li> </ul> <p>The measures for limiting transient surge voltages to the proper level are taken outside of the device. The protective mechanisms can either be in the permanent installation or between the permanent installation and the device.</p> <p>Overvoltage category II</p> <ul style="list-style-type: none"> <li>• Devices that are intended to be connected to the permanent electrical building installation (such as a household appliances or portable tools).</li> </ul> <p>Overvoltage category III</p> <ul style="list-style-type: none"> <li>• Devices that are a part of the permanent installation and other devices where a higher degree of availability is required. This includes the distributor panels, power switches, distribution systems (including cable, busbars, distributor boxes, switches and outlets) that are part of the permanent installation, devices intended for industrial use, and devices that are continually connected to the permanent installation (such as stationary motors).</li> </ul> <p>Overvoltage category IV</p> <ul style="list-style-type: none"> <li>• Devices that are intended to be used on or near the power feed in a building's electrical installation – ranging from the main distribution to the mains power system. This includes electrical meters, surge protection switches and ripple control equipment.</li> </ul>	x	x
<b>Switch-off delay</b>	<p>Typical time interval from switching off the rated control voltage of a switched electromechanical relay and solid-state relay until the first opening or closing of the last output circuit (not including the bounce time). For AC, specifications are valid for 50 Hz unless otherwise indicated. Measured at room temperature (approx. 23 °C) and an only briefly energised input (coil temperature below thermal stability). The switching times are strongly dependent on environmental parameters such as ambient temperature, mounting position, manufacturing tolerances, voltage level of the control signal and the shape of the control signal. Therefore, the values in the application may differ from the data sheet specifications.</p>	x	x

EMR = Electromechanical relay  
SSR = Solid-state relay



		for EMR	for SSR
<b>Switch-on delay</b>	<p>Typical time interval from switching on the rated control voltage of an electromechanical relay and solid-state relay until the first closing or opening of the last output circuit (not including the bounce time).</p> <p>For AC, specifications are valid for 50 Hz unless otherwise indicated. Measured at room temperature (approx. 23 °C) and coil temperature equal to room temperature.</p> <p>The switching times are strongly dependent on environmental parameters such as ambient temperature, mounting position, manufacturing tolerances, voltage level of the control signal and the shape of the control signal. Therefore, the values in the application may differ from the data sheet specifications.</p>	x	x
<b>Switching cycle</b>	Describes the cycle of the switching state of response/switch-on and subsequent reset/switch-off of a relay or solid-state relay.	x	x
<b>Switching voltage AC max.</b> <b>Switching voltage DC max.</b>	Maximum permissible voltage with the standard mains tolerances between the switching contacts before closing and after opening a relay contact.	x	
<b>T</b>			
<b>Time ranges</b>	List of the different adjustable time ranges of a timing relay. Mostly adjustable via rotary switch or dip switch.	x	x
<b>Timing relay, multifunction timing relay</b>	Electromechanical relay modules or solid-state relays that can switch with a time delay thanks to a time switch in the control input. Some timing relays can perform different time functions, which is why they are called multifunction timing relays.	x	x
<b>Type code</b>	The type code explains the composition of the article designation (type name). It allows for a large number of possible variations, but not all possible combinations can be found in the current product line, as some combinations cannot be implemented or some variants may be discontinued. Special versions are available on request to meet customer specifications.	x	x

EMR = Electromechanical relay  
SSR = Solid-state relay

		for EMR	for SSR																																
<p><b>Type of contact</b></p>	<p>The following contact arrangements are specified and described:</p> <ul style="list-style-type: none"> <li>• NO contact: Contact which is closed in the relay's operating position and open in its rest position.</li> <li>• NC contact: Contact which is closed in the relay's rest position and open in its operating position.</li> <li>• CO contact: Contact consisting of an NO contact and an NC contact with a common connection (root). When changing the switch position, first the previously closed contact opens and then the previously opened contact closes.</li> </ul> <p>The following table shows the different designations for the contacts:</p> <table border="1" data-bbox="507 819 914 1014"> <thead> <tr> <th></th> <th>Short description</th> <th>NARM designator</th> <th>Circuit symbol</th> </tr> </thead> <tbody> <tr> <td>Make contact</td> <td>NO</td> <td>SPST-NO</td> <td></td> </tr> <tr> <td>Break contact</td> <td>NC</td> <td>SPST-NC</td> <td></td> </tr> <tr> <td>Changeover contact</td> <td>CO</td> <td>SPDT</td> <td></td> </tr> </tbody> </table> <p>For multiple contact relays, the contacts are designated as in the following examples:</p> <table border="1" data-bbox="507 1122 914 1317"> <thead> <tr> <th>Multiple pole configurations</th> <th>Short description</th> <th>NARM designator</th> <th>Circuit symbol</th> </tr> </thead> <tbody> <tr> <td>2 Make contacts</td> <td>2 NO</td> <td>DPST-NO</td> <td></td> </tr> <tr> <td>3 Break contacts</td> <td>3 NC</td> <td>3PST-NC</td> <td></td> </tr> <tr> <td>4 Changeover contacts</td> <td>4 CO</td> <td>4PDT</td> <td></td> </tr> </tbody> </table> <p><b>Abbreviations:</b> NO: normally open; NC: normally closed; CO: changeover; SPST: single pole, single throw; SPDT: single pole, double throw; DPST: double pole, single throw</p>		Short description	NARM designator	Circuit symbol	Make contact	NO	SPST-NO		Break contact	NC	SPST-NC		Changeover contact	CO	SPDT		Multiple pole configurations	Short description	NARM designator	Circuit symbol	2 Make contacts	2 NO	DPST-NO		3 Break contacts	3 NC	3PST-NC		4 Changeover contacts	4 CO	4PDT		x	x
	Short description	NARM designator	Circuit symbol																																
Make contact	NO	SPST-NO																																	
Break contact	NC	SPST-NC																																	
Changeover contact	CO	SPDT																																	
Multiple pole configurations	Short description	NARM designator	Circuit symbol																																
2 Make contacts	2 NO	DPST-NO																																	
3 Break contacts	3 NC	3PST-NC																																	
4 Changeover contacts	4 CO	4PDT																																	
<p><b>Type of insulation</b></p>	<p>Quality of the insulation system, depending on the design and application conditions:</p> <ul style="list-style-type: none"> <li>• Functional insulation: insulation between live components – necessary so the relay functions properly.</li> <li>• Basic insulation: insulation of live parts to provide basic protection against electrical shock.</li> <li>• Doubled insulation: consisting of a base insulation and additional insulation.</li> <li>• Reinforced insulation: a single "enhanced" insulation of active components, which ensures the same protection against electric shock as doubled insulation. The doubled insulation is composed of a base insulation and an additional insulation; the extra insulation protects against electric shock if the basic insulation fails.</li> </ul>	x	x																																

EMR = Electromechanical relay  
SSR = Solid-state relay

		for EMR	for SSR
<b>U</b>			
<b>Utilisation category according to EN 60947 (mechanical relays)</b>	<p>The contactor standard EN 60947 divides loads into different utilisation categories, thereby making it possible to determine service life values for various applications. This standard is also partly applied to relays. However, users must be aware that even these values are only of limited practical use, as the test loads are often highly inductive and are operated without a protective circuit. More precise information on switching capacity and service life can be made on the basis of concrete application data.</p> <p>Explanation of the most important common categories for relay modules:                      AC1: Non-inductive or only weakly inductive load, e.g. heating elements                      AC14: Small electromagnetic loads (&lt;72VA), e.g. small contactors                      AC15: Electromagnetic loads (&gt;72VA), e.g. power contactors                      DC1: Non-inductive or only weakly inductive load, e.g. heating elements                      DC13: electromagnetic loads, e.g. solenoid valves</p>	x	
<b>V</b>			
<b>Voltage drop at max. load</b>	<p>Voltage drop across the switched output of the solid-state relay, when measured under full load.</p> <p>This is due to the fact that semiconductor switches do not become as low-resistance as electromechanical switches. Therefore, when switched, they have more power loss compared to electromechanical relays.</p>		x
<b>Z</b>			
<b>Zero-voltage switching , zero-cross switching</b>	<p>Solid-state relays with AC outputs such as triacs or thyristors which switch on at the zero crossing of the switching voltage and switch off at the zero crossing of the switching current. For this reason, the switching procedure may be delayed depending on the phase position at the time of switching and on the mains frequency of the switching voltage.</p> <p><b>Signal characteristics of zero cross switching PSSR</b>                      shown at an example with resistive load</p> <p><math>t_{on} \leq 10 \text{ ms}</math>    <math>t_{off} \leq 10 \text{ ms}</math></p>		x

EMR = Electromechanical relay  
 SSR = Solid-state relay

# Index

---

<b>Index</b>	Index Type	X.2
	Index Order No.	X.6
	Addresses worldwide	X.12

---



Type	Order No.	Page
DRM570548L	7760056093	B.155
DRM570548LT	7760056102	B.155
DRM570615	7760056085	B.155
DRM570615L	7760056094	B.155
DRM570615LT	7760056103	B.155
DRM570730	7760056086	B.155
DRM570730L	7760056095	B.155
DRM570730LT	7760056104	B.155
DRMKIT 220VDC 2CD LD	1542370000	C.145
DRMKIT 220VDC 2CD LD/PB	1542470000	C.145
DRMKIT 220VDC 4CD LD	1542420000	C.149
DRMKIT 220VDC 4CD LD/PB	1542520000	C.149
DRMKIT 230VAC 2CD LD	1542390000	C.145
DRMKIT 230VAC 2CD LD/PB	1542490000	C.145
DRMKIT 230VAC 4CD LD	1542450000	C.149
DRMKIT 230VAC 4CD LD/PB	1542540000	C.149
DRMKIT 24VAC 2CD LD	1542380000	C.145
DRMKIT 24VAC 2CD LD/PB	1542480000	C.145
DRMKIT 24VAC 4CD LD	1542430000	C.149
DRMKIT 24VAC 4CD LD/PB	1542530000	C.149
DRMKIT 24VDC 2CD LD	1542360000	C.145
DRMKIT 24VDC 2CD LD/PB	1542460000	C.145
DRMKIT 24VDC 4CD LD	1542410000	C.149
DRMKIT 24VDC 4CD LD/PB	1542510000	C.149
DRMKITP 115VAC 2CD LD	2575990000	C.143
DRMKITP 115VAC 4CD LD	2576010000	C.147
DRMKITP 230VAC 2CD LD	2576030000	C.143
DRMKITP 230VAC 4CD LD	2576050000	C.147
DRMKITP 24VAC 2CD LD	2576070000	C.143
DRMKITP 24VAC 2CD LD/PB	2576080000	C.143
DRMKITP 24VAC 4CD LD	2576090000	C.147
DRMKITP 24VAC 4CD LD/PB	2576100000	C.147
DRMKITP 24VDC 2CD LD	2576110000	C.143
DRMKITP 24VDC 2CD LD/PB	2576120000	C.143
DRMKITP 24VDC 4CD LD	2576130000	C.147
DRMKITP 24VDC 4CD LD/PB	2576140000	C.147
DRMKITP 15VAC 2CD LD	2576000000	C.143
DRMKITP 15VAC 4CD LD/PB	2576020000	C.147
DRMKITP 230VAC 2CD LD/PB	2576040000	C.143
DRMKITP 230VAC 4CD LD/PB	2576060000	C.147
DRR CLIP M	1134160000	C.162
DRR273012L	2765010000	C.159
DRR273024L	2765020000	C.159
DRR273048L	2765030000	C.159
DRR273110L	2765040000	C.159
DRR273220L	2765050000	C.159
DRR273524L	2765310000	C.159
DRR273615L	2765320000	C.159
DRR273730L	2765330000	C.159
DRR373012L	2765060000	C.161
DRR373024L	2765070000	C.161
DRR373048L	2765080000	C.161
DRR373110L	2765090000	C.161
DRR373220L	2765200000	C.161
DRR373524L	2765340000	C.161
DRR373615L	2765350000	C.161
DRR373730L	2765360000	C.161
DRW/DRH CLIP M	1220260000	C.182
DRW/DRH CLIP M	1220260000	C.38
DRW273012LT	2765590000	C.175
DRW273012LT	2765590000	C.31
DRW273024LT	2765600000	C.175
DRW273024LT	2765600000	C.31
DRW273048LT	2765610000	C.175
DRW273048LT	2765610000	C.31
DRW273110LT	2765620000	C.175
DRW273110LT	2765620000	C.31
DRW273220LT	2765630000	C.175
DRW273220LT	2765630000	C.31
DRW273524LT	2765490000	C.175
DRW273524LT	2765490000	C.31
DRW273548LT	2765500000	C.175
DRW273548LT	2765500000	C.31
DRW273615LT	2765510000	C.175
DRW273615LT	2765510000	C.31
DRW273730LT	2765520000	C.175
DRW273730LT	2765520000	C.31
DRW273900LT	2765530000	C.175
DRW273900LT	2765530000	C.31
DRW373012LT	2765640000	C.175
DRW373012LT	2765640000	C.31
DRW373024LT	2765650000	C.175
DRW373024LT	2765650000	C.31
DRW373048LT	2765660000	C.175
DRW373048LT	2765660000	C.31
DRW373110LT	2765670000	C.175
DRW373110LT	2765670000	C.31
DRW373220LT	2765680000	C.175
DRW373220LT	2765680000	C.31
DRW373524LT	2765540000	C.175
DRW373524LT	2765540000	C.31
DRW373548LT	2765550000	C.175
DRW373548LT	2765550000	C.31
DRW373615LT	2765560000	C.175
DRW373615LT	2765560000	C.31
DRW373730LT	2765570000	C.175
DRW373730LT	2765570000	C.31
DRW373900LT	2765580000	C.175
DRW373900LT	2765580000	C.31

Type	Order No.	Page
<b>E</b>		
ESG 6/15 SDI MC NE WS	2558340000	B.136
ESG 6/15 SDI MC NE WS	2558340000	B.140
ESG 9/26 SCM ECO MC NE WS	1520980000	B.152
ESG 9/26 SCM ECO MC NE WS	1520980000	B.156
<b>F</b>		
FS 2CD	7760056106	B.153
FS 4CD	7760056107	B.157
FSKIT 24VDC 2NO2NC FG LD AGSNO AU	2759080000	C.129
FSKIT 24VDC 3NO1NC FG LD AGSNO AU	2759070000	C.129
FSKIT 24VDC 3NO3NC FG LD AGSNO AU	2759100000	C.131
FSKIT 24VDC 4NO2NC FG LD AGSNO AU	2759090000	C.131
FSKIT 24VDC 5NO1NC FG LD AGSNO AU	2860020000	C.131
<b>I</b>		
ISPF QB75 BL	0526780000	C.151
ISPF QB75 RT	0526780000	C.151
ISPF QB75 SW	0526700000	C.151
ITS 24-240VUC 1CD M7C	2496190000	C.106
ITS 24-240VUC M7C PU10	2545120000	C.106
<b>M</b>		
MCZ 0 120VUC	8421060000	B.193
MCZ 0 230VAC	8421380000	B.193
MCZ 0 24VDC	8324610000	B.194
MCZ 0 24VUC	8365940000	B.192
MCZ 0 24VUC	8287730000	B.192
MCZ 0 5VTTL	8398940000	B.194
MCZ 0 TRAK 24.110VDC	8820710000	B.195
MCZ R 110VDC	8467470000	B.187
MCZ R 120VAC	8420880000	B.187
MCZ R 230VAC	8237710000	B.187
MCZ R 24VDC	8365980000	B.187
MCZ R 24VDC 1CD AU TRAK	8790520000	B.189
MCZ R 24VDC 1CD TRAK	8713890000	B.191
MCZ R 24VDC 1NO TRAK	8499550000	B.189
MCZ R 24VDC 5UAU	8442960000	B.187
MCZ R 24VUC	8390590000	B.187
MCZ R 36VDC 1CD AU TRAK	8790510000	B.191
MCZ R 36VDC 1CD TRAK	8713900000	B.189
MCZ R 48...110VDC 1CD AU TRAK	8790500000	B.191
MCZ R 48...110VDC 1CD TRAK	8713910000	B.189
MCZ R 48...110VDC 1NO TRAK	8574070000	B.189
MCZ TO 24VDC/150MS	8286410000	C.110
MCZ TO 24VDC/50MS	8324590000	C.110
MOS 12-28VDC 100KHZ	8937990000	C.62
MOS 12-28VDC/5VTTL	8937930000	C.64
MOS 12-28VDC/5VTTL	8937930000	C.72
MOS 24VDC/12-30VDC 1A	8937830000	C.11
MOS 24VDC/5-33VDC 10A	8937940000	C.10
MOS 24VDC/5-48VDC 0,5A	8937980000	C.10
MOS 24VDC/8-30VDC 2A	8937970000	C.72
MOS 24VDC/8-30VDC 2A E	1283230000	C.13
MOS 5VTTL/24VDC 0,1A	8937920000	C.63
MOS 5VTTL/24VDC 0,1A	8937920000	C.71
MOS FEED THROUGH	8973450000	C.151
MOS SUPPLY	8973460000	C.151
<b>P</b>		
PSSRN K 24VDC 1D K 1000VDC 15A	2986930000	C.143
PSSRN K 24VDC 1Z K 240VAC 20A	2986890000	C.140
PSSRN K 24VDC 1Z K 600VAC 30A	2986900000	C.141
PSSRN K 24VDC 3Z K 600VAC 2A	2986910000	C.144
PSSRN S 24VDC 1M K 600VAC 30A T	2986920000	C.142
PWR173012L	1219470000	C.147
PWR173024L	1219480000	C.147
PWR173048L	1219490000	C.147
PWR173110L	1219500000	C.147
PWR173220L	1219510000	C.147
PWR173524L	1219090000	C.147
PWR173548L	1219120000	C.147
PWR173615L	1219130000	C.147
PWR173730L	1219140000	C.147
PWR173880L	1219150000	C.147
PWR276012L	1219540000	C.149
PWR276024L	1219550000	C.149
PWR276048L	1219560000	C.149
PWR276110L	1219570000	C.149
PWR276220L	1219580000	C.149
PWR276524L	1219160000	C.149
PWR276548L	1219170000	C.149
PWR276615L	1219180000	C.149
PWR276730L	1219190000	C.149
PWR276880L	1219220000	C.149
<b>Q</b>		
QB 75/6 2/15	0535200000	C.151
<b>R</b>		
RCH424024FG	2723360000	B.77
RCH424024FG	2723360000	C.135

Type	Order No.	Page
RCL424005	8693790000	B.98
RCL424012	4058560000	B.98
RCL424024	4058570000	B.98
RCL424048	4058750000	B.98
RCL424060	4058760000	B.98
RCL424110	4058590000	B.98
RCL425005	1174490000	B.98
RCL425012	4074580000	B.98
RCL425024	4058580000	B.98
RCL425048	1201230000	B.98
RCL425060	1201260000	B.98
RCL425110	8828370000	B.98
RIM 1 6/230VDC	7760056169	B.136
RIM 1 6/230VDC	7760056169	B.140
RIM 1 6/230VDC	7760056169	B.152
RIM 1 6/230VDC	7760056169	B.156
RIM 1 6/230VDC	7760056169	B.157
RIM 1 6/230VDC	7760056169	B.172
RIM 1 6/230VDC	7760056169	C.28
RIM 2 110/230VDC	7760056017	B.136
RIM 2 110/230VDC	7760056017	B.140
RIM 2 110/230VDC	7760056017	B.152
RIM 2 110/230VDC	7760056017	B.156
RIM 2 110/230VDC	7760056017	B.157
RIM 2 110/230VDC	7760056017	B.172
RIM 2 110/230VDC	7760056017	C.28
RIM 2 24/60VDC	7760056016	B.136
RIM 2 24/60VDC	7760056016	B.140
RIM 2 24/60VDC	7760056016	B.152
RIM 2 24/60VDC	7760056016	B.156
RIM 2 24/60VDC	7760056016	B.157
RIM 2 24/60VDC	7760056016	B.172
RIM 2 24/60VDC	7760056016	C.28
RIM 2 6/24VDC	7760056015	B.136
RIM 2 6/24VDC	7760056015	B.140
RIM 2 6/24VDC	7760056015	B.152
RIM 2 6/24VDC	7760056015	B.156
RIM 2 6/24VDC	7760056015	B.157
RIM 2 6/24VDC	7760056015	B.172
RIM 2 6/24VDC	7760056015	C.28
RIM 3 110/230VAC	7760056014	B.136
RIM 3 110/230VAC	7760056014	B.140
RIM 3 110/230VAC	7760056014	B.152
RIM 3 110/230VAC	7760056014	B.156
RIM 3 110/230VAC	7760056014	B.157
RIM 3 110/230VAC	7760056014	B.172
RIM 3 110/230VAC	7760056014	C.28
RIM 3 110/230VAC LED	7760056045	B.136
RIM 3 110/230VAC LED	7760056045	B.140
RIM 3 110/230VAC LED	7760056045	B.152
RIM 3 110/230VAC LED	7760056045	B.156
RIM 3 110/230VAC LED	7760056045	B.157
RIM 3 110/230VAC LED	7760056045	B.172
RIM 3 110/230VAC LED	7760056045	C.28
RIM 3 110/230VAC LED	7940018455	B.136
RIM 3 110/230VAC	7940018455	B.140
RIM 3 110/230VAC	7940018455	B.152
RIM 3 110/230VAC	7940018455	B.156
RIM 3 110/230VAC	7940018455	B.157
RIM 3 110/230VAC	7940018455	B.172
RIM 3 110/230VAC	7940018455	C.28
RIM 3 24/60VUC	7760056018	B.136
RIM 3 24/60VUC	7760056018	B.140
RIM 3 24/60VUC	7760056018	B.152
RIM 3 24/60VUC	7760056018	B.156
RIM 3 24/60VUC	7760056018	B.157
RIM 3 24/60VUC	7760056018	B.172
RIM 3 24/60VUC	7760056018	C.28
RIM 5 6/230VAC	1174670000	B.162
RIM 5 6/230VAC	1174670000	B.173
RIM 5 6/230VAC	1174670000	B.182
RIM 5 6/230VAC	1174670000	C.29
RIM 5 6/230VAC	1174670000	C.38
RIM 5 6/230VDC	1174650000	B.162
RIM 5 6/230VDC	1174650000	B.173
RIM 5 6/230VDC	1174650000	B.182
RIM 5 6/230VDC	1174650000	C.29
RIM 5 6/230VDC	1174650000	C.38
RSS110005	1984100000	B.98
RSS110012	1984110000	B.98
RSS110024	1984090000	B.98
RSS110060	1984120000	B.98
RSS11024T	2851620000	B.98
RSS112005	1174540000	B.98
RSS112012	1220670000	B.98
RSS112024	4061590000	B.98
RSS112060	4061600000	B.98
RSS113005	4061580000	B.98
RSS113012	4061610000	B.98
RSS113024	4060120000	B.

Type	Order No.	Page	Type	Order No.	Page	Type	Order No.	Page	Type	Order No.	Page
SPW ECO 3CD	1220250000	C.38	TOP 230VAC/48VDC 0,5A	8951090000	C.45	TOS 12VDC 24VDC2A	1127150000	C.77	TRP 120VAC RC 1CD AU	2618030000	B.35
SRC1 QV S	1132070000	B.136	TOP 230VAC/48VDC 0,5A RC	1182600000	C.48	TOS 12VDC 48VDC0,1A	1126930000	B.79	TRP 120VAC RC 1CD AU	2618030000	C.51
SRC1 QV S	1132070000	B.140	TOP 230VAC 230VAC1A	2618450000	C.87	TOS 12VDC 48VDC0,1A	1126930000	C.57	TRP 120VAC RC 1CD AU	2618030000	C.83
SRD ECO 2CD	1132810000	B.162	TOP 230VAC 230VAC1A	2618450000	B.79	TOS 12VDC 48VDC0,1A	1126930000	C.75	TRP 120VAC RC 1CD EMPTY	2618880000	B.100
SRD ECO 3CD	1132820000	B.162	TOP 230VAC 24VDC2A	2618800000	C.83	TOS 12VDC/230VAC 0,1A	8951110000	C.47	TRP 120VAC RC 2CD	2618470000	B.63
SSR 10-230VDC/0-35VDC 5A	1421450000	B.99	TOP 230VAC 24VDC2A	2618800000	B.77	TOS 12VDC/230VAC 0,1A	8951110000	C.67	TRP 120VAC RC 2CD	2618470000	C.87
SSR 24VDC/0-24VDC 3,5A	1132310000	B.99	TOP 230VAC 48VDC0,1A	2618690000	B.79	TOS 12VDC/48VDC 0,1A	8950710000	C.43	TRP 120VAC RC 2CD AU	2618490000	B.67
SSR 24VDC/MAX 240VAC 1A	1132290000	B.99	TOP 230VAC 48VDC0,1A	2618690000	C.57	TOS 12VDC/48VDC 0,5A	8950910000	C.45	TRP 120VAC RC 2CD AU	2618490000	C.55
SSS RELAIS 24V/230V 1AAC	4061210000	B.99	TOP 230VAC 48VDC0,1A	2618690000	C.75	TOS 220VDC/230VAC 0,1A	8951150000	C.47	TRP 120VAC RC 2CD AU	2618490000	C.89
SSS RELAIS 24V/24V 0,1ADC	4061180000	B.99	TOP 24-230VAC 230VAC1A ED2	2663090000	B.88	TOS 220VDC/48VDC 0,1A	8950750000	C.43	TRP 120VAC RC 2CD EMPTY	2681030000	B.101
SSS RELAIS 24V/24V 2ADC	4061190000	B.99	TOP 24-230VAC 24VDC2A ED2	2663080000	B.84	TOS 220VDC/48VDC 0,5A	8950950000	C.45	TRP 120VAC 1CD	2618010000	B.33
SSS RELAIS 5V/230V 1AAC	1132280000	B.99	TOP 24-230VAC 24VDC3,5A ED2	2663100000	B.90	TOS 230VAC RC 230VAC1A	1127490000	B.87	TRP 120VAC 1CD	2618010000	C.81
SSS RELAIS 5V/24V 0,1ADC	4064320000	B.99	TOP 24-230VAC 24VDC5A ED2	2663150000	B.91	TOS 230VAC RC 230VAC1A	1127490000	C.79	TRP 120VAC 1CD 16A	2618280000	B.57
SSS RELAIS 5V/24V 2ADC	4064310000	B.99	TOP 24-230VAC 48VDC0,1A ED2	2663070000	B.80	TOS 230VAC RC 24VDC2A	1127240000	B.83	TRP 120VAC 1CD 16A PB	2988310000	B.51
SSS RELAIS 60V/230V 1AAC	4061220000	B.99	TOP 24-230VAC 48VDC0,1A ED2	2663070000	C.58	TOS 230VAC RC 24VDC2A	1127400000	C.77	TRP 120VAC 1CD AGSNO	2617900000	B.39
SSS RELAIS 60V/24V 0,1ADC	4061230000	B.99	TOP 24-230VAC EMPTY ED2	2663100000	B.101	TOS 230VAC RC 48VDC0,1A	1127010000	B.79	TRP 120VAC 1CD AGSNO	2617900000	C.85
SSS RELAIS 60V/24V 2ADC	4061200000	B.99	TOP 24VAC/230VAC 0,1A	8951260000	C.47	TOS 230VAC RC 48VDC0,1A	1127010000	C.57	TRP 120VAC 1CD AU	2618080000	B.35
			TOP 24VAC/48VDC 0,1A	8950860000	C.43	TOS 230VAC RC 48VDC0,1A	1127010000	C.75	TRP 120VAC 1CD AU	2618080000	C.51
			TOP 24VAC/48VDC 0,5A	8951060000	C.45	TOS 230VAC/230VAC 0,1A	8951250000	C.47	TRP 120VAC 1CD AU	2618080000	C.83
			TOP 24VDC 230VAC1A	2618420000	B.87	TOS 230VAC/48VDC 0,1A	8950850000	C.43	TRP 120VAC 1CD EMPTY	2618950000	B.100
			TOP 24VDC 230VAC1A	2618420000	C.79	TOS 230VAC/48VDC 0,5A	8951050000	C.45	TRP 120VAC 2CD	2618570000	B.63
			TOP 24VDC 24VDC2A	2618720000	B.83	TOS 230VAC/48VDC 0,5A RC	1189270000	C.48	TRP 120VAC 2CD	2618570000	C.87
			TOP 24VDC 24VDC2A	2618720000	C.77	TOS 230VAC/48VDC 0,5A RC	1127470000	B.87	TRP 120VAC 2CD AU	2618590000	B.67
			TOP 24VDC 24VDC3,5A	2618700000	B.90	TOS 230VAC 230VAC1A	1127470000	C.79	TRP 120VAC 2CD AU	2618590000	C.55
			TOP 24VDC 24VDC5A	2618840000	B.91	TOS 230VAC 24VDC2A	1127220000	B.83	TRP 120VAC 2CD AU	2618590000	C.89
			TOP 24-230VAC 48VDC0,1A ED2	2618790000	B.79	TOS 230VAC 24VDC2A	1127220000	C.77	TRP 120VAC 2CD EMPTY	2681010000	B.101
			TOP 24VDC 48VDC0,1A	2618790000	C.57	TOS 230VAC 48VDC0,1A	1126990000	B.79	TRP 120VAC 2CD PB	2988360000	B.71
			TOP 24-230VAC 48VDC0,1A	2618790000	C.75	TOS 230VAC 48VDC0,1A	1126990000	C.57	TRP 12VDC 1CD	2618180000	B.33
			TOP 24VDC ACT	2618750000	C.85	TOS 230VAC 48VDC0,1A	1126990000	C.75	TRP 12VDC 1CD	2618180000	C.81
			TOP 24VDC ACT	2618750000	B.119	TOS 24-230VAC 230VAC1A ED2	2662930000	B.88	TRP 12VDC 1CD 16A	2618040000	B.57
			TOP 24VDC EMPTY	2618740000	B.101	TOS 24-230VAC 24VDC2A ED2	2662920000	B.84	TRP 12VDC 1CD AGSNO	2617860000	B.39
			TOP 24VDC/230VAC 0,1A	8951180000	C.47	TOS 24-230VAC 24VDC3,5A ED2	2662940000	B.90	TRP 12VDC 1CD AGSNO	2617860000	C.85
			TOP 24VDC/230VAC 0,1A	8951180000	C.67	TOS 24-230VAC 24VDC5A ED2	2662990000	B.91	TRP 12VDC 1CD AU	2618120000	B.35
			TOP 24VDC/24VDC 4A	1254880000	C.14	TOS 24-230VAC 48VDC0,1A ED2	2662910000	B.80	TRP 12VDC 1CD AU	2618120000	C.51
			TOP 24VDC/48VDC 0,1A	8951070000	C.43	TOS 24-230VAC 48VDC0,1A ED2	2662910000	C.58	TRP 12VDC 1CD AU	2618120000	C.83
			TOP 24VDC/48VDC 0,5A	8950980000	C.45	TOS 24-230VAC EMPTY ED2	2662950000	B.101	TRP 12VDC 1CD EMPTY	2618930000	B.100
			TOP 24VDC 230VAC1A	2618350000	B.87	TOS 24VAC/230VAC 0,1A	8951220000	C.47	TRP 12VDC 2CD	2618550000	B.63
			TOP 24VDC 230VAC1A	2618350000	C.79	TOS 24VAC/48VDC 0,1A	8950820000	C.43	TRP 12VDC 2CD	2618550000	C.87
			TOP 24VDC 24VDC2A	2618730000	B.83	TOS 24VAC/48VDC 0,5A	8951020000	C.45	TRP 12VDC 2CD AU	2618310000	B.67
			TOP 24VDC 24VDC2A	2618730000	C.77	TOS 24VDC 230VAC1A	1127410000	B.87	TRP 12VDC 2CD AU	2618310000	C.55
			TOP 24VDC 48VDC0,1A	2618640000	B.79	TOS 24VDC 230VAC1A	1127410000	C.79	TRP 12VDC 2CD AU	2618310000	C.89
			TOP 24VDC 48VDC0,1A	2618640000	C.57	TOS 24VDC 24VDC2A	1127170000	B.83	TRP 12VDC 2CD EMPTY	2680960000	B.101
			TOP 24VDC 48VDC0,1A	2618640000	B.79	TOS 24VDC 24VDC2A	1127170000	C.77	TRP 230VAC RC 1CD	2618200000	B.33
			TOP 24VDC 48VDC0,1A	2618640000	C.75	TOS 24VDC 24VDC3,5A	1127630000	B.90	TRP 230VAC RC 1CD	2618200000	C.81
			TOP 48-60VAC/230VAC 0,1A	8951270000	C.47	TOS 24VDC 24VDC5A	1127630000	B.91	TRP 230VAC RC 1CD 16A	2618190000	B.57
			TOP 48-60VAC/48VDC 0,1A	8950870000	C.43	TOS 24VDC 24VDC5A	1990960000	B.91	TRP 230VAC RC 1CD AGSNO	2617850000	B.39
			TOP 48-60VAC/48VDC 0,5A	8951070000	C.45	TOS 24VDC 48VDC0,1A	1126940000	B.79	TRP 230VAC RC 1CD AGSNO	2617850000	C.85
			TOP 48-60VDC/230VAC 0,1A	8951190000	C.47	TOS 24VDC 48VDC0,1A	1126940000	C.57	TRP 230VAC RC 1CD AU	2617950000	B.35
			TOP 48-60VDC/48VDC 0,1A	8950790000	C.43	TOS 24VDC 48VDC0,1A	1126940000	C.75	TRP 230VAC RC 1CD AU	2617950000	C.51
			TOP 48-60VDC/48VDC 0,5A	8950980000	C.45	TOS 24VDC ACT	1391680000	C.19	TRP 230VAC RC 1CD AU	2617950000	C.83
			TOP 48VDC 230VAC1A	2618460000	B.87	TOS 24VDC ACT	1391680000	C.19	TRP 230VAC RC 1CD AU	2617950000	C.89
			TOP 48VDC 230VAC1A	2618460000	C.79	TOS 24VDC EMPTY	1127270000	B.101	TRP 230VAC RC 1CD EMPTY	2618890000	B.100
			TOP 48VDC 24VDC2A	2618760000	B.83	TOS 24VDC/230VAC 0,1A	8951120000	C.47	TRP 230VAC RC 2CD	2618330000	B.63
			TOP 48VDC 24VDC2A	2618760000	C.77	TOS 24VDC/230VAC 0,1A	8951120000	C.67	TRP 230VAC RC 2CD	2618330000	C.87
			TOP 48VDC 48VDC0,1A	2618710000	B.79	TOS 24VDC/24VDC 4A	1275100000	C.14	TRP 230VAC RC 2CD AU	2618500000	B.67
			TOP 48VDC 48VDC0,1A	2618710000	C.57	TOS 24VDC/48VDC 0,1A	8950720000	C.43	TRP 230VAC RC 2CD AU	2618500000	C.55
			TOP 48VDC 48VDC0,1A	2618710000	C.75	TOS 24VDC/48VDC 0,5A	8950920000	C.45	TRP 230VAC RC 2CD AU	2618500000	C.89
			TOP 5VDC 230VAC1A	2614850000	C.45	TOS 24VDC/48VDC 0,5A	8950920000	C.45	TRP 230VAC RC 2CD EMPTY	2681190000	B.101
			TOP 5VDC 24VDC2A	2618810000	B.79	TOS 24VDC 230VAC1A	1127420000	C.79	TRP 230VAC 1CD	2618050000	B.33
			TOP 5VDC 24VDC2A	2618810000	C.83	TOS 24VDC 24VDC2A	1127180000	B.83	TRP 230VAC 1CD	2618050000	C.81
			TOP 5VDC 24VDC2A	2618810000	C.77	TOS 24VDC 24VDC2A	1127180000	C.77	TRP 230VAC 1CD 16A	2618260000	B.57
			TOP 5VDC 48VDC0,1A	2614860000	B.83	TOS 24VDC 48VDC0,1A	1126950000	B.79	TRP 230VAC 1CD 16A PB	2988320000	B.51
			TOP 5VDC 48VDC0,1A	2614860000	C.57	TOS 24VDC 48VDC0,1A	1126950000	C.57	TRP 230VAC 1CD AGSNO	2617830000	B.39
			TOP 5VDC 48VDC0,1A	2614860000	C.75	TOS 24VDC 48VDC0,1A	1126950000	C.75	TRP 230VAC 1CD AGSNO	2617830000	C.85
			TOP 5VDC/230VAC 0,1A	8951160000	C.47	TOS 48-60VAC/230VAC 0,1A	8951230000	C.45	TRP 230VAC 1CD	2618210000	B.35
			TOP 5VDC/230VAC 0,1A	8951160000	C.75	TOS 48-60VAC/48VDC 0,1A	8950830000	C.43	TRP 230VAC 1CD	2618210000	C.51
			TOP 5VDC/48VDC 0,1A	8950760000	C.63	TOS 48-60VAC/48VDC 0,5A	8951030000	C.45	TRP 230VAC 1CD AU	2618210000	C.83
			TOP 5VDC/48VDC 0,5A	8950980000	C.45	TOS 48-60VDC/230VAC 0,1A	8951130000	C.47	TRP 230VAC 1CD EMPTY	2618960000	B.100
			TOP 60VDC 230VAC1A	2618370000	B.87	TOS 48-60VDC/48VDC 0,1A	8950730000	C.43	TRP 230VAC 2CD	2618440000	B.63
			TOP 60VDC 230VAC1A	2618370000	C.79	TOS 48-60VDC/48VDC 0,5A	8950930000	C.45	TRP 230VAC 2CD	2618440000	C.87
			TOP 60VDC 24VDC2A	2618970000	B.83	TOS 48VDC 230VAC1A	1127430000	B.87	TRP 230VAC 2CD AU	2618300000	B.67
			TOP 60VDC 24VDC2A	2618970000	C.77	TOS 48VDC 230VAC1A	1127430000	C.79	TRP 230VAC 2CD AU	2618300000	C.55
			TOP 60VDC 48VDC0,1A	2614880000	B.79	TOS 48VDC 24VDC2A	1127190000	B.83	TRP 230VAC 2CD AU	2618300000	C.89
			TOP 60VDC 48VDC0,1A	2614880000	C.57	TOS 48VDC 24VDC2A	1127190000	C.77	TRP 230VAC 2CD EMPTY	2681020000	B.101
			TOP 60VDC 48VDC0,1A	2614880000	C.75	TOS 48VDC 48VDC0,1A	1126960000	C.57	TRP 230VAC 2CD PB	2988370000	B.71
			TOP 60VDC 48VDC0,1A	2614880000	B.29	TOS 48VDC 48VDC0,1A	1126960000	C.57	TRP 24-230VAC 1CD 16A ED2	2663120000	B.58
			TOP 60VDC 48VDC0,1A	2614880000	C.43	TOS 48VDC 48VDC0,1A	1126960000	C.75	TRP 24-230VAC 1CD 16A ED2 PB	2988330000	B.52
			TOP 60VDC 48VDC0,1A	2614880000	C.79	TOS 5VDC 230VAC1A	1127390000	B.87	TRP 24-230VAC 1CD AGSNO AU ED2 PB	2955900000	B.48
			TOP 60VDC 48VDC0,1A	2614880000	C.45	TOS 5VDC 230VAC1A	1127390000	C.79	TRP 24-230VAC 1CD AGSNO ED2	2663160000	B.40
			TOP 60VDC 48VDC0,1A	2614880000	C.79	TOS 5VDC 24VDC2A	1127140000	B.83	TRP 24-230VAC 1CD AGSNO ED2 PB	2855910000	B.44
			TOP 60VDC 48VDC0,1A	2614880000	C.87	TOS 5VDC 24VDC2A	1127140000	C.77	TRP 24-230VAC 1CD AU ED2	2663020000	B.3

Type	Order No.	Page	Type	Order No.	Page	Type	Order No.	Page	Type	Order No.	Page
TRP 24VDC 1CD AGSNO PB	2855800000	B.43	TRPL 24-230VDC 1CD	2773860000	B.8	TRS 230VDC 2CD AU	1123790000	C.55	TRS 5VDC 2CD	1123470000	B.63
TRP 24VDC 1CD AU	2618110000	B.35	TRPL 24-230VDC 1ND	2773870000	B.12	TRS 230VDC 2CD AU	1123790000	C.89	TRS 5VDC 2CD	1123470000	C.87
TRP 24VDC 1CD AU	2618110000	C.51	TRPL 24-230VDC 2CD	2773880000	B.6	TRS 230VDC 2CD EMPTY	1124030000	B.101	TRS 5VDC 2CD AU	1123710000	B.67
TRP 24VDC 1CD AU	2618110000	C.83	TRPL 24-230VDC 1CD	2773890000	B.17	TRS 230VDC 2CD PB	2988470000	B.71	TRS 5VDC 2CD AU	1123710000	C.55
TRP 24VDC 1CD EMPTY	2618870000	B.100	TRPL 24VDC 1CD AU TRAK	2773900000	B.25	TRS 24-230VDC 1CD 16A ED2	2662960000	B.58	TRS 5VDC 2CD AU	1123710000	C.89
TRP 24VDC 1NO HC	2618090000	B.60	TRPL 24VDC 1CD TRAK	2773910000	B.23	TRS 24-230VDC 1CD 16A ED2 PB	2988430000	B.52	TRS 5VDC 2CD EMPTY	1123950000	B.101
TRP 24VDC 1NO HC	2618090000	C.16	TRPL 24VDC 1NO	2773920000	B.11	TRS 24-230VDC 1CD AGSNO AU ED2 PB	2855920000	B.48	TRS 60VDC 1CD	1122800000	B.33
TRP 24VDC 1NO HCP	2617930000	B.61	TRPL 24VDC 1NO F	2773930000	B.19	TRS 24-230VDC 1CD AGSNO ED2	2663000000	B.40	TRS 60VDC 1CD	1122800000	C.81
TRP 24VDC 1NO HCP	2617930000	C.17	TRPL 24VDC 1NO TRAK	2773940000	B.27	TRS 24-230VDC 1CD AGSNO ED2 PB	2855930000	B.44	TRS 60VDC 1CD 16A	1479710000	B.57
TRP 24VDC 2CD	2618400000	B.63	TRPL 24VDC 2CD	2773960000	B.15	TRS 24-230VDC 1CD AU ED2	2662860000	B.37	TRS 60VDC 1CD AGSNO	2153550000	B.39
TRP 24VDC 2CD	2618400000	C.87	TRPL 24VDC 1CD	2773970000	B.7	TRS 24-230VDC 1CD AU ED2	2662860000	C.52	TRS 60VDC 1CD AGSNO	2153550000	C.85
TRP 24VDC 2CD AU	2618530000	C.67	TRPL 24VDC 1NO	2773980000	B.11	TRS 24-230VDC 1CD C1D2	1984610000	B.93	TRS 60VDC 1CD AU	1123030000	B.35
TRP 24VDC 2CD AU	2618530000	B.55	TRPL 24VDC 2CD	2773990000	B.15	TRS 24-230VDC 1CD ED2	2662850000	B.36	TRS 60VDC 1CD AU	1123030000	C.51
TRP 24VDC 2CD AU	2618530000	C.89	TRPL 48-110VDC 1CD AU TRAK	2774000000	B.25	TRS 24-230VDC 1CD EMPTY ED2	2662870000	B.100	TRS 60VDC 1CD AU	1123030000	C.83
TRP 24VDC 2CD EMPTY	2680970000	B.101	TRPL 48-110VDC 1CD TRAK	2774010000	B.23	TRS 24-230VDC 1COAUC1D2	1984650000	B.95	TRS 60VDC 1CD EMPTY	1123280000	B.100
TRP 24VDC 2CD PB	2988340000	B.71	TRPL 48-110VDC 1NO TRAK	2774020000	B.27	TRS 24-230VDC 1NO HC ED2	2662970000	B.60	TRS 60VDC 2CD	1123520000	B.63
TRP 24VDC ACT	2618230000	B.54	TRPL 5VDC 1CD	2774030000	B.7	TRS 24-230VDC 1NO HC ED2	2662970000	C.16	TRS 60VDC 2CD	1123520000	C.87
TRP 24VDC ACT	2618230000	C.18	TRPL 5VDC 1NO	2774040000	B.11	TRS 24-230VDC 1NO HCP ED2	2662980000	B.61	TRS 60VDC 2CD AU	1123770000	B.67
TRP 24VDC ACT PB	2855840000	B.54	TRPL 5VDC 2CD	2774050000	B.15	TRS 24-230VDC 1NO HCP ED2	2662980000	C.17	TRS 60VDC 2CD AU	1123770000	C.55
TRP 24VDC ACT PB	2855840000	C.18	TRS 120VAC RC 1CD	1122830000	B.33	TRS 24-230VDC 2CD AU ED2	2662890000	B.68	TRS 60VDC 2CD AU	1123770000	C.89
TRP 24VDC 1CD	2618220000	B.33	TRS 120VAC RC 1CD	1122830000	C.81	TRS 24-230VDC 2CD AU ED2	2662890000	C.53	TRS 60VDC 2CD EMPTY	1124010000	B.101
TRP 24VDC 1CD	2618220000	C.81	TRS 120VAC RC 1CD 16A	1479750000	B.57	TRS 24-230VDC 2CD ED2	2662880000	B.64	TRS T 24VDC 1CD M3	2639560000	B.74
TRP 24VDC 1CD 16A	2617910000	C.87	TRS 120VAC RC 1CD AGSNO	2152900000	B.39	TRS 24-230VDC 2CD ED2 PB	2988480000	B.72	TRS T 24VDC 1CD M3	2639560000	C.94
TRP 24VDC 1CD 16A PB	2988300000	B.51	TRS 120VAC RC 1CD AGSNO	2152900000	C.85	TRS 24-230VDC 2CD EMPTY ED2	2662900000	B.101	TRS T 24VDC 1CD M3 EMPTY	2639720000	B.75
TRP 24VDC 1CD AGSNO	2617880000	B.39	TRS 120VAC RC 1CD AU	1123070000	C.35	TRS 24VDC 1CD	1122770000	B.33	TRS T 24VDC 1CD M3 EMPTY	2639720000	C.95
TRP 24VDC 1CD AGSNO	2617880000	C.89	TRS 120VAC RC 1CD AU	1123070000	C.51	TRS 24VDC 1CD	1122770000	C.81	TW TXS/TXZ R3.2	1240800000	B.103
TRP 24VDC 1CD AGSNO AU PB	2855820000	B.47	TRS 120VAC RC 1CD AU	1123070000	C.83	TRS 24VDC 1CD 16A	1479680000	B.57	TXL PB	2774090000	B.103
TRP 24VDC 1CD AGSNO PB	2855810000	B.43	TRS 120VAC RC 1CD EMPTY	1123310000	B.100	TRS 24VDC 1CD 16A PB	2988390000	B.51	TXP SUPPLY	2618940000	B.102
TRP 24VDC 1CD AU	2618160000	B.35	TRS 120VAC RC 2CD	1123550000	B.63	TRS 24VDC 1CD AGSNO	1984540000	B.39	TXPL FT	2774080000	B.102
TRP 24VDC 1CD AU	2618160000	C.51	TRS 120VAC RC 2CD	1123550000	C.87	TRS 24VDC 1CD AGSNO	1984540000	C.85	TXPL S	2774100000	B.102
TRP 24VDC 1CD AU	2618160000	C.83	TRS 120VAC RC 2CD AU	1123800000	B.67	TRS 24VDC 1CD AGSNO AU PB	2855860000	B.47	TXS SUPPLY	1240780000	B.102
TRP 24VDC 1CD EMPTY	2618910000	B.100	TRS 120VAC RC 2CD AU	1123800000	C.55	TRS 24VDC 1CD AGSNO PB	2855870000	B.43			
TRP 24VDC 2CD	2618320000	B.63	TRS 120VAC RC 2CD AU	1123800000	C.89	TRS 24VDC 1CD AU	1123000000	B.36			
TRP 24VDC 2CD	2618320000	C.87	TRS 120VAC RC 2CD EMPTY	1124040000	B.101	TRS 24VDC 1CD AU	1123000000	C.51			
TRP 24VDC 2CD AU	2618540000	B.67	TRS 120VACRC 1CD C1D2	1984590000	B.93	TRS 24VDC 1CD AU	1123000000	C.83			
TRP 24VDC 2CD AU	2618540000	C.55	TRS 120VACRC 1COAU C1D2	1984640000	B.95	TRS 24VDC 1CD C1D2	1984570000	B.93			
TRP 24VDC 2CD AU	2618540000	C.89	TRS 120VDC 2CD	1123530000	B.63	TRS 24VDC 1CD C1D2	1123240000	B.100			
TRP 24VDC 2CD EMPTY	2680980000	B.101	TRS 120VDC 2CD	1123530000	C.87	TRS 24VDC 1COAU C1D2	1984630000	B.95			
TRP 24VDC 2CD FG	2706430000	B.77	TRS 120VDC 1CD	1122810000	C.33	TRS 24VDC 1NO HC	1479780000	B.60			
TRP 24VDC 2CD FG	2706430000	C.135	TRS 120VDC 1CD	1122810000	B.81	TRS 24VDC 1NO HC	1479780000	C.16			
TRP 24VDC 2CD PB	2988350000	B.71	TRS 120VDC 1CD 16A	1479730000	B.57	TRS 24VDC 1NO HCP	1479810000	B.61			
TRP 48VDC 1CD	2618240000	B.33	TRS 120VDC 1CD 16A PB	2988410000	B.51	TRS 24VDC 1NO HCP	1479810000	C.17			
TRP 48VDC 1CD	2618240000	C.81	TRS 120VDC 1CD AGSNO	2153570000	B.39	TRS 24VDC 2CD	1123490000	B.63			
TRP 48VDC 1CD 16A	2617960000	B.57	TRS 120VDC 1CD AGSNO	2153570000	C.85	TRS 24VDC 2CD	1123490000	C.87			
TRP 48VDC 1CD AGSNO	2617890000	B.39	TRS 120VDC 1CD AU	1123040000	B.35	TRS 24VDC 2CD AU	1123730000	B.67			
TRP 48VDC 1CD AGSNO	2617890000	C.85	TRS 120VDC 1CD AU	1123040000	C.51	TRS 24VDC 2CD AU	1123730000	C.55			
TRP 48VDC 1CD AU	2618170000	B.35	TRS 120VDC 1CD AU	1123040000	C.83	TRS 24VDC 2CD AU	1123730000	C.89			
TRP 48VDC 1CD AU	2618170000	C.51	TRS 120VDC 1CD EMPTY	1123290000	B.100	TRS 24VDC 2CD EMPTY	1123980000	B.101			
TRP 48VDC 1CD AU	2618170000	C.83	TRS 120VDC 2CD	1123780000	B.67	TRS 24VDC 2CD PB	2988440000	B.71			
TRP 48VDC 1CD EMPTY	2618920000	B.100	TRS 120VDC 2CD AU	1123780000	C.55	TRS 24VDC ACT	1381900000	B.54			
TRP 48VDC 2CD	2618520000	B.63	TRS 120VDC 2CD AU	1123780000	C.89	TRS 24VDC ACT	1381900000	C.18			
TRP 48VDC 2CD	2618520000	C.87	TRS 1240VDC 2CD EMPTY	1124020000	B.101	TRS 24VDC ACT PB	2855850000	B.54			
TRP 48VDC 2CD AU	2618560000	B.67	TRS 120VDC 2CD PB	2988460000	B.71	TRS 24VDC ACT PB	2855850000	C.18			
TRP 48VDC 2CD AU	2618560000	C.55	TRS 12VDC 1CD	1122750000	B.33	TRS 24VDC 1CD	1122780000	B.33			
TRP 48VDC 2CD AU	2618560000	C.89	TRS 12VDC 1CD	1122750000	C.81	TRS 24VDC 1CD	1122780000	C.81			
TRP 48VDC 2CD EMPTY	2680990000	B.101	TRS 12VDC 1CD 16A	1479670000	B.57	TRS 24VDC 1CD 16A	1479690000	B.57			
TRP 5VDC 1CD	2614830000	B.33	TRS 12VDC 1CD AGSNO	2152880000	B.39	TRS 24VDC 1CD 16A PB	2988400000	B.51			
TRP 5VDC 1CD	2614830000	C.81	TRS 12VDC 1CD AGSNO	2152880000	C.85	TRS 24VDC 1CD AGSNO	2152940000	B.39			
TRP 5VDC 1CD 16A	2618130000	B.57	TRS 12VDC 1CD AU	1122990000	B.35	TRS 24VDC 1CD AGSNO	2152940000	C.85			
TRP 5VDC 1CD AGSNO	2614820000	B.39	TRS 12VDC 1CD AU	1122990000	C.51	TRS 24VDC 1CD AGSNO AU PB	2855880000	B.47			
TRP 5VDC 1CD AGSNO	2614820000	C.85	TRS 12VDC 1CD AU	1122990000	C.83	TRS 24VDC 1CD AGSNO PB	2855890000	B.43			
TRP 5VDC 1CD AU	2618060000	B.35	TRS 12VDC 1CD C1D2	1984560000	B.93	TRS 24VDC 1CD AU	1123010000	B.35			
TRP 5VDC 1CD AU	2618060000	C.51	TRS 12VDC 1CD EMPTY	1123230000	B.100	TRS 24VDC 1CD AU	1123010000	C.51			
TRP 5VDC 1CD AU	2618060000	C.83	TRS 12VDC 1COAU C1D2	1984620000	B.95	TRS 24VDC 1CD AU	1123010000	C.83			
TRP 5VDC 1CD EMPTY	2614870000	B.100	TRS 12VDC 2CD	1123480000	B.63	TRS 24VDC 1CD C1D2	1984580000	B.93			
TRP 5VDC 2CD	2614840000	B.63	TRS 12VDC 2CD	1123480000	C.87	TRS 24VDC 1CD EMPTY	1123250000	B.100			
TRP 5VDC 2CD	2614840000	C.67	TRS 12VDC 2CD AU	1123720000	B.67	TRS 24VDC 2CD	1123500000	C.67			
TRP 5VDC 2CD AU	2618580000	B.67	TRS 12VDC 2CD AU	1123720000	C.55	TRS 24VDC 2CD	1123500000	C.83			
TRP 5VDC 2CD AU	2618580000	C.55	TRS 12VDC 2CD AU	1123720000	C.89	TRS 24VDC 2CD AU	1123740000	B.67			
TRP 5VDC 2CD AU	2618580000	C.89	TRS 12VDC 2CD EMPTY	1123970000	B.101	TRS 24VDC 2CD AU	1123740000	C.55			
TRP 5VDC 2CD EMPTY	2680850000	B.101	TRS 230VAC RC 1CD	1122840000	B.33	TRS 24VDC 2CD AU	1123740000	C.89			
TRP 60VDC 1CD	2618140000	B.33	TRS 230VAC RC 1CD	1122840000	C.81	TRS 24VDC 2CD EMPTY	1123990000	B.101			
TRP 60VDC 1CD	2618140000	C.61	TRS 230VAC RC 1CD 16A	1479780000	B.57	TRS 24VDC 2CD FG	2706290000	B.77			
TRP 60VDC 1CD 16A	2617970000	B.57	TRS 230VAC RC 1CD AGSNO	2152920000	B.39	TRS 24VDC 2CD FG	2706290000	C.135			
TRP 60VDC 1CD AGSNO	2617870000	B.39	TRS 230VAC RC 1CD AGSNO	2152920000	C.85	TRS 24VDC 2CD PB	2988450000	B.71			
TRP 60VDC 1CD AGSNO	2617870000	C.85	TRS 230VAC RC 1CD AU	1123080000	B.35	TRS 48VDC 1CD	1122790000	B.33			
TRP 60VDC 1CD AU	2618070000	B.35	TRS 230VAC RC 1CD AU	1123080000	C.51	TRS 48VDC 1CD	1122790000	C.81			
TRP 60VDC 1CD AU	2618070000	C.51	TRS 230VAC RC 1CD AU	1123080000	C.83	TRS 48VDC 1CD 16A	1479700000	B.57			
TRP 60VDC 1CD AU	2618070000	C.83	TRS 230VAC RC 1CD EMPTY	1123320000	B.100	TRS 48VDC 1CD AGSNO	2153060000	B.39			
TRP 60VDC 1CD EMPTY	2618900000	B.100	TRS 230VAC RC 2CD	1123570000	B.63	TRS 48VDC 1CD AGSNO	2153060000	C.85			
TRP 60VDC 2CD	2618290000	B.63	TRS 230VAC RC 2CD	1123570000	C.87	TRS 48VDC 1CD AU	1123020000	B.35			
TRP 60VDC 2CD	2618290000	C.87	TRS 230VAC RC 2CD AU	1123810000	B.67	TRS 48VDC 1CD AU	1123020000	C.51			
TRP 60VDC 2CD AU	2618360000	B.67	TRS 230VAC RC 2CD AU	1123810000	C.55	TRS 48VDC 1CD AU	1123020000	C.83			
TRP 60VDC 2CD AU	2618360000	C.55	TRS 230VAC RC 2CD AU	1123810000	C.89	TRS 48VDC 1CD EMPTY	1123270000	B.100			



Order No.	Type	Page
-----------	------	------

## 1450000000

1454430000	RSS113024F	B.98
------------	------------	------

## 1460000000

1463520000	TIA F10	B.106
1463530000	TIA SUBD 15S	B.107
1463540000	TIAL F10	B.108
1463550000	TIAL F20	B.109

## 1470000000

1479650000	TRS 5VDC 1CO 16A	B.57
1479670000	TRS 12VDC 1CO 16A	B.57
1479680000	TRS 24VDC 1CO 16A	B.57
1479690000	TRS 24VDC 1CO 16A	B.57
1479700000	TRS 48VDC 1CO 16A	B.57
1479710000	TRS 60VDC 1CO 16A	B.57
1479730000	TRS 120VDC 1CO 16A	B.57
1479740000	TRS 230VDC 1CO 16A	B.57
1479750000	TRS 120VAC RC 1CO 16A	B.57
1479760000	TRS 230VAC RC 1CO 16A	B.57
1479780000	TRS 24VDC 1NO HC	B.60
1479780000	TRS 24VDC 1NO HC	C.16
1479810000	TRS 24VDC 1NO HCP	B.61
1479810000	TRS 24VDC 1NO HCP	C.17

## 1520000000

1520980000	ESG 9/26 SCM EOC MC NE WS	B.152
1520980000	ESG 9/26 SCM EOC MC NE WS	B.156
1527930000	Z0V 4N/2	B.196
1527930000	Z0V 4N/2	C.150
1527930000	Z0V 4N/2	C.151
1527940000	Z0V 4N/3	B.196
1527940000	Z0V 4N/3	C.150
1527940000	Z0V 4N/3	C.151
1527970000	Z0V 4N/4	B.196
1527970000	Z0V 4N/4	C.150
1527970000	Z0V 4N/4	C.151
1528040000	Z0V 4N/2 BL	B.196
1528040000	Z0V 4N/2 BL	C.150
1528040000	Z0V 4N/2 BL	C.151
1528080000	Z0V 4N/3 BL	B.196
1528080000	Z0V 4N/3 BL	C.150
1528080000	Z0V 4N/3 BL	C.151
1528090000	Z0V 4N/4 BL	B.196
1528090000	Z0V 4N/4 BL	C.150
1528090000	Z0V 4N/4 BL	C.151
1528120000	Z0V 4N/4 BL	B.196
1528120000	Z0V 4N/4 BL	C.150
1528120000	Z0V 4N/4 BL	C.151
1528230000	Z0V 4N/10 BL	B.196
1528230000	Z0V 4N/10 BL	C.150
1528230000	Z0V 4N/10 BL	C.151

## 1540000000

1542380000	DRMKIT 24VDC 2CO LD	B.145
1542370000	DRMKIT 220VDC 2CO LD	B.145
1542380000	DRMKIT 24VAC 2CO LD	B.145
1542390000	DRMKIT 230VAC 2CO LD	B.145
1542410000	DRMKIT 24VDC 4CO LD	B.149
1542420000	DRMKIT 220VDC 4CO LD	B.149
1542430000	DRMKIT 24VAC 4CO LD	B.149
1542450000	DRMKIT 230VAC 4CO LD	B.149
1542460000	DRMKIT 24VDC 2CO LD/PB	B.145
1542470000	DRMKIT 220VDC 2CO LD/PB	B.145
1542480000	DRMKIT 24VAC 2CO LD/PB	B.145
1542490000	DRMKIT 230VAC 2CO LD/PB	B.145
1542510000	DRMKIT 24VDC 4CO LD/PB	B.149
1542520000	DRMKIT 220VDC 4CO LD/PB	B.149
1542530000	DRMKIT 24VAC 4CO LD/PB	B.149
1542540000	DRMKIT 230VAC 4CO LD/PB	B.149

## 1600000000

1609900000	WS 12/6 MC NE WS	C.150
1609900000	WS 12/6 MC NE WS	C.151

## 1810000000

1818400000	WS 10/6 M MC NE WS	B.103
------------	--------------------	-------

## 1820000000

1828450000	WS 10/6 MC NE WS	B.196
------------	------------------	-------

## 1900000000

1905970000	WS 10/12 MC NE WS	B.103
------------	-------------------	-------

## 1980000000

1984090000	RSS110024	B.98
1984100000	RSS110005	B.98
1984110000	RSS110012	B.98
1984120000	RSS110060	B.98

Order No.	Type	Page
-----------	------	------

1984540000	TRS 24VDC 1CO AGSNO	B.39
1984540000	TRS 24VDC 1CO AGSNO	C.85
1984560000	TRS 12VDC 1CO CID2	B.93
1984570000	TRS 24VDC 1CO CID2	B.93
1984580000	TRS 24VDC 1CO CID2	B.93
1984590000	TRS 120VACRC 1CO CID2	B.93
1984600000	TRS 230VACRC 1CO CID2	B.93
1984610000	TRS 24-230VDC 1CO CID2	B.93
1984620000	TRS 12VDC 1COAU CID2	B.95
1984630000	TRS 24VDC 1COAU CID2	B.95
1984640000	TRS 120VACRC 1COAU CID2	B.95
1984650000	TRS 24-230VDC 1COAU CID2	B.95

## 1990000000

1990960000	TOS 24VDC 24VDC5A	B.91
------------	-------------------	------

## 2150000000

2152860000	TRS 5VDC 1CO AGSNO	B.39
2152860000	TRS 5VDC 1CO AGSNO	C.85
2152880000	TRS 12VDC 1CO AGSNO	B.39
2152880000	TRS 12VDC 1CO AGSNO	C.85
2152900000	TRS 120VAC RC 1CO AGSNO	B.39
2152900000	TRS 120VAC RC 1CO AGSNO	C.85
2152920000	TRS 230VAC RC 1CO AGSNO	B.39
2152920000	TRS 230VAC RC 1CO AGSNO	C.85
2152940000	TRS 24VDC 1CO AGSNO	B.39
2152940000	TRS 24VDC 1CO AGSNO	C.85
2153060000	TRS 48VDC 1CO AGSNO	B.39
2153060000	TRS 48VDC 1CO AGSNO	C.85
2153500000	TRS 60VDC 1CO AGSNO	B.39
2153500000	TRS 60VDC 1CO AGSNO	C.85
2153570000	TRS 120VDC 1CO AGSNO	B.39
2153570000	TRS 120VDC 1CO AGSNO	C.85
2153590000	TRS 230VDC 1CO AGSNO	B.39
2153590000	TRS 230VDC 1CO AGSNO	C.85

## 2460000000

2460450000	Z0V 4N/2 RD	B.196
2460450000	Z0V 4N/2 RD	C.150
2460450000	Z0V 4N/2 RD	C.151
2460740000	Z0V 4N/10 RD	B.196
2460740000	Z0V 4N/10 RD	C.150
2460740000	Z0V 4N/10 RD	C.151
2460800000	Z0V 4N/4 RD	B.196
2460800000	Z0V 4N/4 RD	C.150
2460800000	Z0V 4N/4 RD	C.151
2460810000	Z0V 4N/3 RD	B.196
2460810000	Z0V 4N/3 RD	C.150
2460810000	Z0V 4N/3 RD	C.151

## 2470000000

2476340000	DRIKIT 12VDC 1CO LD	B.129
2476680000	DRIKIT 24VDC 1CO LD	B.129
2476690000	DRIKIT 48VDC 1CO LD	B.129
2476700000	DRIKIT 110VDC 1CO LD	B.129
2476710000	DRIKIT 24VAC 1CO LD	B.129
2476720000	DRIKIT 115VAC 1CO LD	B.129
2476730000	DRIKIT 230VAC 1CO LD	B.129
2476740000	DRIKIT 12VDC 1CO LD/PB	B.129
2476750000	DRIKIT 24VDC 1CO LD/PB	B.129
2476760000	DRIKIT 48VDC 1CO LD/PB	B.129
2476770000	DRIKIT 110VDC 1CO LD/PB	B.129
2476780000	DRIKIT 24VAC 1CO LD/PB	B.129
2476790000	DRIKIT 115VAC 1CO LD/PB	B.129
2476800000	DRIKIT 230VAC 1CO LD/PB	B.129
2476810000	DRIKIT 12VDC 2CO LD	B.133
2476820000	DRIKIT 24VDC 2CO LD	B.133
2476830000	DRIKIT 48VDC 2CO LD	B.133
2476840000	DRIKIT 110VDC 2CO LD	B.133
2476850000	DRIKIT 24VAC 2CO LD	B.133
2476860000	DRIKIT 115VAC 2CO LD	B.133
2476870000	DRIKIT 230VAC 2CO LD	B.133
2476880000	DRIKIT 12VDC 2CO LD/PB	B.133
2476890000	DRIKIT 24VDC 2CO LD/PB	B.133
2476900000	DRIKIT 48VDC 2CO LD/PB	B.133
2476910000	DRIKIT 110VDC 2CO LD/PB	B.133
2476920000	DRIKIT 24VAC 2CO LD/PB	B.133
2476930000	DRIKIT 115VAC 2CO LD/PB	B.133
2476940000	DRIKIT 230VAC 2CO LD/PB	B.133

## 2490000000

2496190000	ITS 24-240VDC 1CO M7C	C.106
------------	-----------------------	-------

## 2500000000

2500980000	SCS 24VDC P15L30S1	C.120
------------	--------------------	-------

## 2540000000

2545120000	ITS 24-240VDC M7C PU10	C.106
------------	------------------------	-------

## 2550000000

2556350000	TCC 6.4/2 OR	B.102
------------	--------------	-------

Order No.	Type	Page
-----------	------	------

2556360000	TCC 6.4/10 OR	B.102
2556370000	TCC 6.4/51 OR	B.102
2556380000	TCC 12.8/26 OR	B.102
2556390000	TCC 6.4/2 RD	B.102
2556400000	TCC 6.4/10 RD	B.102
2556410000	TCC 6.4/51 RD	B.102
2556420000	TCC 12.8/26 RD	B.102
2556430000	TCC 6.4/2 BL	B.102
2556440000	TCC 6.4/10 BL	B.102
2556450000	TCC 6.4/51 BL	B.102
2556460000	TCC 12.8/26 BL	B.102
2556470000	TCC 6.4/2 BK	B.102
2556480000	TCC 6.4/10 BK	B.102
2556490000	TCC 6.4/51 BK	B.102
2556500000	TCC 12.8/26 BK	B.102
2558340000	ESG 6/15 SDI MC NE WS	B.136
2558340000	ESG 6/15 SDI MC NE WS	B.140

## 2570000000

2575980000	DRIKITP 115VAC 1CO LD	B.127
2575990000	DRMKITP 115VAC 2CO LD	B.143
2576000000	DRMKITP115VAC 2CO LD/PB	B.143
2576010000	DRMKITP 115VAC 4CO LD	B.147
2576020000	DRMKITP115VAC 4CO LD/PB	B.147
2576030000	DRMKITP 230VAC 2CO LD	B.143
2576040000	DRMKITP230VAC 2CO LD/PB	B.143
2576050000	DRMKITP 240VAC 4CO LD	B.147
2576060000	DRMKITP230VAC 4CO LD/PB	B.147
2576070000	DRMKITP 24VAC 2CO LD	B.143
2576080000	DRMKITP 24VAC 2CO LD/PB	B.143
2576090000	DRMKITP 24VAC 4CO LD	B.147
2576100000	DRMKITP 24VAC 4CO LD/PB	B.147
2576110000	DRMKITP 24VDC 2CO LD	B.143
2576120000	DRMKITP 24VDC 2CO LD/PB	B.143
2576130000	DRMKITP 24VDC 4CO LD	B.147
2576140000	DRMKITP 24VDC 4CO LD/PB	B.147
2576150000	DRIKITP230VAC 2CO LD/PB	B.131
2576160000	DRIKITP230VAC 1CO LD/PB	B.127
2576170000	DRIKITP115VAC 2CO LD/PB	B.131
2576180000	DRIKITP115VAC 1CO LD/PB	B.127
2576190000	DRIKITP115VAC 2CO LD/PB	B.131
2576200000	DRIKITP 24VDC 2CO LD	B.131
2576210000	DRIKITP 24VDC 1CO LD/PB	B.127
2576220000	DRIKITP 24VDC 1CO LD	B.127
2576230000	DRIKITP 24VAC 2CO LD/PB	B.131
2576240000	DRIKITP 24VAC 2CO LD	B.131
2576250000	DRIKITP 24VAC 1CO LD/PB	B.127
2576260000	DRIKITP 24VAC 1CO LD	B.127
2576270000	DRIKITP 230VAC 2CO LD	B.131
2576280000	DRIKITP 230VAC 1CO LD	B.127
2576290000	DRIKITP 115VAC 2CO LD	B.131

## 2610000000

2614820000	TRP 5VDC 1CO AGSNO	B.39
2614820000	TRP 5VDC 1CO AGSNO	C.85
2614830000	TRP 5VDC 1CO	B.33
2614830000	TRP 5VDC 1CO	C.81
2614840000	TRP 5VDC 2CO	B.63
2614840000	TRP 5VDC 2CO	C.87
2614850000	TOP 5VDC 230VAC1A	

Order No.	Type	Page
2618520000	TRP 48VUC 2C0	C.87
2618530000	TRP 24VDC 2C0 AU	B.67
2618530000	TRP 24VDC 2C0 AU	C.55
2618530000	TRP 24VDC 2C0 AU	C.89
2618540000	TRP 24VUC 2C0 AU	B.67
2618540000	TRP 24VUC 2C0 AU	C.55
2618540000	TRP 24VUC 2C0 AU	C.89
2618550000	TRP 12VDC 2C0	B.63
2618550000	TRP 12VDC 2C0	C.87
2618560000	TRP 48VUC 2C0 AU	B.67
2618560000	TRP 48VUC 2C0 AU	C.55
2618560000	TRP 48VUC 2C0 AU	C.89
2618570000	TRP 120VUC 2C0	B.63
2618570000	TRP 120VUC 2C0	C.87
2618580000	TRP 5VDC 2C0 AU	B.67
2618580000	TRP 5VDC 2C0 AU	C.55
2618580000	TRP 5VDC 2C0 AU	C.89
2618590000	TRP 120VUC 2C0 AU	B.67
2618590000	TRP 120VUC 2C0 AU	C.55
2618590000	TRP 120VUC 2C0 AU	C.89
2618600000	TOP 12VDC 48VDC0.1A	B.79
2618600000	TOP 12VDC 48VDC0.1A	C.57
2618600000	TOP 12VDC 48VDC0.1A	C.75
2618620000	TOP 230VAC RC 48VDC0.1A	B.79
2618620000	TOP 230VAC RC 48VDC0.1A	C.57
2618620000	TOP 230VAC RC 48VDC0.1A	C.75
2618640000	TOP 24VUC 48VDC0.1A	B.79
2618640000	TOP 24VUC 48VDC0.1A	C.57
2618640000	TOP 24VUC 48VDC0.1A	C.75
2618650000	TOP 120VAC RC 48VDC0.1A	B.79
2618650000	TOP 120VAC RC 48VDC0.1A	C.57
2618650000	TOP 120VAC RC 48VDC0.1A	C.75
2618660000	TOP 120VAC RC 24VDC2A	C.77
2618670000	TOP 230VAC RC 24VDC2A	B.83
2618670000	TOP 230VAC RC 24VDC2A	C.77
2618680000	TOP 120VUC 48VDC0.1A	B.79
2618680000	TOP 120VUC 48VDC0.1A	C.57
2618680000	TOP 120VUC 48VDC0.1A	C.75
2618690000	TOP 230VUC 48VDC0.1A	C.57
2618690000	TOP 230VUC 48VDC0.1A	C.75
2618700000	TOP 24VDC 24VDC3.5A	B.90
2618710000	TOP 48VUC 48VDC0.1A	B.79
2618710000	TOP 48VUC 48VDC0.1A	C.57
2618710000	TOP 48VUC 48VDC0.1A	C.75
2618720000	TOP 24VDC 24VDC2A	B.83
2618720000	TOP 24VDC 24VDC2A	C.77
2618730000	TOP 24VUC 24VDC2A	B.83
2618730000	TOP 24VUC 24VDC2A	C.77
2618740000	TOP 24VDC EMPTY	B.101
2618750000	TOP 24VDC ACT	B.85
2618750000	TOP 24VDC ACT	C.19
2618760000	TOP 48VUC 24VDC2A	B.83
2618760000	TOP 48VUC 24VDC2A	C.77
2618770000	TOP 120VUC 24VDC2A	B.83
2618770000	TOP 120VUC 24VDC2A	C.77
2618790000	TOP 24VDC 48VDC0.1A	B.79
2618790000	TOP 24VDC 48VDC0.1A	C.57
2618790000	TOP 24VDC 48VDC0.1A	C.75
2618800000	TOP 230VUC 24VDC2A	B.83
2618800000	TOP 230VUC 24VDC2A	C.77
2618810000	TOP 5VDC 24VDC2A	B.83
2618810000	TOP 5VDC 24VDC2A	C.77
2618820000	TOP 12VDC 24VDC2A	B.83
2618820000	TOP 12VDC 24VDC2A	C.77
2618830000	TOP 24VDC 24VDC5A	B.91
2618870000	TRP 24VDC 1C0 EMPTY	B.100
2618880000	TRP 120VAC RC 1C0 EMPTY	B.100
2618890000	TRP 230VAC RC 1C0 EMPTY	B.100
2618900000	TRP 60VUC 1C0 EMPTY	B.100
2618910000	TRP 24VUC 1C0 EMPTY	B.100
2618920000	TRP 48VUC 1C0 EMPTY	B.100
2618930000	TRP 12VDC 1C0 EMPTY	B.100
2618940000	TXP SUPPLY	B.102
2618950000	TRP 120VUC 1C0 EMPTY	B.100
2618960000	TRP 230VUC 1C0 EMPTY	B.100
2618970000	TOP 60VUC 24VDC2A	B.83
2618970000	TOP 60VUC 24VDC2A	C.77

## 2630000000

2633940000	SCS 24VDC P1SIL3ES LL	C.124
2634010000	SCS 24VDC P1SIL3ES LL-T	C.125
2639560000	TRS T 24VDC 1C0 M3	B.75
2639560000	TRS T 24VDC 1C0 M3	C.94
2639720000	TRS T 24VDC 1C0 M3 EMPTY	B.75
2639720000	TRS T 24VDC 1C0 M3 EMPTY	C.95
2639730000	TRP T 24VDC 1C0 M3	B.74
2639730000	TRP T 24VDC 1C0 M3	C.94
2639740000	TRP T 24VDC 1C0 M3 EMPTY	B.75
2639740000	TRP T 24VDC 1C0 M3 EMPTY	C.95

## 2660000000

2662850000	TRS 24-230VUC 1C0 ED2	B.36
2662860000	TRS 24-230VUC 1C0 AU ED2	B.37
2662860000	TRS 24-230VUC 1C0 AU ED2	C.52
2662870000	TRS 24-230VUC 1C0 EMPTY ED2	B.100

Order No.	Type	Page
2662880000	TRS 24-230VUC 2C0 ED2	B.64
2662890000	TRS 24-230VUC 2C0 AU ED2	B.68
2662890000	TRS 24-230VUC 2C0 AU ED2	C.53
2662900000	TRS 24-230VUC 2C0 EMPTY ED2	B.101
2662910000	TOS 24-230VUC 48VDC0.1A ED2	B.80
2662910000	TOS 24-230VUC 48VDC0.1A ED2	C.58
2662920000	TOS 24-230VUC 24VDC2A ED2	B.84
2662930000	TOS 24-230VUC 230VAC1A ED2	B.88
2662940000	TOS 24-230VUC 24VDC3.5A ED2	B.90
2662950000	TOS 24-230VUC EMPTY ED2	B.101
2662960000	TRS 24-230VUC 1C0 16A ED2	B.58
2662970000	TRS 24-230VUC 1NO HC ED2	C.60
2662970000	TRS 24-230VUC 1NO HC ED2	B.152
2662980000	TRS 24-230VUC 1NO HCP ED2	B.61
2662980000	TRS 24-230VUC 1NO HCP ED2	C.17
2662990000	TOS 24-230VUC 24VDC5A ED2	B.91
2663000000	TRS 24-230VUC 1C0 AGSNO ED2	B.80
2663010000	TRP 24-230VUC 1C0 ED2	B.36
2663020000	TRP 24-230VUC 1C0 AU ED2	B.37
2663020000	TRP 24-230VUC 1C0 AU ED2	C.52
2663030000	TRP 24-230VUC 1C0 EMPTY ED2	B.100
2663040000	TRP 24-230VUC 2C0 ED2	B.64
2663050000	TRP 24-230VUC 2C0 AU ED2	B.68
2663050000	TRP 24-230VUC 2C0 AU ED2	C.53
2663060000	TRP 24-230VUC 2C0 EMPTY ED2	B.101
2663070000	TRP 24-230VUC 48VDC0.1A ED2	B.80
2663070000	TRP 24-230VUC 48VDC0.1A ED2	C.58
2663080000	TOP 24-230VUC 24VDC2A ED2	B.84
2663090000	TOP 24-230VUC 230VAC1A ED2	B.88
2663100000	TOP 24-230VUC 24VDC3.5A ED2	B.90
2663110000	TOP 24-230VUC EMPTY ED2	B.101
2663120000	TRP 24-230VUC 1C0 16A ED2	B.58
2663130000	TRP 24-230VUC 1NO HC ED2	B.60
2663130000	TRP 24-230VUC 1NO HC ED2	C.16
2663140000	TRP 24-230VUC 1NO HCP ED2	B.61
2663140000	TRP 24-230VUC 1NO HCP ED2	C.17
2663150000	TOP 24-230VUC 24VDC5A ED2	B.91
2663160000	TRP 24-230VUC 1C0 AGSNO ED2	B.40

## 2680000000

2680850000	TRP 5VDC 2C0 EMPTY	B.101
2680860000	TRP 12VDC 2C0 EMPTY	B.101
2680870000	TRP 24VDC 2C0 EMPTY	B.101
2680880000	TRP 24VDC 2C0 EMPTY	B.101
2680890000	TRP 48VUC 2C0 EMPTY	B.101
2681000000	TRP 60VUC 2C0 EMPTY	B.101
2681010000	TRP 120VUC 2C0 EMPTY	B.101
2681020000	TRP 230VUC 2C0 EMPTY	B.101
2681030000	TRP 120VAC RC 2C0 EMPTY	B.101
2681190000	TRP 230VAC RC 2C0 EMPTY	B.101

## 2690000000

2697250000	TFIS 12-240VUC 1C0 M7C	C.98
2697260000	TFIS 12-240VUC 1C0 CG	C.99
2697270000	TFIS 12-240VUC 2NO SD	C.102
2697280000	TFIS 24-240VUC 1C0 ON	C.100
2697290000	TFIS 24-240VUC 1C0 OFFC	C.101

## 2700000000

2706290000	TRS 24VUC 2C0 FG	B.77
2706290000	TRS 24VUC 2C0 FG	C.135
2706430000	TRP 24VUC 2C0 FG	B.77
2706430000	TRP 24VUC 2C0 FG	C.135

## 2720000000

2723360000	RCH424024FG	B.77
2723360000	RCH424024FG	C.135

## 2740000000

2749260000	SDS 0.4X2.0X60	B.103
2749320000	SDS 0.4X2.5X75	B.136
2749320000	SDS 0.4X2.5X75	B.140
2749340000	SDS 0.6X3.5X100	B.103
2749340000	SDS 0.6X3.5X100	B.196
2749340000	SDS 0.6X3.5X100	C.145
2749340000	SDS 0.6X3.5X100	C.150
2749340000	SDS 0.6X3.5X100	C.151
2749410000	SDK PH1 X 80	B.136
2749410000	SDK PH1 X 80	B.137
2749410000	SDK PH1 X 80	B.141
2749410000	SDK PH1 X 80	B.157
2749410000	SDK PH1 X 80	B.162
2749420000	SDK PH2 X 100	B.172
2749420000	SDK PH2 X 100	B.173
2749420000	SDK PH2 X 100	B.182
2749420000	SDK PH2 X 100	C.29
2749420000	SDK PH2 X 100	C.38
2749450000	SDK PZ2 X 100	C.145
2749650000	SDIK SLIM PH1 X 80	B.157
2749650000	SDIK SLIM PH1 X 80	B.162
2749660000	SDIK SLIM PH2 X 100	B.172
2749660000	SDIK SLIM PH2 X 100	B.173

Order No.	Type	Page
2749660000	SDIK SLIM PH2 X 100	B.182
2749660000	SDIK SLIM PH2 X 100	C.28
2749660000	SDIK SLIM PH2 X 100	C.29
2749660000	SDIK SLIM PH2 X 100	C.38
2749780000	SDIS 0.4X2.0X60	B.103
2749790000	SDIS 0.4X2.5X75	B.136
2749790000	SDIS 0.4X2.5X75	B.140
2749810000	SDIS 0.6X3.5X100	B.103
2749890000	SDIK PH1 X 80	B.136
2749890000	SDIK PH1 X 80	B.137
2749890000	SDIK PH1 X 80	B.140
2749890000	SDIK PH1 X 80	B.141
2749890000	SDIK PH1 X 80	B.152
2749890000	SDIK PH1 X 80	B.153
2749890000	SDIK PH1 X 80	B.156
2749890000	SDIK PH1 X 80	B.157
2749890000	SDIK PH1 X 80	B.162
2749900000	SDIK PH2 X 100	B.172
2749900000	SDIK PH2 X 100	B.173
2749900000	SDIK PH2 X 100	B.182
2749900000	SDIK PH2 X 100	C.28
2749900000	SDIK PH2 X 100	C.29
2749900000	SDIK PH2 X 100	C.38

## 2750000000

2759070000	FSKIT 24VDC 3NO 1NC FG LD AGSNO AU	C.129
2759080000	FSKIT 24VDC 2NO 2NC FG LD AGSNO AU	C.129
2759090000	FSKIT 24VDC 4NO 2NC FG LD AGSNO AU	C.131
2759100000	FSKIT 24VDC 3NO 3NC FG LD AGSNO AU	C.131

## 2760000000

2765010000	DRR273012L	B.159
2765020000	DRR273024L	B.159
2765030000	DRR273048L	B.159
2765040000	DRR273110L	B.159
2765050000	DRR273220L	B.159
2765060000	DRR373012L	B.161
2765070000	DRR373024L	B.161
2765080000	DRR373048L	B.161
2765090000	DRR373110L	B.161
2765100000	DRL173012L	B.165
2765100000	DRL173012L	C.21
2765110000	DRL173024L	B.165
2765110000	DRL173024L	C.21
2765120000	DRL173048L	B.165
2765120000	DRL173048L	C.21
2765130000	DRL173110L	B.165
2765130000	DRL173110L	C.21
2765140000	DRL173220L	B.165
2765140000	DRL173220L	C.21
2765150000	DRL273012L	B.167
2765150000	DRL273012L	C.23
2765160000	DRL273024L	B.167
2765160000	DRL273024L	C.23
2765170000	DRL273048L	B.167
2765170000	DRL273048L	C.23
2765180000	DRL273110L	B.167
2765180000	DRL273110L	C.23
2765190000	DRL273220L	B.167
2765190000	DRL273220L	C.23
2765200000	DRR373220L	B.161
2765210000	DRL373012L	B.169
2765210000	DRL373012L	C.25
2765220000	DRL373024L	B.169
2765220000	DRL373024L	C.25
2765230000	DRL373048L	B.169
2765230000	DRL373048L	C.25
2765240000	DRL373110L	B.169
2765240000	DRL373110L	C.25
2765250000	DRL373220L	B.169
2765250000	DRL373220L	C.25
2765260000	DRL573012L	B.171
2765260000	DRL573012L	C.27
2765270000	DRL573024L	B.171
2765270000	DRL5	

Order No.	Type	Page
2810870000	ZDV 4N/20 BK	C.150
2810870000	ZDV 4N/20 BK	C.151
2810880000	ZDV 4N/3 BK	B.196
2810880000	ZDV 4N/3 BK	C.150
2810880000	ZDV 4N/3 BK	C.151
2810890000	ZDV 4N/4 BK	B.196
2810890000	ZDV 4N/4 BK	C.150
2810890000	ZDV 4N/4 BK	C.151

## 2850000000

2851620000	RSS111024T	B.98
2851640000	RSS113024Y	B.98
2855800000	TRP 24VDC 1CD AGSNO PB	B.43
2855810000	TRP 24VDC 1CD AGSNO PB	B.43
2855820000	TRP 24VDC 1CD AGSNO AU PB	B.47
2855830000	TRP 24VDC 1CD AGSNO AU PB	B.47
2855840000	TRP 24VDC ACT PB	B.54
2855840000	TRP 24VDC ACT PB	C.18
2855850000	TRS 24VDC ACT PB	B.54
2855850000	TRS 24VDC ACT PB	C.18
2855860000	TRS 24VDC 1CD AGSNO AU PB	B.47
2855870000	TRS 24VDC 1CD AGSNO PB	B.43
2855880000	TRS 24VDC 1CD AGSNO AU PB	B.47
2855890000	TRS 24VDC 1CD AGSNO PB	B.43
2855900000	TRP 24-230VDC 1CD AGSNO AU ED2 PB	B.48
2855910000	TRP 24-230VDC 1CD AGSNO ED2 PB	B.44
2855920000	TRS 24-230VDC 1CD AGSNO AU ED2 PB	B.48
2855930000	TRS 24-230VDC 1CD AGSNO ED2 PB	B.44

## 2860000000

2860020000	FSKIT 24VDC 5NO1NC FG LD AGSNO AU	C.131
------------	-----------------------------------	-------

## 2880000000

2883800000	ZDV 4N/20	B.196
2883800000	ZDV 4N/20	C.150
2883800000	ZDV 4N/20	C.151

## 2890000000

2898310000	TFIP 12-240VDC 1CD C6	C.99
2898320000	TFIP 12-240VDC 1CD M7C	C.98
2898330000	TFIP 24-240VDC 1CD OFFC	C.101
2898340000	TFIP 24-240VDC 1CD ON	C.100

## 2980000000

2986890000	PSSRN K 24VDC 1Z K 240VAC 20A	C.140
2986900000	PSSRN K 24VDC 1Z K 600VAC 30A	C.141
2986910000	PSSRN K 24VDC 3Z K 600VAC 20A	C.144
2986920000	PSSRN S 24VDC 1M K 600VAC 30A T	C.142
2986930000	PSSRN K 24VDC 1D K 100VDC 15A	C.143
2988280000	TRP 24VDC 1CD 16A PB	B.51
2988300000	TRP 24VDC 1CD 16A PB	B.51
2988310000	TRP 120VDC 1CD 16A PB	B.51
2988320000	TRP 230VDC 1CD 16A PB	B.51
2988330000	TRP 24-230VDC 1CD 16A ED2 PB	B.52
2988340000	TRP 24VDC 2CD PB	B.71
2988350000	TRP 24VDC 2CD PB	B.71
2988360000	TRP 120VDC 2CD PB	B.71
2988370000	TRP 230VDC 2CD PB	B.71
2988380000	TRP 24-230VDC 2CD ED2 PB	B.72
2988390000	TRS 24VDC 1CD 16A PB	B.51
2988400000	TRS 24VDC 1CD 16A PB	B.51
2988410000	TRS 120VDC 1CD 16A PB	B.51
2988420000	TRS 230VDC 1CD 16A PB	B.51
2988430000	TRS 24-230VDC 1CD 16A ED2 PB	B.52
2988440000	TRS 24VDC 2CD PB	B.71
2988450000	TRS 24VDC 2CD PB	B.71
2988460000	TRS 120VDC 2CD PB	B.71
2988470000	TRS 230VDC 2CD PB	B.71
2988480000	TRS 24-230VDC 2CD ED2 PB	B.72

## 3050000000

3052280000	CRH10012	B.113
3052290000	CRH10024	B.113
3052300000	CRH10048	B.113
3052310000	CRH10110	B.113
3052320000	CRH10524	B.113
3052330000	CRH10615	B.113
3052340000	CRH10730	B.113
3052350000	CRH10012T	B.113
3052360000	CRH10024T	B.113
3052370000	CRH10048T	B.113
3052380000	CRH10110T	B.113
3052390000	CRH10524T	B.113
3052400000	CRH10615T	B.113
3052410000	CRH10730T	B.113
3052420000	CRH20012	B.115
3052430000	CRH20024	B.115
3052440000	CRH20048	B.115
3052450000	CRH20110	B.115
3052460000	CRH20524	B.115
3052470000	CRH20615	B.115
3052490000	CRH20730	B.115
3052500000	CRH20012T	B.115

Order No.	Type	Page
3052510000	CRH20024T	B.115
3052520000	CRH20048T	B.115
3052530000	CRH20110T	B.115
3052540000	CRH20524T	B.115
3052550000	CRH20615T	B.115
3052560000	CRH20730T	B.115
3052570000	CSI P 2CD	B.116
3052590000	CSI S 2CD	B.116
3052620000	CXI CCS 8PGY	B.116
3052630000	CXI CLIP LM	B.116
3052640000	CXI CLIP HM	B.116
3052650000	CXI CCP 2P RD	B.116
3052660000	CXI CCP 2P BL	B.116
3052690000	CXI CCP 8P RD	B.116
3052700000	CXI CCP 8P BL	B.116
3052710000	CXI CLIP P	B.116
3052720000	CRM20012	B.119
3052730000	CRM20024	B.119
3052740000	CRM20048	B.119
3052750000	CRM20110	B.119
3052760000	CRM20524	B.119
3052770000	CRM20615	B.119
3052780000	CRM20730	B.119
3052790000	CRM20012T	B.119
3052800000	CRM20024T	B.119
3052810000	CRM20048T	B.119
3052820000	CRM20110T	B.119
3052830000	CRM20524T	B.119
3052840000	CRM20615T	B.119
3052850000	CRM20730T	B.119
3052860000	CRM20012TLD	B.119
3052870000	CRM20024TLD	B.119
3052880000	CRM20048TLD	B.119
3052890000	CRM20110TLD	B.119
3052900000	CRM20524TLD	B.119
3052910000	CRM20615TLD	B.119
3052920000	CRM20730TLD	B.119
3052930000	CRM40012	B.121
3052940000	CRM40024	B.121
3052950000	CRM40048	B.121
3052960000	CRM40110	B.121
3052970000	CRM40524	B.121
3052980000	CRM40615	B.121
3052990000	CRM40730	B.121
3053000000	CRM40012T	B.121
3053010000	CRM40024T	B.121
3053020000	CRM40048T	B.121
3053030000	CRM40110T	B.121
3053040000	CRM40524T	B.121
3053050000	CRM40615T	B.121
3053060000	CRM40730T	B.121
3053070000	CRM40012TLD	B.121
3053080000	CRM40024TLD	B.121
3053090000	CRM40048TLD	B.121
3053100000	CRM40110TLD	B.121
3053110000	CRM40524TLD	B.121
3053120000	CRM40615TLD	B.121
3053130000	CRM40730TLD	B.121
3053140000	CSM P 4CD	B.122
3053160000	CSM S 4CD	B.122
3053180000	CXM CCS 8P GY	B.122
3053190000	CXM CLIP M	B.122
3053200000	CXM CCP 8P RD	B.122
3053210000	CXM CCP 2P RD	B.122
3053230000	CXM CCP 2P BL	B.122
3053240000	CXM CLIP P	B.122
3053250000	CXX JMP 2P RD	B.122
3053260000	CXX JMP 2P BL	B.122
3053270000	CXX D 21N	B.122
3053290000	CXX LD 41R	B.122
3053310000	CXX LD 41G	B.122
3053320000	CXX LD 42R	B.122
3053340000	CXX LD 42G	B.122
3053370000	CXX RC 51	B.122
3053390000	CXX RC 52	B.122
3053400000	CXX RC 53	B.122
3053410000	CXX L 61R	B.122
3053420000	CXX L 61G	B.122
3053440000	CXX L 62G	B.122
3053470000	CXX V 71	B.122
3053480000	CXX V 72	B.122
3053490000	CXX V 73	B.122

## 4050000000

4058560000	RCL424012	B.98
4058570000	RCL424024	B.98
4058580000	RCL425024	B.98
4058590000	RCL424110	B.98
4058750000	RCL424048	B.98
4058760000	RCL424060	B.98

## 4060000000

4060120000	RSS113024	B.98
4061180000	SSS RELAIS 24V/24V 0,1ADC	B.99
4061190000	SSS RELAIS 24V/24V 2ADC	B.99
4061200000	SSS RELAIS 60V/24V 2ADC	B.99
4061210000	SSS RELAIS 24V/230V 1AAC	B.99

Order No.	Type	Page
4061220000	SSS RELAIS 60V/230V 1AAC	B.99
4061230000	SSS RELAIS 60V/24V 0,1ADC	B.99
4061580000	RSS113005	B.98
4061590000	RSS112024	B.98
4061600000	RSS112060	B.98
4061610000	RSS113012	B.98
4061630000	RSS113060	B.98
4064310000	SSS RELAIS 5V/24V 2ADC	B.99
4064320000	SSS RELAIS 5V/24V 0,1ADC	B.99

## 4070000000

4074580000	RCL425012	B.98
------------	-----------	------

## 7760000000

7760056014	RIM 3 110/230VAC	B.136
7760056014	RIM 3 110/230VAC	B.140
7760056014	RIM 3 110/230VAC	B.152
7760056014	RIM 3 110/230VAC	B.156
7760056014	RIM 3 110/230VAC	B.157
7760056014	RIM 3 110/230VAC	B.172
7760056014	RIM 3 110/230VAC	C.28
7760056015	RIM 2 6/24VDC	B.136
7760056015	RIM 2 6/24VDC	B.140
7760056015	RIM 2 6/24VDC	B.152
7760056015	RIM 2 6/24VDC	B.156
7760056015	RIM 2 6/24VDC	B.157
7760056015	RIM 2 6/24VDC	B.172
7760056015	RIM 2 6/24VDC	C.28
7760056016	RIM 2 24/60VDC	B.136
7760056016	RIM 2 24/60VDC	B.140
7760056016	RIM 2 24/60VDC	B.152
7760056016	RIM 2 24/60VDC	B.156
7760056016	RIM 2 24/60VDC	B.157
7760056016	RIM 2 24/60VDC	B.172
7760056016	RIM 2 24/60VDC	C.28
7760056017	RIM 2 110/230VDC	B.136
7760056017	RIM 2 110/230VDC	B.140
7760056017	RIM 2 110/230VDC	B.152
7760056017	RIM 2 110/230VDC	B.156
7760056017	RIM 2 110/230VDC	B.157
7760056017	RIM 2 110/230VDC	B.172
7760056017	RIM 2 110/230VDC	C.28
7760056018	RIM 3 24/60VDC	B.136
7760056018	RIM 3 24/60VDC	B.140
7760056018	RIM 3 24/60VDC	B.152
7760056018	RIM 3 24/60VDC	B.156
7760056018	RIM 3 24/60VDC	B.157
7760056018	RIM 3 24/60VDC	B.172
7760056018	RIM 3 24/60VDC	C.28
7760056045	RIM 3 110/230VAC LED	B.136
7760056045	RIM 3 110/230VAC LED	B.140
7760056045	RIM 3 110/230VAC LED	B.152
7760056045	RIM 3 110/230VAC LED	B.156
7760056045	RIM 3 110/230VAC LED	B.157
7760056045	RIM 3 110/230VAC LED	B.172
7760056045	RIM 3 110/230VAC LED	C.28
7760056050	DRM270012	B.151
7760056051	DRM270024	B.151
7760056052	DRM270048	B.151
7760056053	DRM270110	B.151
7760056054	DRM270220	B.151
7760056055	DRM270524	B.151
7760056056	DRM270548	B.151
7760056057	DRM270615	B.151
7760056058	DRM270730	B.151
7760056059	DRM270012L	B.151
7760056060	DRM270024L	B.151
7760056061	DRM270048L	B.151
7760056062	DRM270110L	B.151
7760056063	DRM270220L	B.151
7760056064	DRM270524L	B.151
7760056065	DRM270548L	B.151
7760056066	DRM270615L	B.151
7760056067	DRM270730L	B.151
7760056068	DRM270012LT	B.151
7760056069	DRM270024LT	B.151
7760056070	DRM270048LT	B.151
7760056071	DRM270110LT	B.151
7760056072	DRM270220LT	B.151
7760056073	DRM270524LT	B.151
7760056074	DRM270548LT	B.151
7760056075	DRM270615LT	B.151
7760056076	DRM270730LT	B.151
7760056077	DRM270024LD	B.151
7760056078	DRM570012	B.155
7760056079	DRM570024	B.155
7760056080	DRM570048	B.155
776005608		

Order No.	Type	Page
7760056351	SDI 2CD	B.140
7760056352	SDI CLIP	B.136
7760056352	SDI CLIP	B.140
7760056362	SCM 2CD P	B.152
7760056363	SCM 4CD P	B.156
7760056364	SDI 1CD P	B.136
7760056365	SDI 2CD P	B.140
7760056366	SCM/SDI P CC	B.136
7760056366	SCM/SDI P CC	B.140
7760056366	SCM/SDI P CC	B.152
7760056366	SCM/SDI P CC	B.156
7760056367	SCM CLIP P	B.152
7760056367	SCM CLIP P	B.156
7760056368	SDI CLIP LM	B.136
7760056368	SDI CLIP LM	B.140
7760056389	SDI CLIP P	B.136
7760056389	SDI CLIP P	B.140
7760056390	SDI CLIP HM	B.136
7760056390	SDI CLIP HM	B.140

## 7940000000

7940018455	RIM 3 110/230VUC	B.136
7940018455	RIM 3 110/230VUC	B.140
7940018455	RIM 3 110/230VUC	B.152
7940018455	RIM 3 110/230VUC	B.156
7940018455	RIM 3 110/230VUC	B.157
7940018455	RIM 3 110/230VUC	B.172
7940018455	RIM 3 110/230VUC	C.28
7940018457	RIM 3 6/24VUC	B.136
7940018457	RIM 3 6/24VUC	B.140
7940018457	RIM 3 6/24VUC	B.152
7940018457	RIM 3 6/24VUC	B.156
7940018457	RIM 3 6/24VUC	B.157
7940018457	RIM 3 6/24VUC	B.172
7940018457	RIM 3 6/24VUC	C.28

## 8230000000

8237710000	MCZ R 230VAC	B.187
------------	--------------	-------

## 8280000000

8286410000	MCZ TO 24VDC/150MS	C.110
8287730000	MCZ O 24VUC	B.192

## 8320000000

8324590000	MCZ TO 24VDC/50MS	C.110
8324610000	MCZ O 24VDC	B.194

## 8360000000

8365940000	MCZ O 24VUC	B.192
8365980000	MCZ R 24VDC	B.187

## 8380000000

8389030000	AP MCZ1.5 1674	B.196
------------	----------------	-------

## 8390000000

8390590000	MCZ R 24VUC	B.187
8398940000	MCZ O 5VTTL	B.194

## 8420000000

8420880000	MCZ R 120VAC	B.187
8421060000	MCZ O 120VUC	B.193
8421380000	MCZ O 230VAC	B.193

## 8440000000

8442960000	MCZ R 24VDC 5UAU	B.187
------------	------------------	-------

## 8460000000

8467470000	MCZ R 110VDC	B.187
------------	--------------	-------

## 8490000000

8495550000	MCZ R 24VDC 1NO TRAK	B.189
------------	----------------------	-------

## 8570000000

8574070000	MCZ R 48...110VDC 1NO TRAK	B.189
------------	----------------------------	-------

## 8690000000

8693790000	RCL424005	B.98
------------	-----------	------

## 8710000000

8713890000	MCZ R 24VDC 1CO TRAK	B.189
8713900000	MCZ R 36VDC 1CO TRAK	B.189
8713910000	MCZ R 48...110VDC 1CO TRAK	B.189

Order No.	Type	Page
-----------	------	------

## 8790000000

8790500000	MCZ R 48...110VDC 1CO AU TRAK	B.191
8790510000	MCZ R 36VDC 1CO AU TRAK	B.191
8790520000	MCZ R 24VDC 1CO AU TRAK	B.191

## 8820000000

8820710000	MCZ O TRAK 24.110VDC	B.195
8828370000	RCL425110	B.98

## 8930000000

8937830000	MOS 24VDC/12-300VDC 1A	C.11
8937920000	MOS 5VTTL/24VDC 0,1A	C.63
8937920000	MOS 5VTTL/24VDC 0,1A	C.71
8937930000	MOS 12-28VDC/5VTTL	C.64
8937930000	MOS 12-28VDC/5VTTL	C.72
8937940000	MOS 24VDC/5-33VDC 10A	C.10
8937970000	MOS 24VDC/8-30VDC 2A	C.12
8937980000	MOS 24VDC/5-8VDC 0,5A	C.70
8937990000	MOS 12-28VDC 100KHZ	C.62

## 8950000000

8950700000	TDS 5VDC/48VDC 0,1A	C.43
8950710000	TDS 12VDC/48VDC 0,1A	C.43
8950720000	TDS 24VDC/48VDC 0,1A	C.43
8950730000	TDS 48-60VDC/48VDC 0,1A	C.43
8950740000	TDS 110VDC/48VDC 0,1A	C.43
8950750000	TDS 220VDC/48VDC 0,1A	C.43
8950760000	TOP 5VDC/48VDC 0,1A	C.43
8950770000	TOP 12VDC/48VDC 0,1A	C.43
8950780000	TOP 24VDC/48VDC 0,1A	C.43
8950790000	TOP 48-60VDC/48VDC 0,1A	C.43
8950800000	TOP 110VDC/48VDC 0,1A	C.43
8950810000	TOP 220VDC/48VDC 0,1A	C.43
8950820000	TDS 24VAC/48VDC 0,1A	C.43
8950830000	TDS 48-60VAC/48VDC 0,1A	C.43
8950840000	TDS 120VAC/48VDC 0,1A	C.43
8950850000	TDS 230VAC/48VDC 0,1A	C.43
8950860000	TOP 24VAC/48VDC 0,1A	C.43
8950870000	TOP 48-60VAC/48VDC 0,1A	C.43
8950880000	TOP 120VAC/48VDC 0,1A	C.43
8950890000	TOP 230VAC/48VDC 0,1A	C.43
8950900000	TDS 5VDC/48VDC 0,5A	C.45
8950910000	TDS 12VDC/48VDC 0,5A	C.45
8950920000	TDS 24VDC/48VDC 0,5A	C.45
8950930000	TDS 48-60VDC/48VDC 0,5A	C.45
8950940000	TDS 110VDC/48VDC 0,5A	C.45
8950950000	TDS 220VDC/48VDC 0,5A	C.45
8950960000	TOP 5VDC/48VDC 0,5A	C.45
8950970000	TOP 12VDC/48VDC 0,5A	C.45
8950980000	TOP 24VDC/48VDC 0,5A	C.45
8950990000	TOP 48-60VDC/48VDC 0,5A	C.45
8951000000	TOP 110VDC/48VDC 0,5A	C.45
8951010000	TOP 220VDC/48VDC 0,5A	C.45
8951020000	TDS 24VAC/48VDC 0,5A	C.45
8951030000	TDS 48-60VAC/48VDC 0,5A	C.45
8951040000	TDS 120VAC/48VDC 0,5A	C.45
8951050000	TDS 230VAC/48VDC 0,5A	C.45
8951060000	TOP 24VAC/48VDC 0,5A	C.45
8951070000	TOP 48-60VAC/48VDC 0,5A	C.45
8951080000	TOP 120VAC/48VDC 0,5A	C.45
8951090000	TOP 230VAC/48VDC 0,5A	C.45
8951100000	TDS 5VDC/230VAC 0,1A	C.47
8951100000	TDS 5VDC/230VAC 0,1A	C.67
8951110000	TDS 12VDC/230VAC 0,1A	C.47
8951110000	TDS 12VDC/230VAC 0,1A	C.67
8951120000	TDS 24VDC/230VAC 0,1A	C.47
8951120000	TDS 24VDC/230VAC 0,1A	C.67
8951130000	TDS 48-60VDC/230VAC 0,1A	C.47
8951140000	TDS 110VDC/230VAC 0,1A	C.47
8951150000	TDS 220VDC/230VAC 0,1A	C.47
8951160000	TOP 5VDC/230VAC 0,1A	C.47
8951160000	TOP 5VDC/230VAC 0,1A	C.67
8951170000	TOP 12VDC/230VAC 0,1A	C.47
8951170000	TOP 12VDC/230VAC 0,1A	C.67
8951180000	TOP 24VDC/230VAC 0,1A	C.47
8951180000	TOP 24VDC/230VAC 0,1A	C.67
8951190000	TOP 48-60VDC/230VAC 0,1A	C.47
8951200000	TOP 110VDC/230VAC 0,1A	C.47
8951210000	TOP 220VDC/230VAC 0,1A	C.47
8951220000	TDS 24VAC/230VAC 0,1A	C.47
8951230000	TDS 48-60VAC/230VAC 0,1A	C.47
8951240000	TDS 120VAC/230VAC 0,1A	C.47
8951250000	TDS 230VAC/230VAC 0,1A	C.47
8951260000	TOP 24VAC/230VAC 0,1A	C.47
8951270000	TOP 48-60VAC/230VAC 0,1A	C.47
8951280000	TOP 120VAC/230VAC 0,1A	C.47
8951290000	TOP 230VAC/230VAC 0,1A	C.47

## 8970000000

8973450000	MOS FEED THROUGH	C.151
8973460000	MOS SUPPLY	C.151

Order No.	Type	Page
-----------	------	------

## 9000000000

9008370000	SDIS 0.4X2.5X75	B.152
9008370000	SDIS 0.4X2.5X75	B.156
9009030000	SDS 0.4X2.5X75	B.152
9009030000	SDS 0.4X2.5X75	B.156



# Addresses worldwide

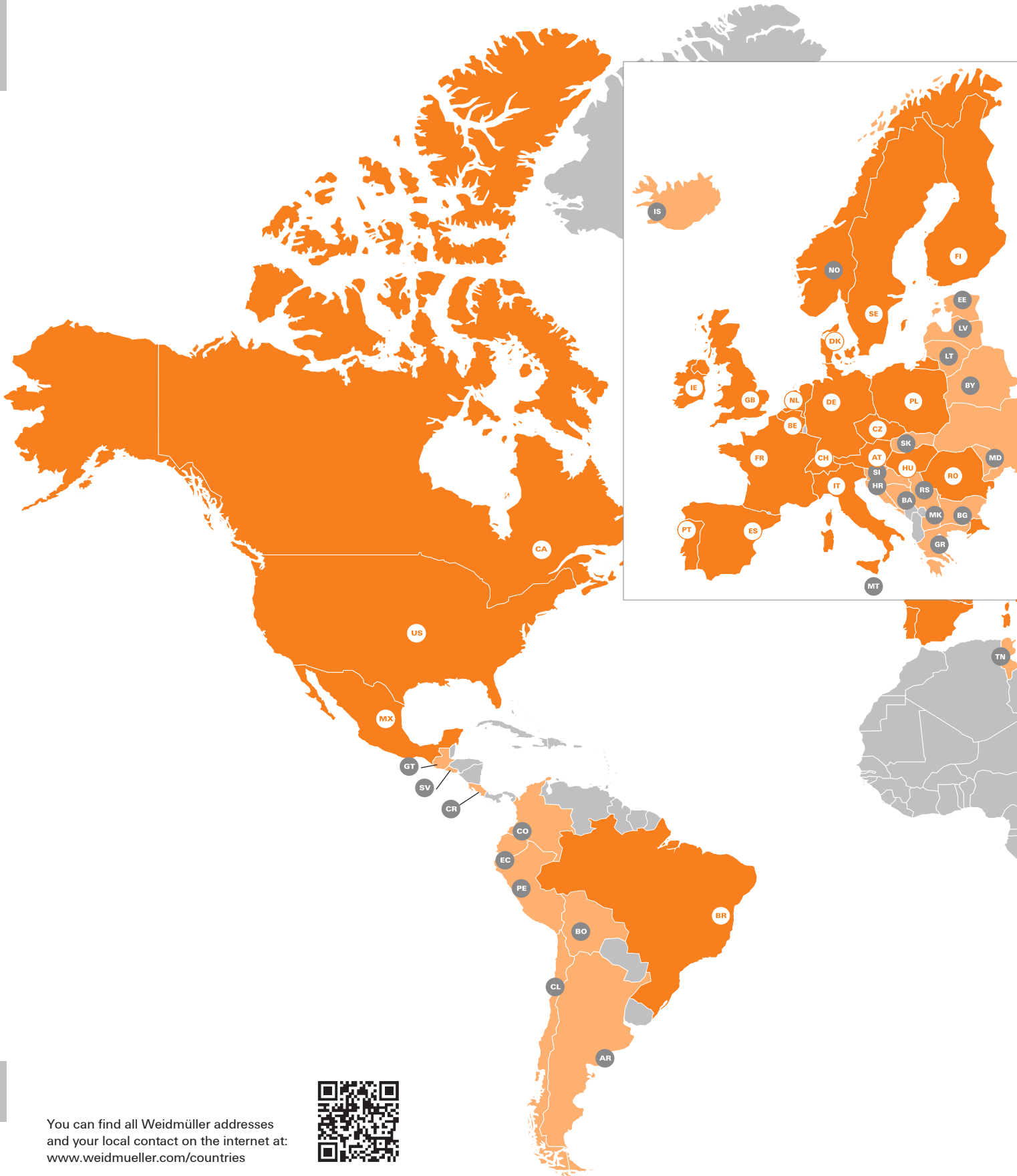

X

You can find all Weidmüller addresses and your local contact on the internet at: [www.weidmueller.com/countries](http://www.weidmueller.com/countries)



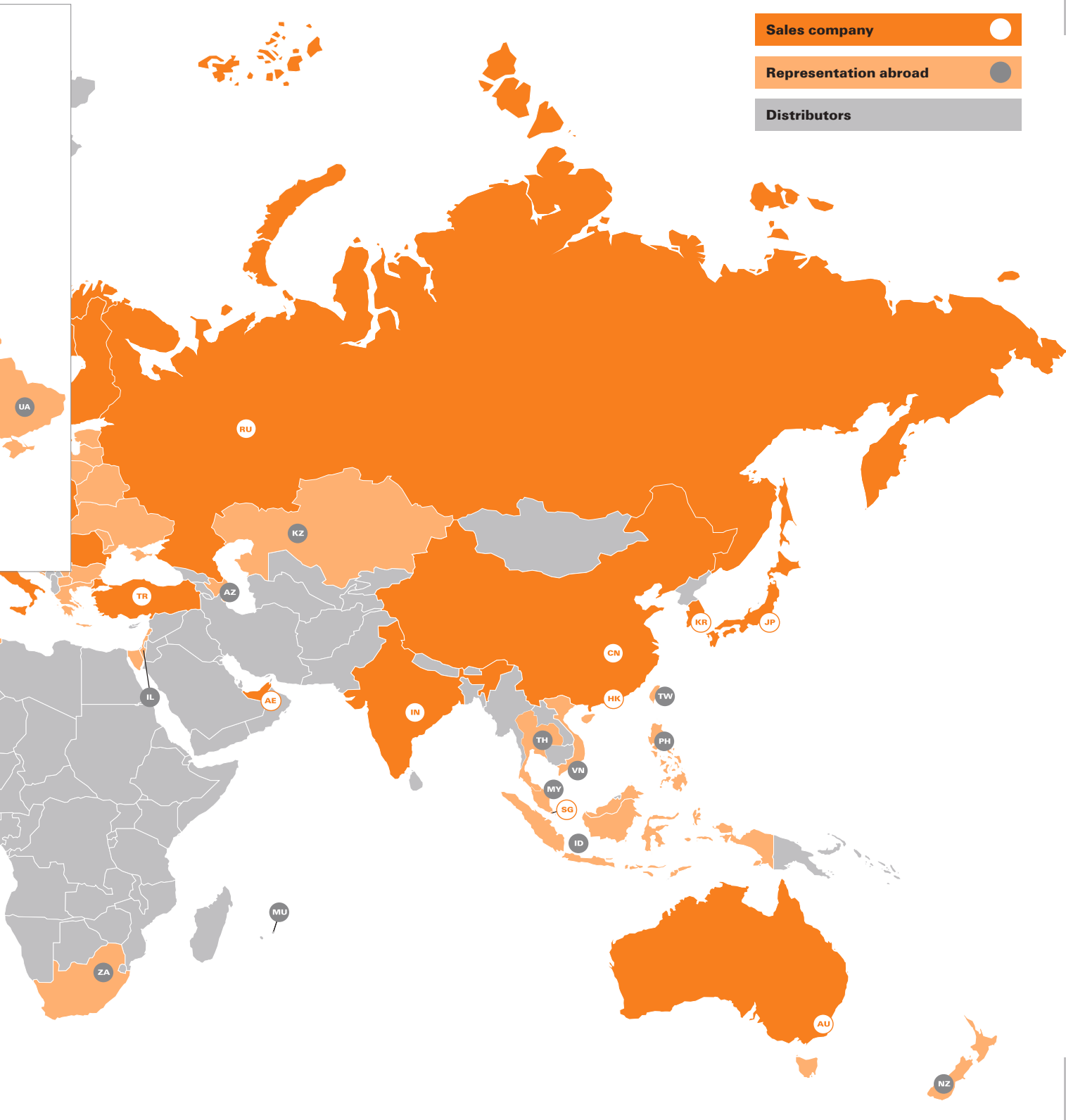

We cannot guarantee that there are no mistakes in the publications or software provided by us to the customer for the purpose of making orders. We try our best to quickly correct errors in our printed media.

All orders are based on our general terms of delivery, which can be reviewed on the websites of our group companies where you place your order. On demand we can also send the general terms of delivery to you.

---

**Imprint:** Weidmüller Interface GmbH & Co. KG, Klingenbergstraße 26, 32756 Detmold, Tel.: +49 5231 14280, E-Mail: [weidmueller@weidmueller.de](mailto:weidmueller@weidmueller.de), [www.weidmueller.de](http://www.weidmueller.de) | Limited partnership (KG), Registered office: Detmold, Register court Lemgo HRA 2790 | General partner: Weidmüller Führungsgesellschaft mbH, Registered office: Detmold, Register court Lemgo HRB 3924, VAT ID no.: DE124599660 | Corporate Executive Management: Dr. Timo Berger, Dr. Sebastian Durst, André Sombecki



## Weidmüller – Your partner in Smart Industrial Connectivity

As experienced experts we support our customers and partners around the world with products, solutions and services in the industrial environment of power, signal and data. We are at home in their industries and markets and know the technological challenges of tomorrow. We are therefore continuously developing innovative, sustainable and useful solutions for their individual needs. Together we set standards in Smart Industrial Connectivity.

Weidmüller Interface GmbH & Co. KG  
Klingenbergstraße 26  
32758 Detmold, Germany  
T +49 5231 14-0  
F +49 5231 14-292083  
[www.weidmueller.com](http://www.weidmueller.com)

Personal support can  
be found on our website:  
[www.weidmueller.com/contact](http://www.weidmueller.com/contact)

Made in Germany



Order number: 3043770000/12/2024/SMD